

REVISION HISTORY			
REV	DESCRIPTION	DATE	APPROVED

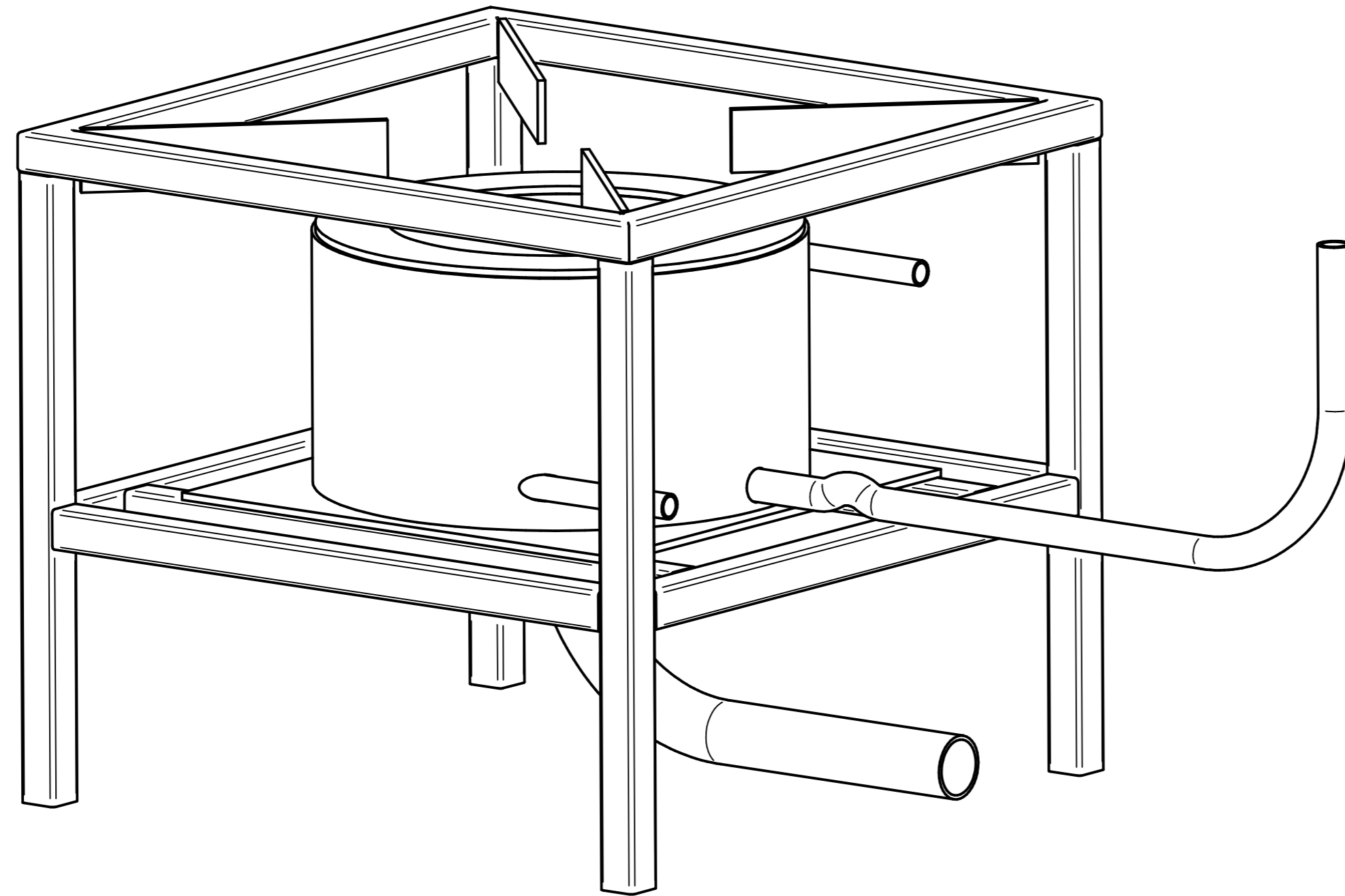

Item Number	Title	Document Number	Quantity
1*	Base Plate	210 x 210 x 3	1
2*	Burner Top	Dia 190 x 134 x 3	1
3*	Pot Support	25 x 3 x 120	4
4*	Oil Pipe	Dia 13 x ???	1
5*	Burner Inner Tube	Dia 139.5 x 3 x 100	1
6*	Burner Outer Tube	Dia 193 x 3 x 100	1
7*	Burner Pipe	Dia 25 x 16 x 300	1
8*	Water Heater Pipe	Dia 9.6 x 2000	1
9*	Top Frame	16 x 16 x 1200	1
10*	Leg	16 x 16 x 250	4
11*	Cross Frame	16 x 16 x 268	6

Stove

	NAME	DATE	AGRIGEL		
DRAWN	Dan	06/25/25			
APPROVED			TITLE Stove		
MATERIAL					
TREATMENT			SIZE A4	DWG NO	REV
UNLESS OTHERWISE SPECIFIED DIMENSIONS ARE IN MILLIMETERS			FILE NAME: Stove.dft		
1 st ANGLE 2 PL ±0.02 3 PL ±0.005			SCALE:	WEIGHT:	SHEET 1 OF 12

REVISION HISTORY			
REV	DESCRIPTION	DATE	APPROVED

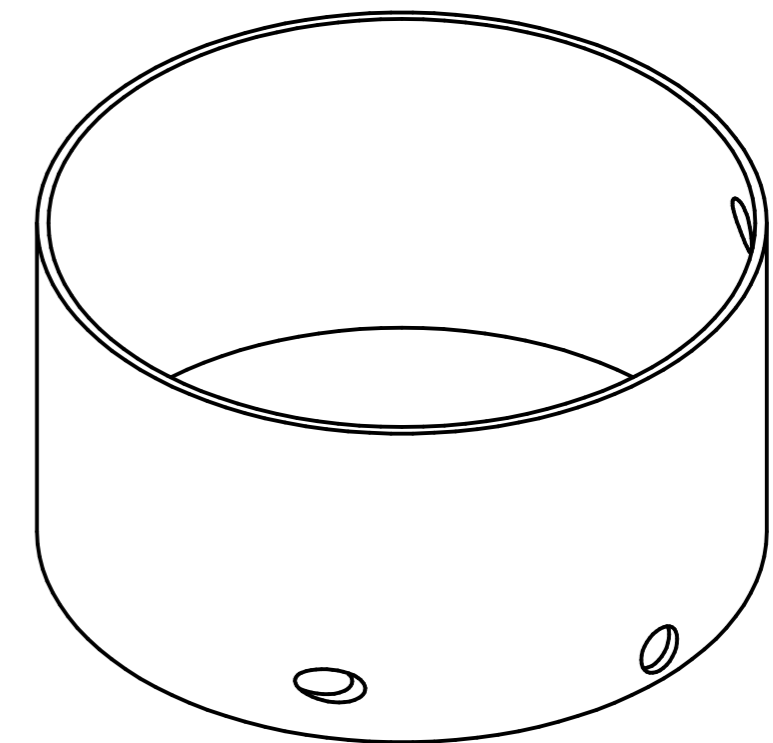
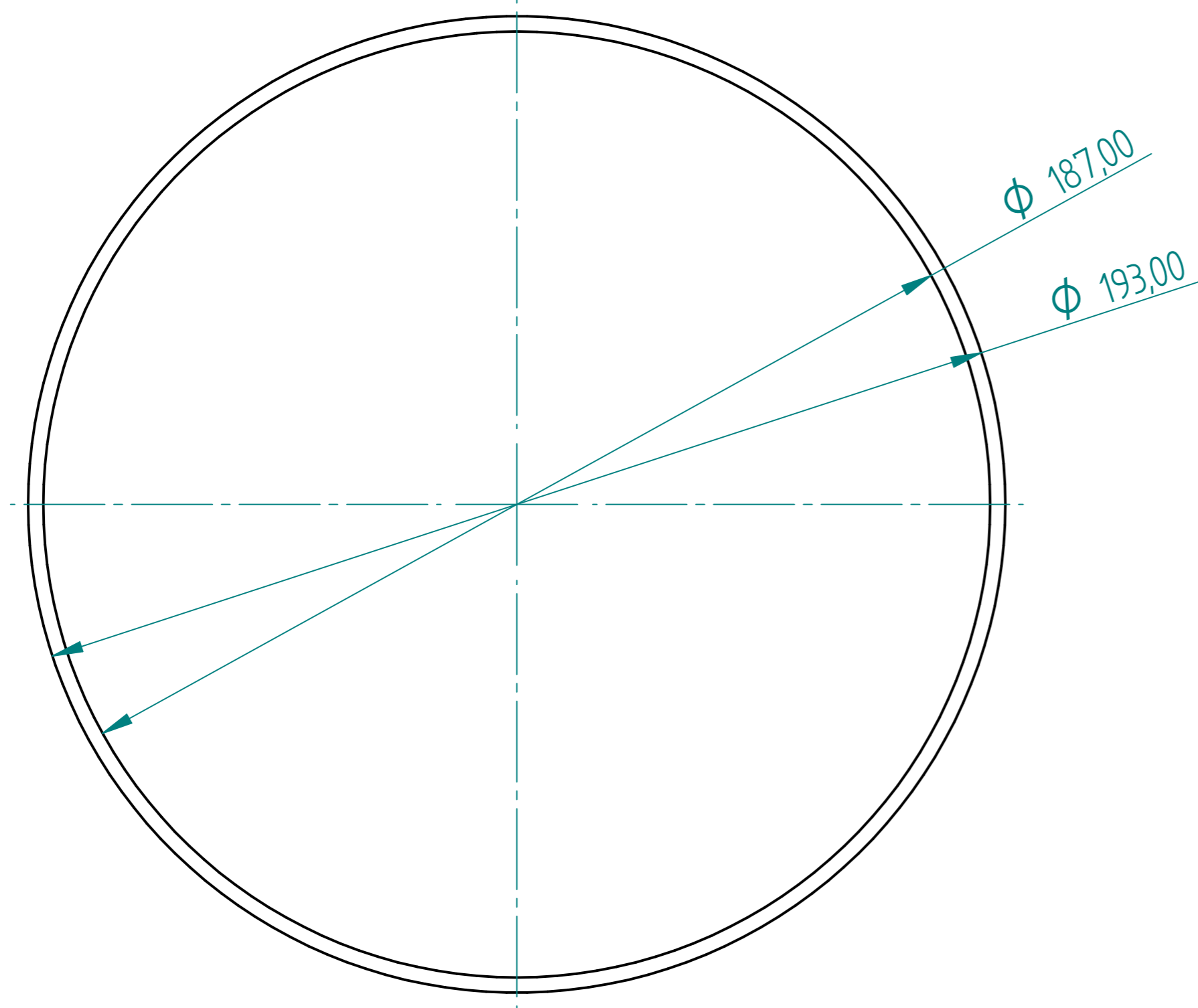
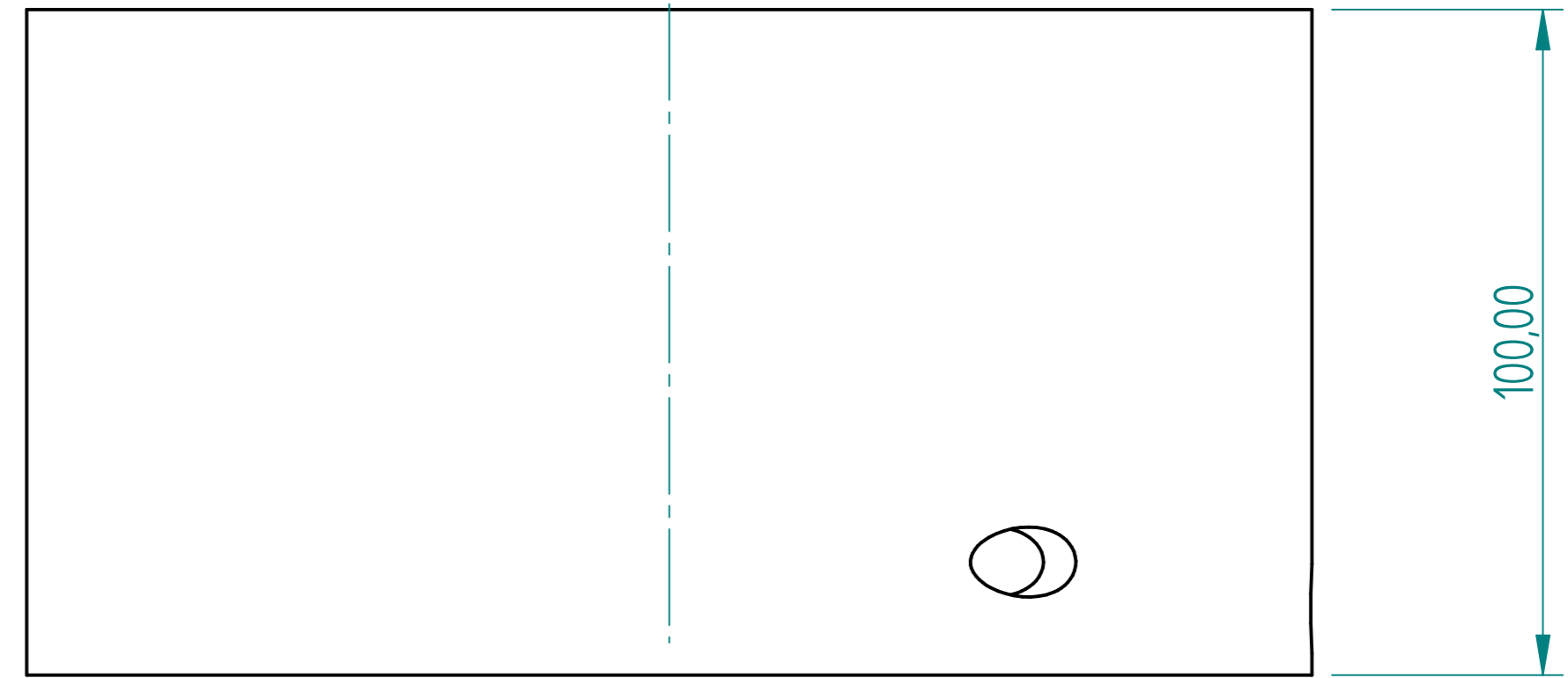
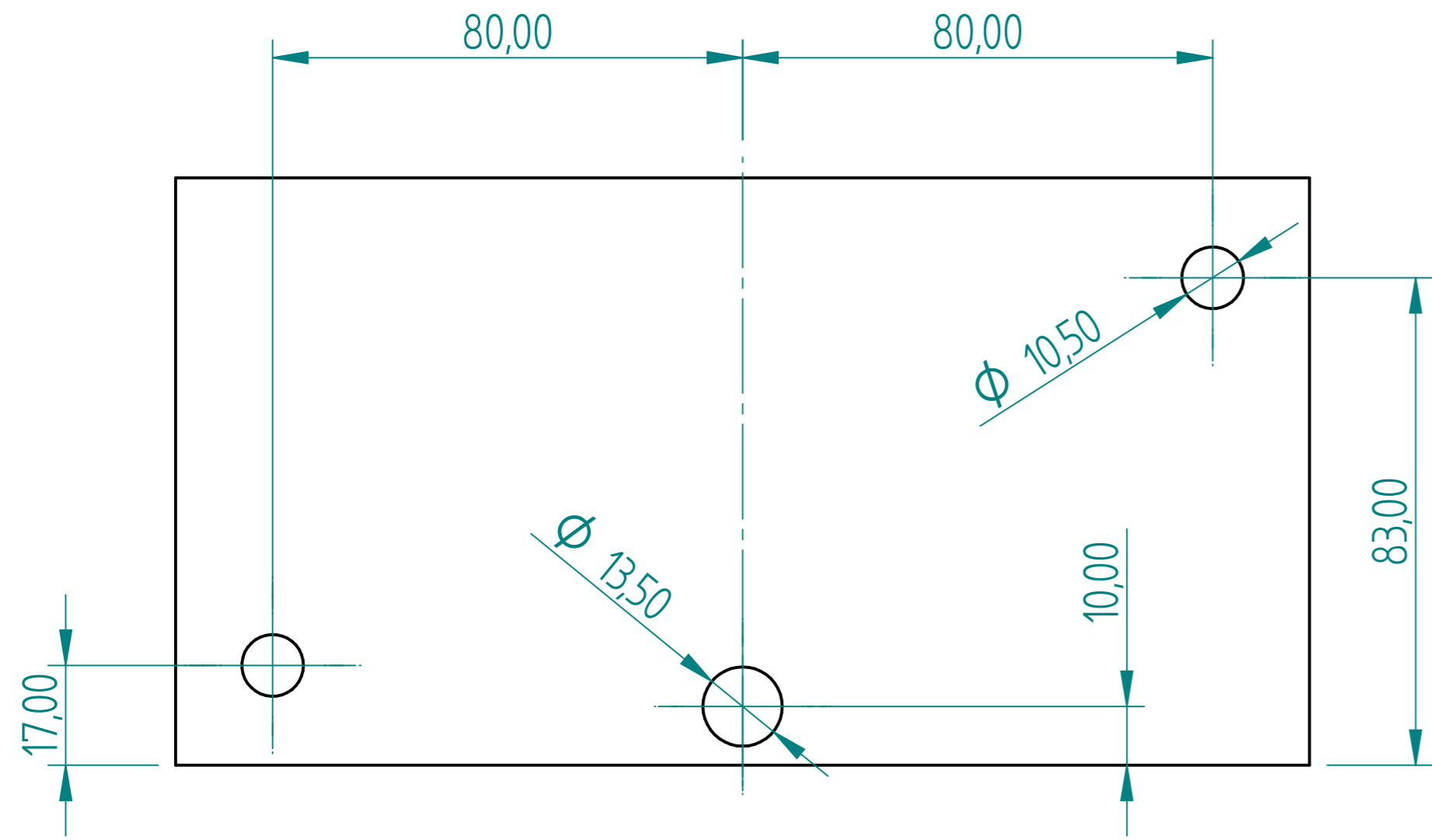

Burner Outer Tube

	NAME	DATE	AGRIGEL	
DRAWN	Dan	06/25/25	TITLE	
APPROVED			Stove	
MATERIAL			SIZE	DWG NO
TREATMENT			A4	
UNLESS OTHERWISE SPECIFIED DIMENSIONS ARE IN MILLIMETERS			FILE NAME: Stove.dft	REV
1 st ANGLE 2 PL ±0.02 3 PL ±0.005			SCALE:	WEIGHT:
				SHEET 2 OF 12

REVISION HISTORY			
REV	DESCRIPTION	DATE	APPROVED

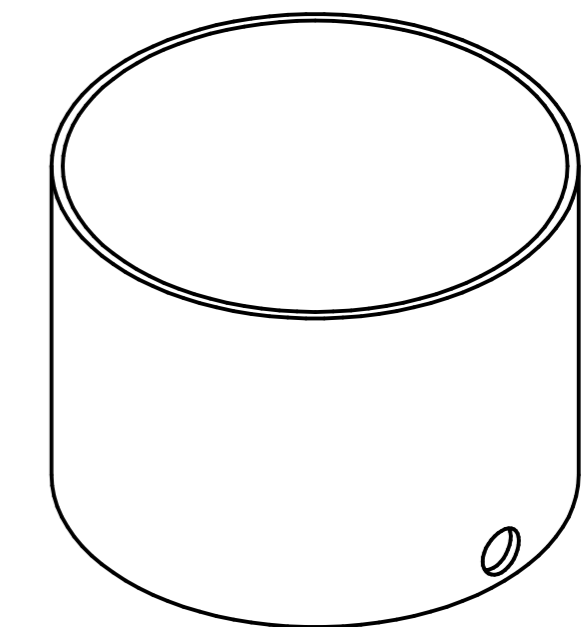
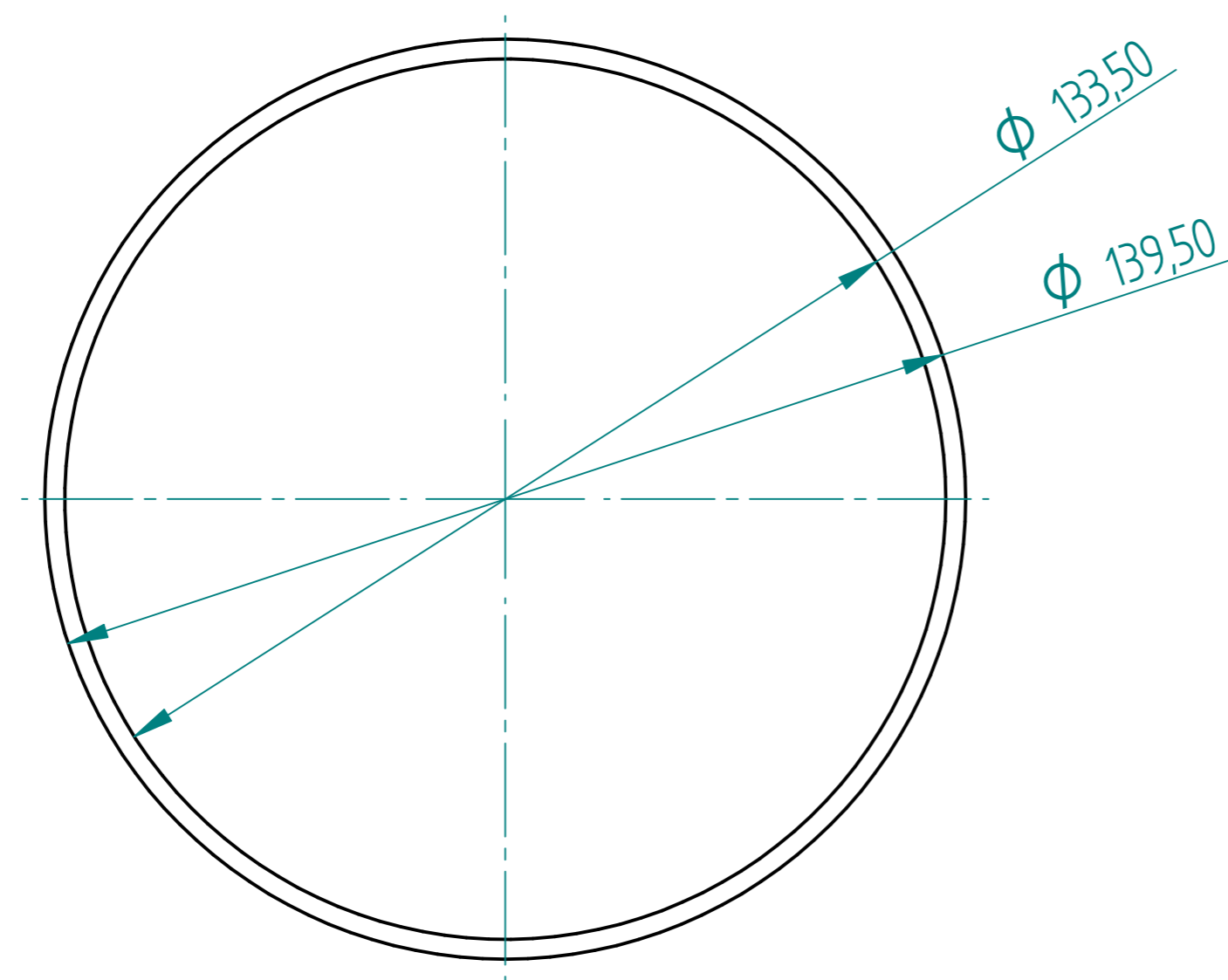
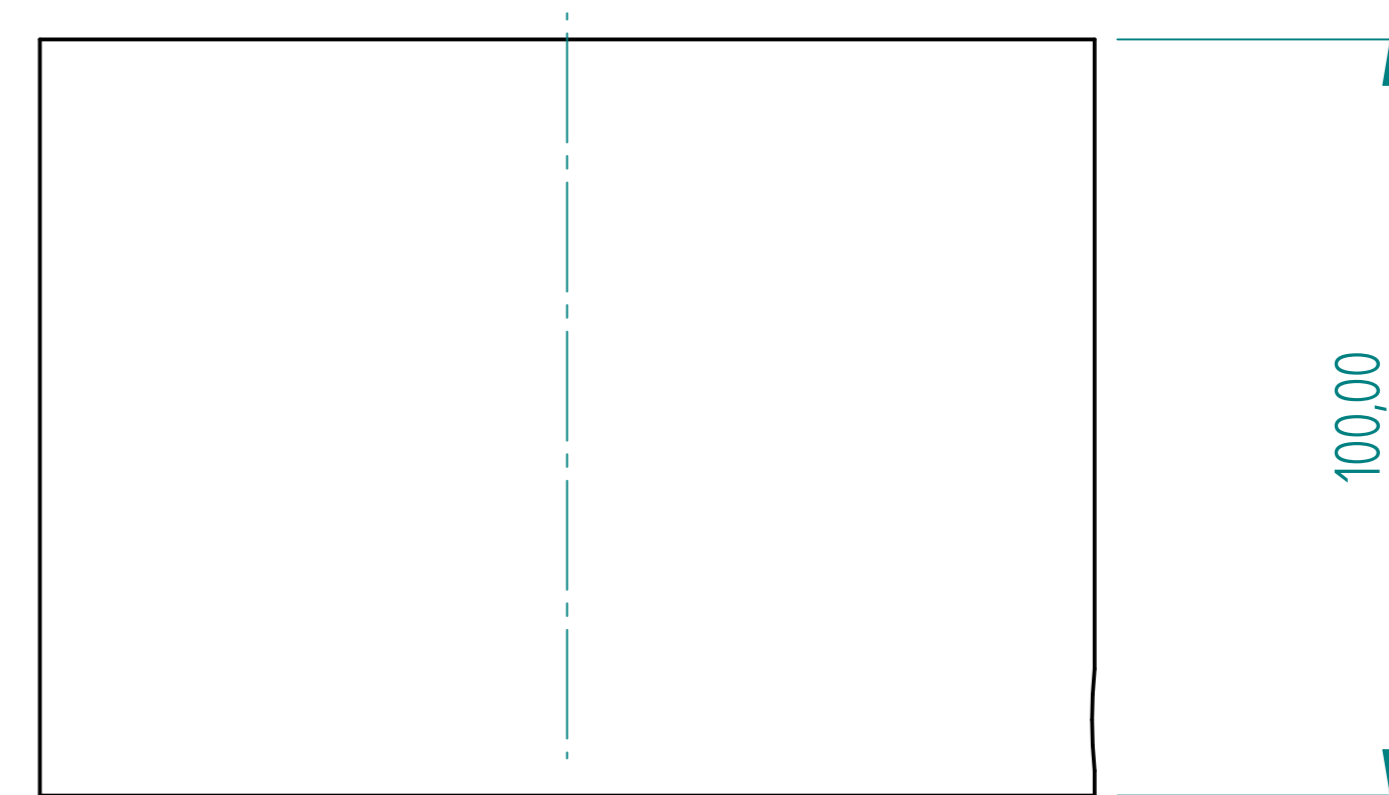
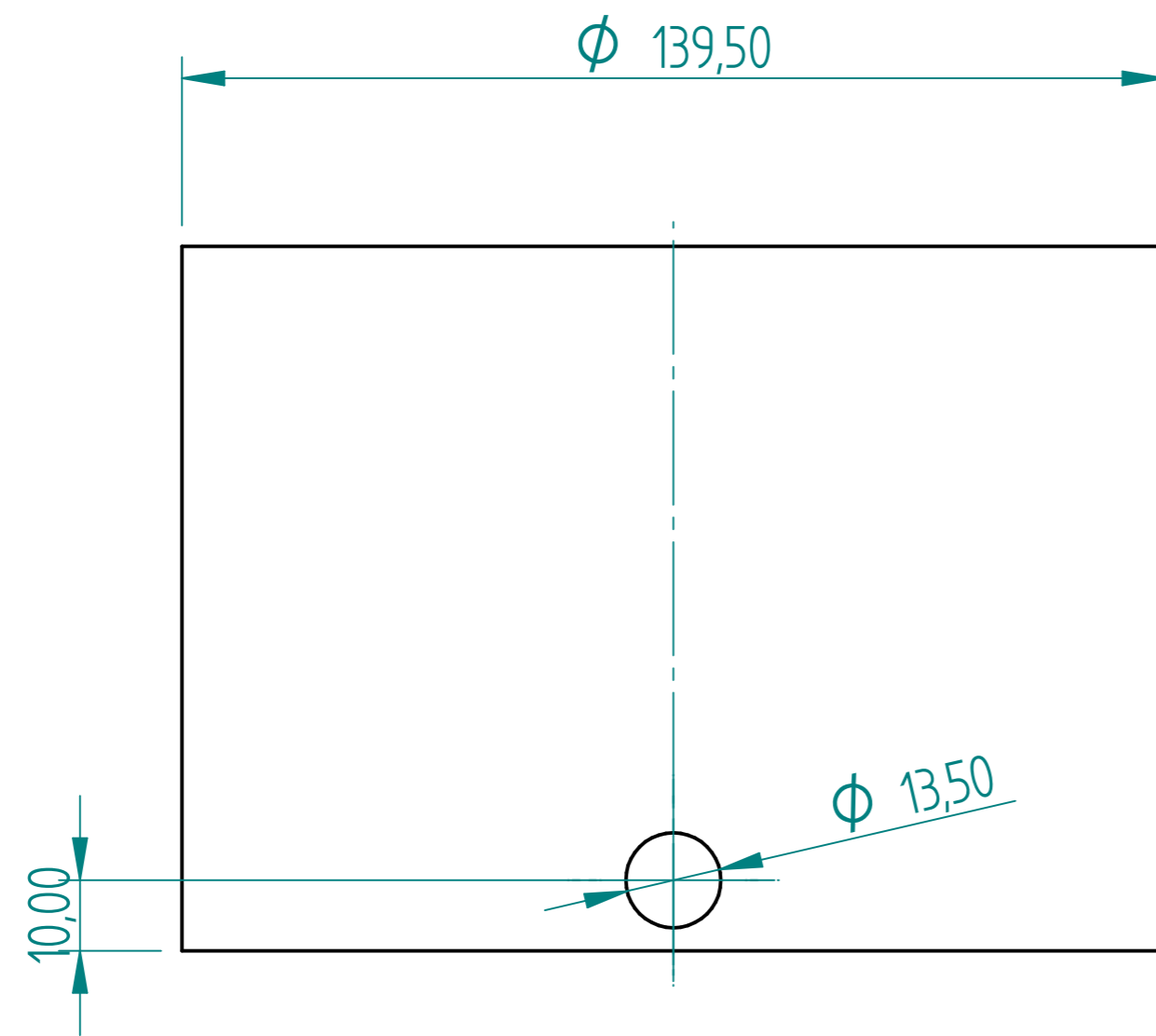

Burner Inner Tube

	NAME	DATE	AGRIGEL		
DRAWN	Dan	06/25/25			
APPROVED			TITLE Stove		
MATERIAL					
TREATMENT			SIZE A4	DWG NO	REV
UNLESS OTHERWISE SPECIFIED DIMENSIONS ARE IN MILLIMETERS			FILE NAME: Stove.dft		
1st ANGLE 2 PL ±0.02 3 PL ±0.005			SCALE:	WEIGHT:	SHEET 3 OF 12

REVISION HISTORY			
REV	DESCRIPTION	DATE	APPROVED

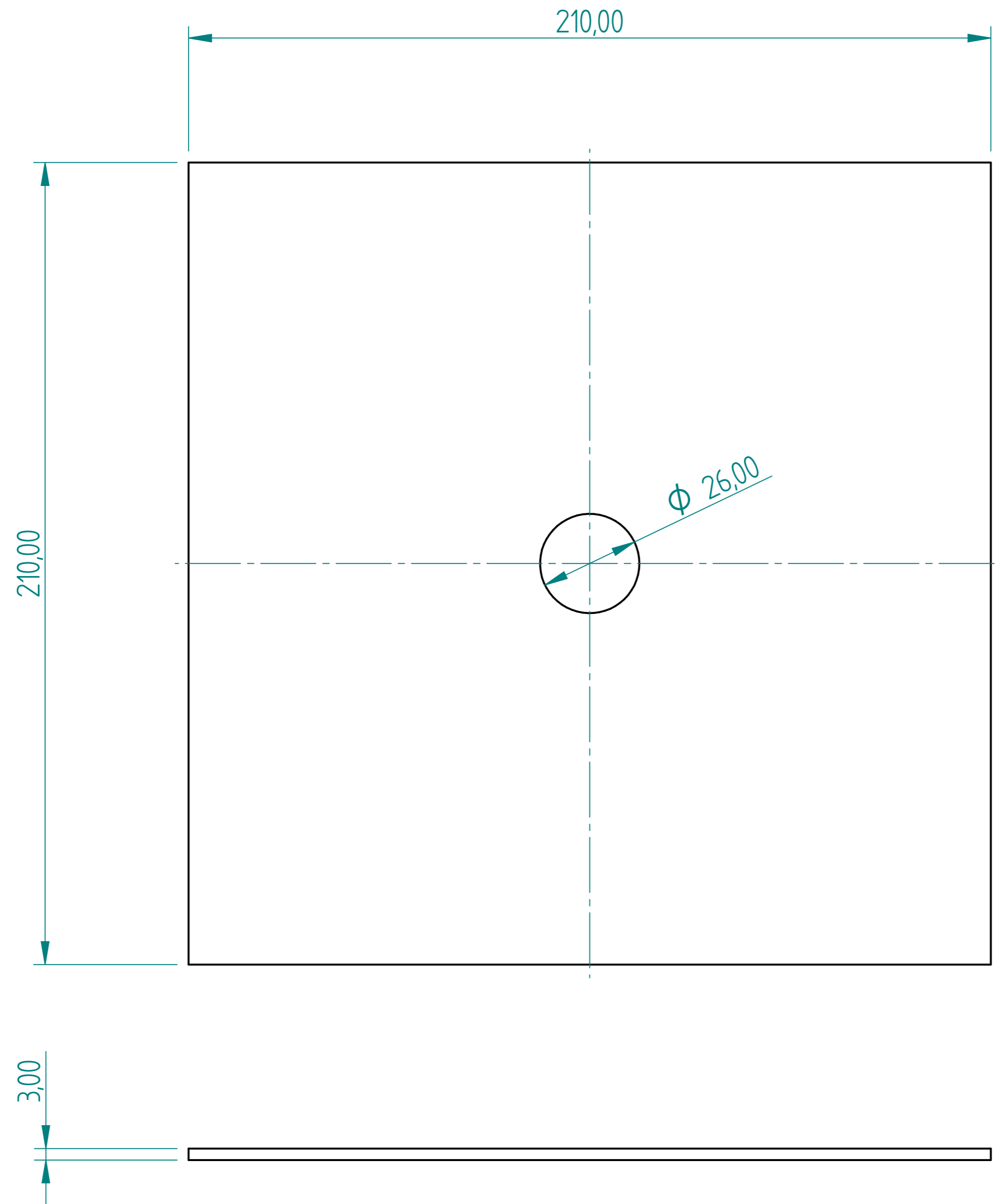

Base Plate

	NAME	DATE	AGRIGEL	
DRAWN	Dan	06/25/25	TITLE	
APPROVED			Stove	
MATERIAL			SIZE	DWG NO
TREATMENT			A4	
UNLESS OTHERWISE SPECIFIED DIMENSIONS ARE IN MILLIMETERS			FILE NAME: Stove.dft	REV
1 st ANGLE ANGLES $\pm 0.1^\circ$			SCALE:	WEIGHT:
2 PL ± 0.02 3 PL ± 0.005				SHEET 4 OF 12

REVISION HISTORY			
REV	DESCRIPTION	DATE	APPROVED

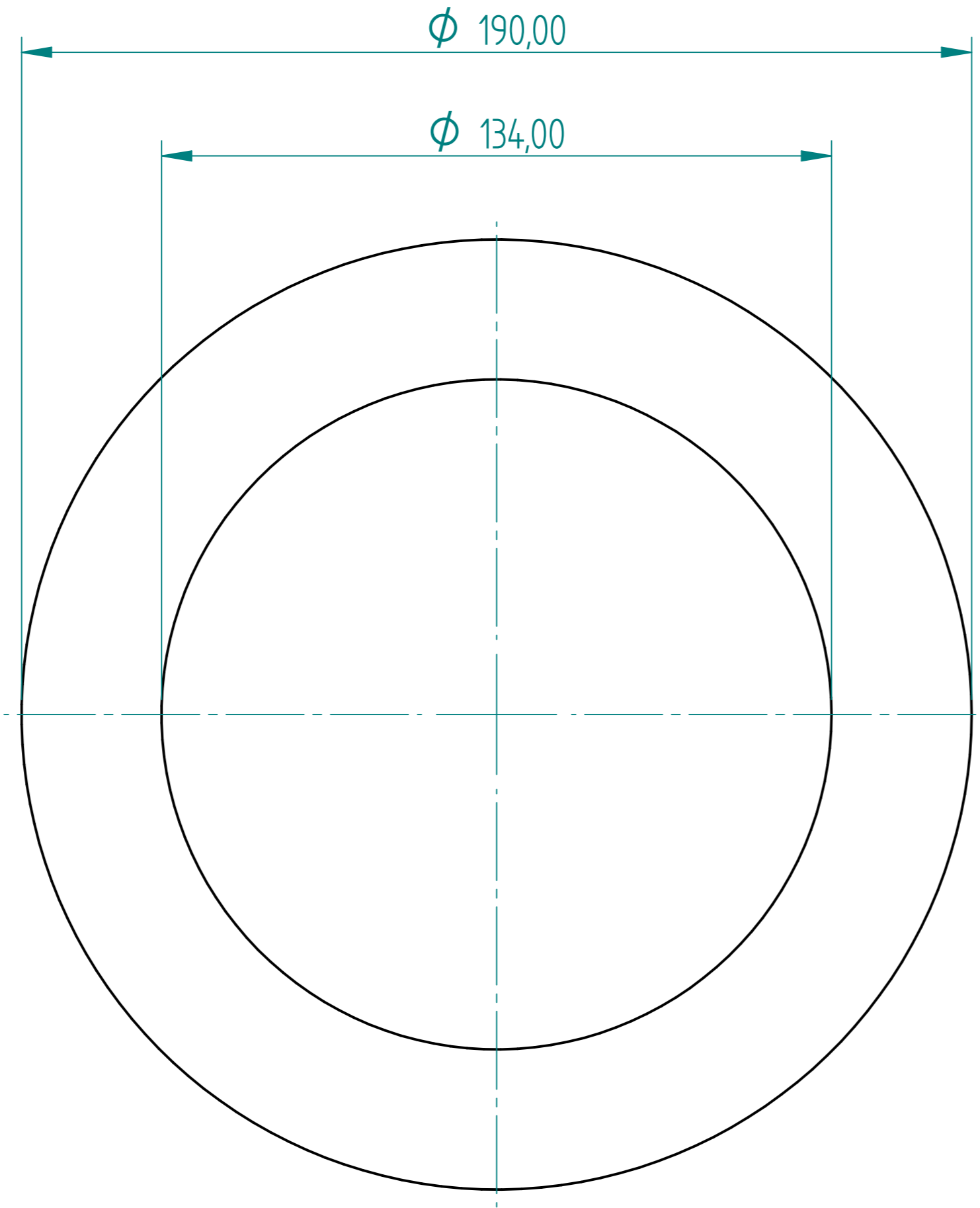

3,00

Burner Top

	NAME	DATE	AGRIGEL		
DRAWN	Dan	06/25/25			
APPROVED					
MATERIAL					
TREATMENT			TITLE Stove		
UNLESS OTHERWISE SPECIFIED DIMENSIONS ARE IN MILLIMETERS			SIZE A4	DWG NO	REV
1 st ANGLE  ANGLES ±0.1° 2 PL ±0.02 3 PL ±0.005			FILE NAME: Stove.dft		
			SCALE:	WEIGHT:	SHEET 5 OF 12

REVISION HISTORY			
REV	DESCRIPTION	DATE	APPROVED

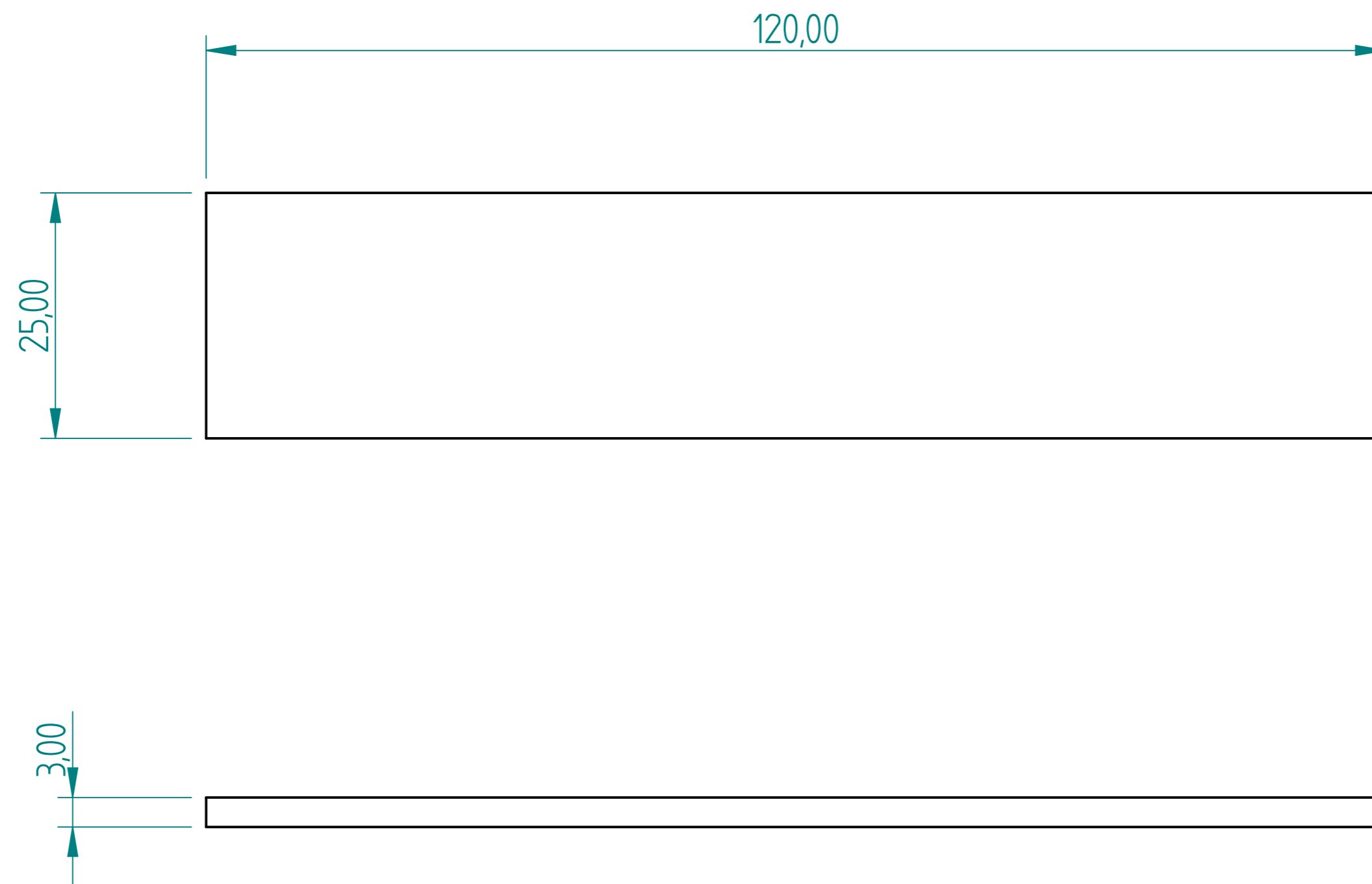

Pot Support

	NAME	DATE	AGRIGEL		
DRAWN	Dan	06/25/25			
APPROVED					
MATERIAL					
TREATMENT			TITLE Stove		
UNLESS OTHERWISE SPECIFIED DIMENSIONS ARE IN MILLIMETERS			SIZE A4	DWG NO	REV
1st ANGLE ANGLES ±0.1°			FILE NAME: Stove.dft		
2 PL ±0.02 3 PL ±0.005			SCALE:	WEIGHT:	SHEET 6 OF 12

REVISION HISTORY			
REV	DESCRIPTION	DATE	APPROVED

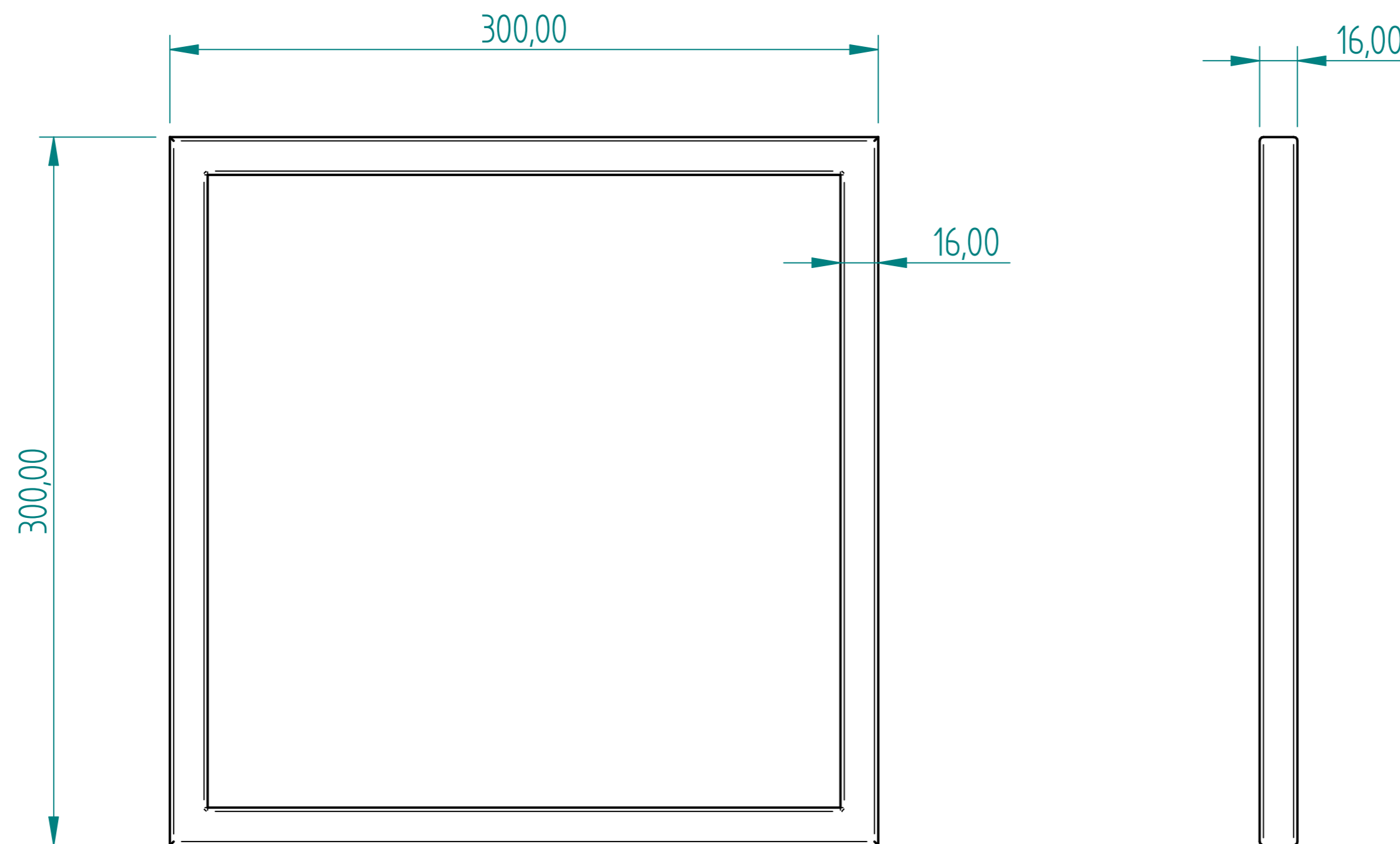
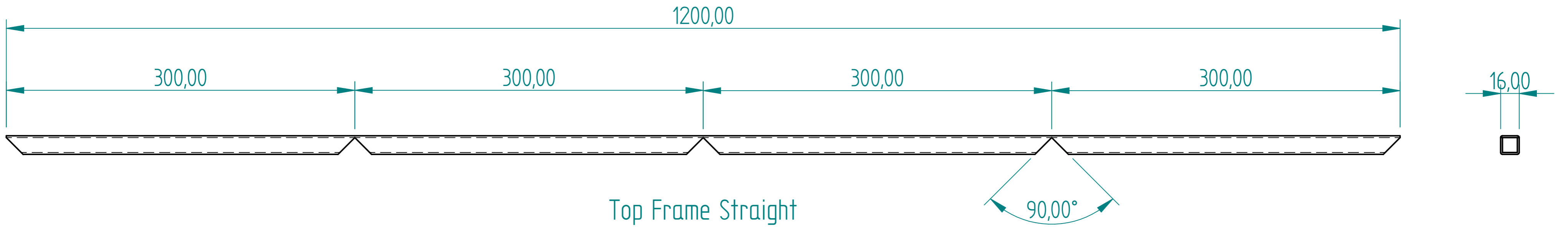

	NAME	DATE	AGRIGEL	
DRAWN	Dan	06/25/25	TITLE	
APPROVED			Stove	
MATERIAL			SIZE	DWG NO
TREATMENT			A4	
UNLESS OTHERWISE SPECIFIED DIMENSIONS ARE IN MILLIMETERS			FILE NAME: Stove.dft	REV
1st ANGLE 2 PL ±0.02 3 PL ±0.005			SCALE:	WEIGHT:
			SHEET 7 OF 12	

REVISION HISTORY			
REV	DESCRIPTION	DATE	APPROVED

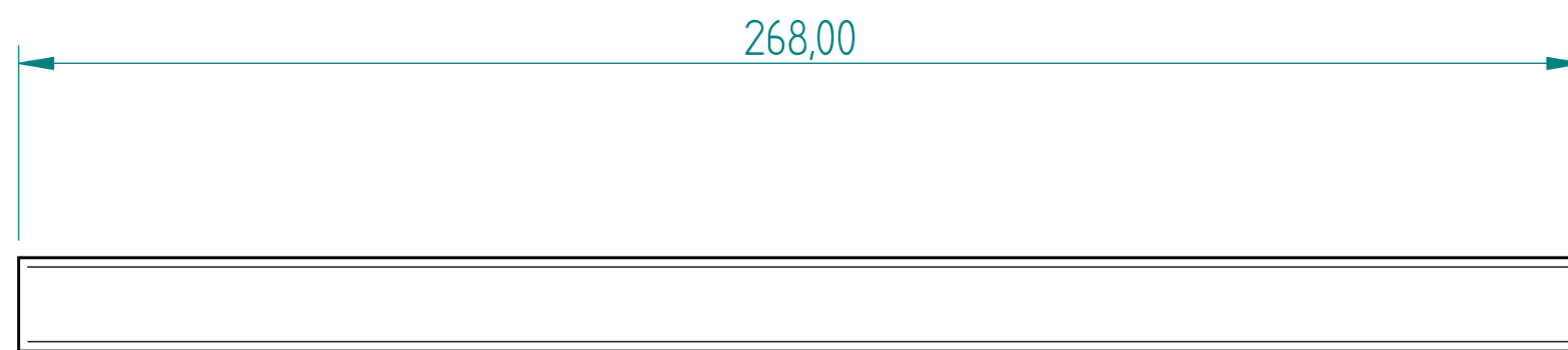

Cross Frame

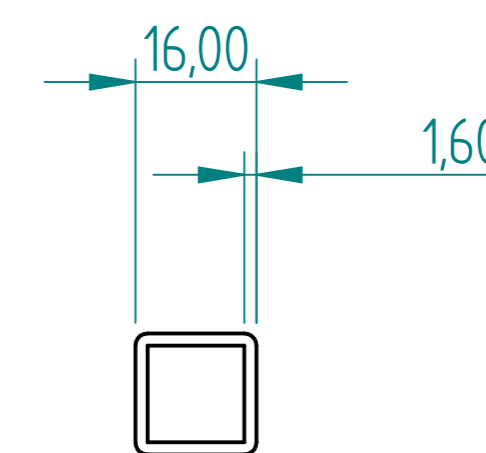

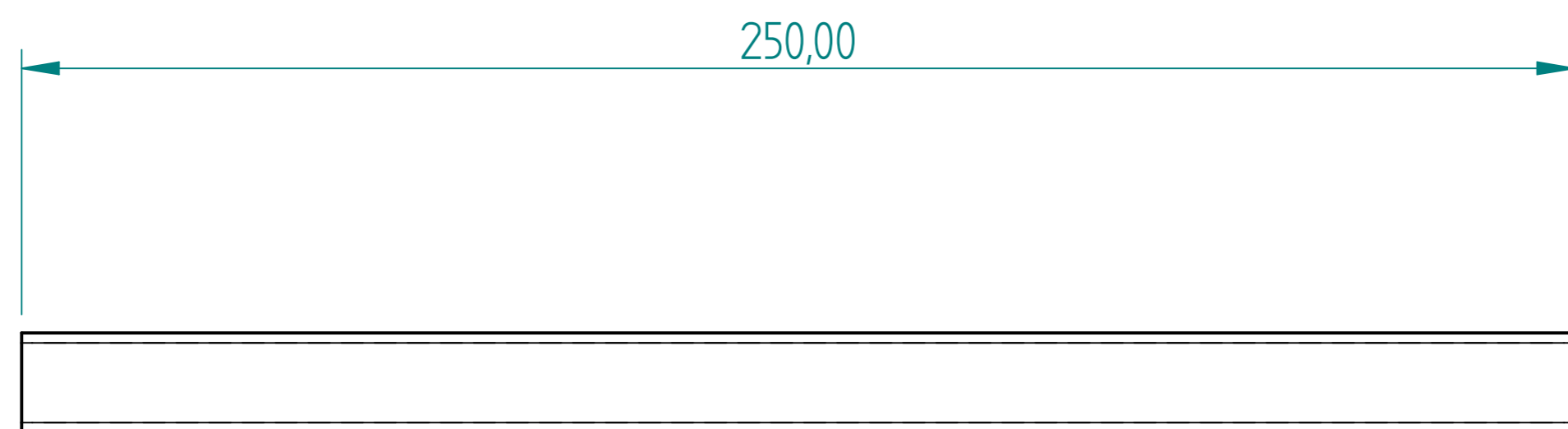

	NAME	DATE	AGRIGEL	
DRAWN	Dan	06/25/25		
APPROVED			TITLE Stove	
MATERIAL				
TREATMENT			SIZE A4	
UNLESS OTHERWISE SPECIFIED DIMENSIONS ARE IN MILLIMETERS				
1 st ANGLE 2 PL ±0.02 3 PL ±0.005			FILE NAME: Stove.dft	
			SCALE:	WEIGHT:
			SHEET 8 OF 12	

REVISION HISTORY			
REV	DESCRIPTION	DATE	APPROVED

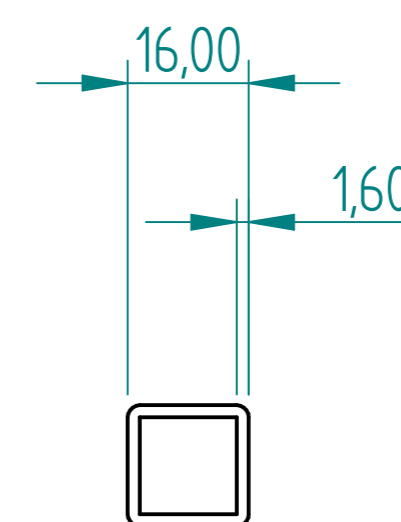

Leg



	NAME	DATE	AGRIGEL		
DRAWN	Dan	06/25/25			
APPROVED					
MATERIAL					
TREATMENT			TITLE		
			Stove		
UNLESS OTHERWISE SPECIFIED DIMENSIONS ARE IN MILLIMETERS			SIZE A4	DWG NO	REV
1st ANGLE  2 PL ±0.02 3 PL ±0.005			FILE NAME: Stove.dft		
			SCALE:	WEIGHT:	SHEET 9 OF 12

REVISION HISTORY			
REV	DESCRIPTION	DATE	APPROVED

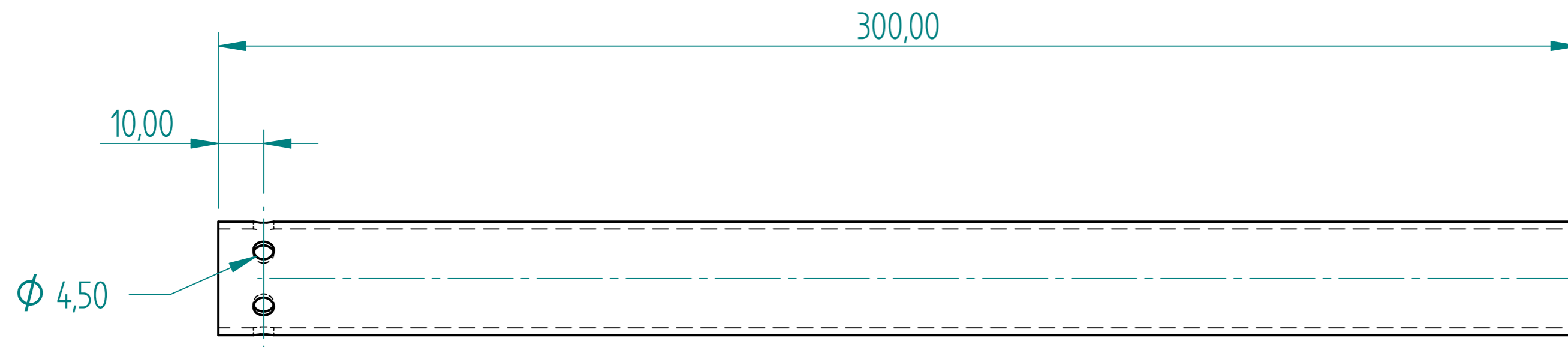

Burner Pipe Straight

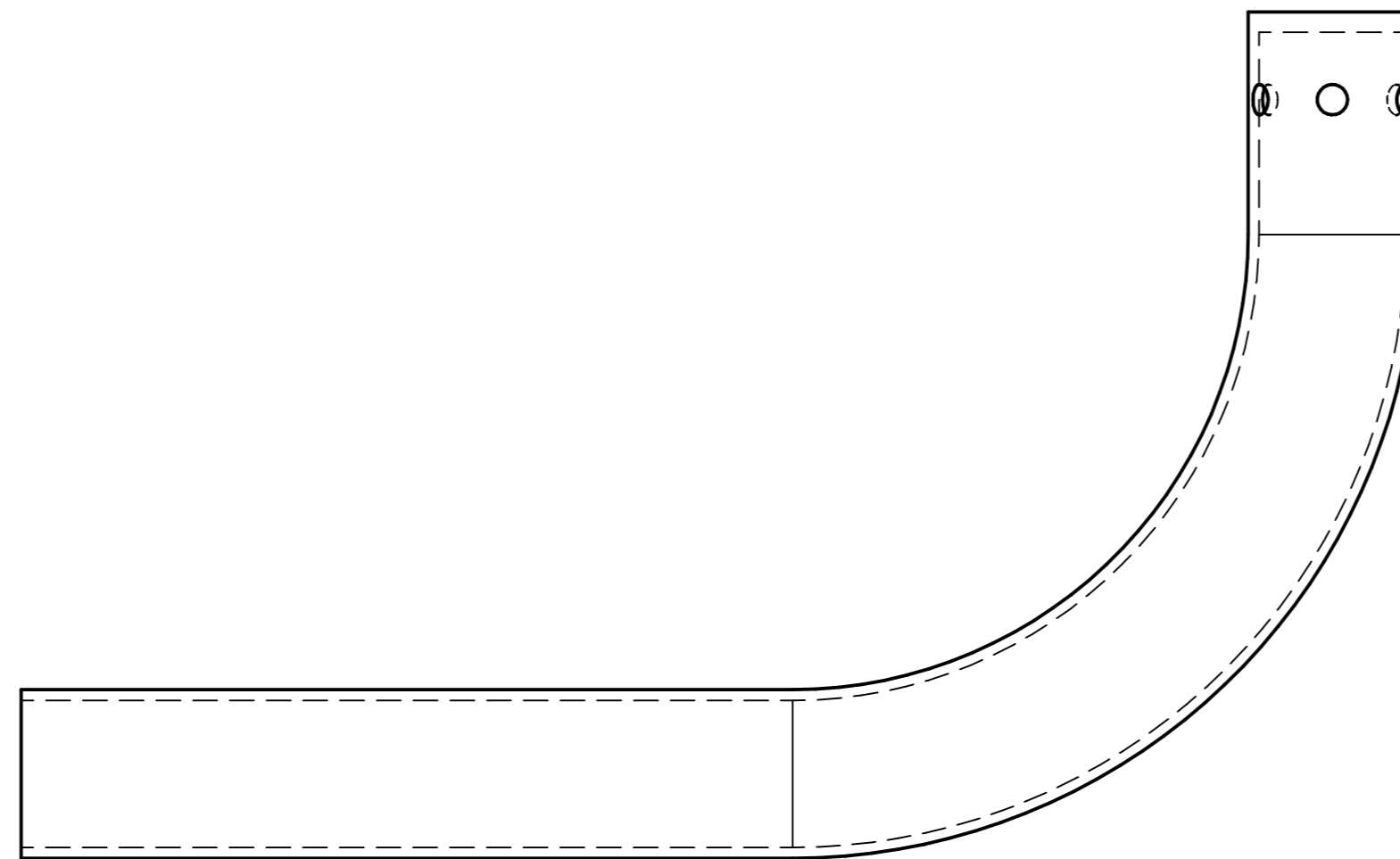
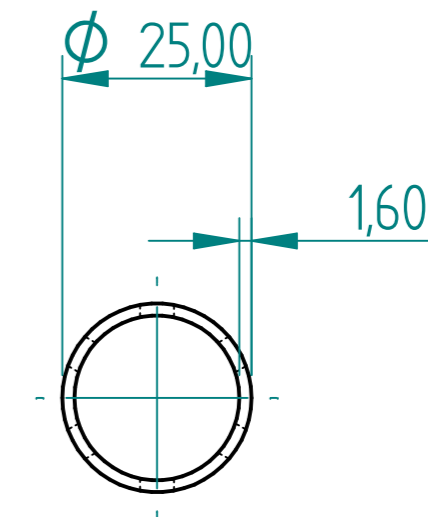

Burner Pipe

	NAME	DATE	AGRIGEL		
DRAWN	Dan	06/25/25			
APPROVED					
MATERIAL					
TREATMENT			TITLE Stove		
UNLESS OTHERWISE SPECIFIED DIMENSIONS ARE IN MILLIMETERS			SIZE A4	DWG NO	REV
1 st ANGLE ANGLES ±0.1°			FILE NAME: Stove.dft		
2 PL ±0.02 3 PL ±0.005			SCALE:	WEIGHT:	SHEET 10 OF 12

REVISION HISTORY			
REV	DESCRIPTION	DATE	APPROVED

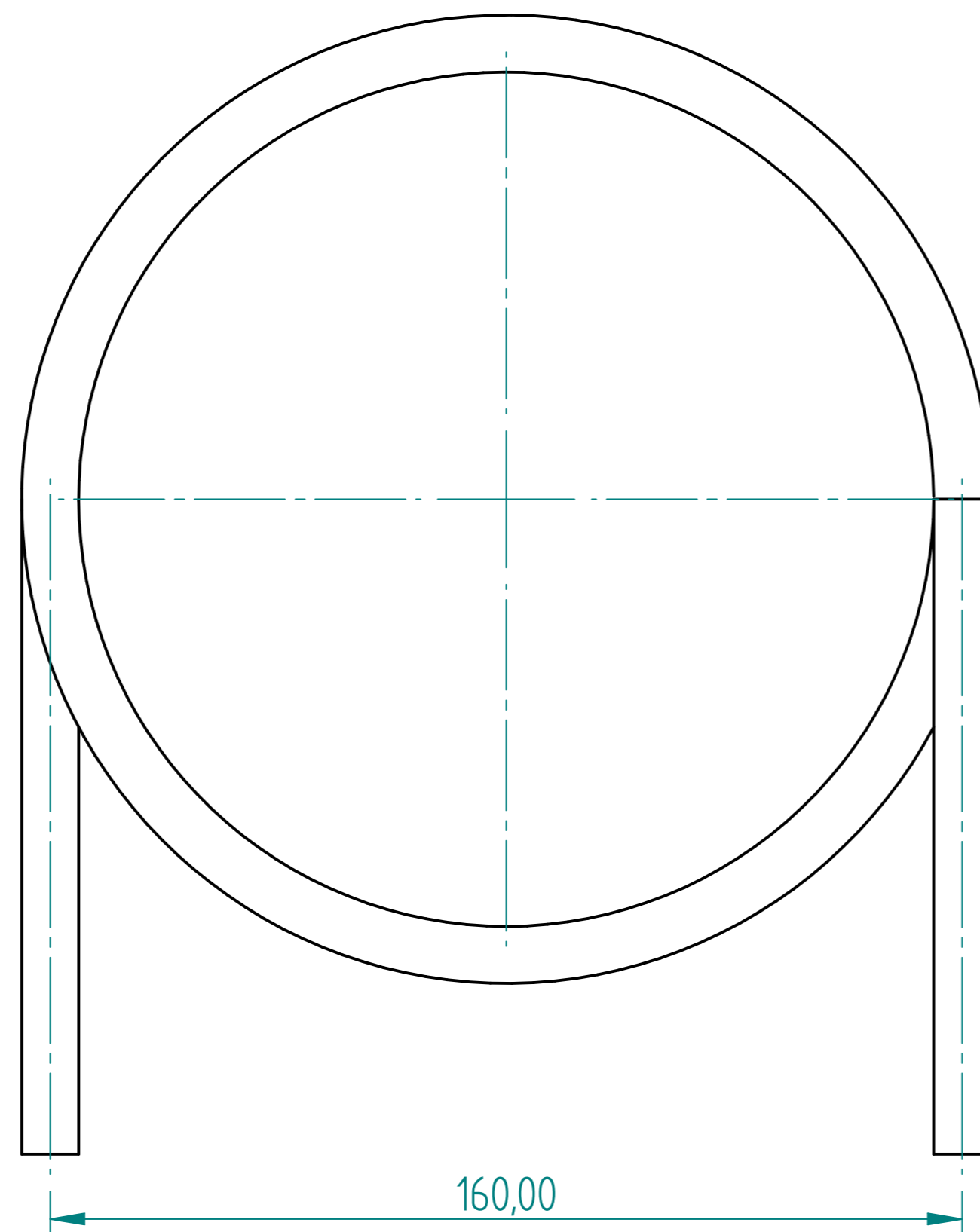
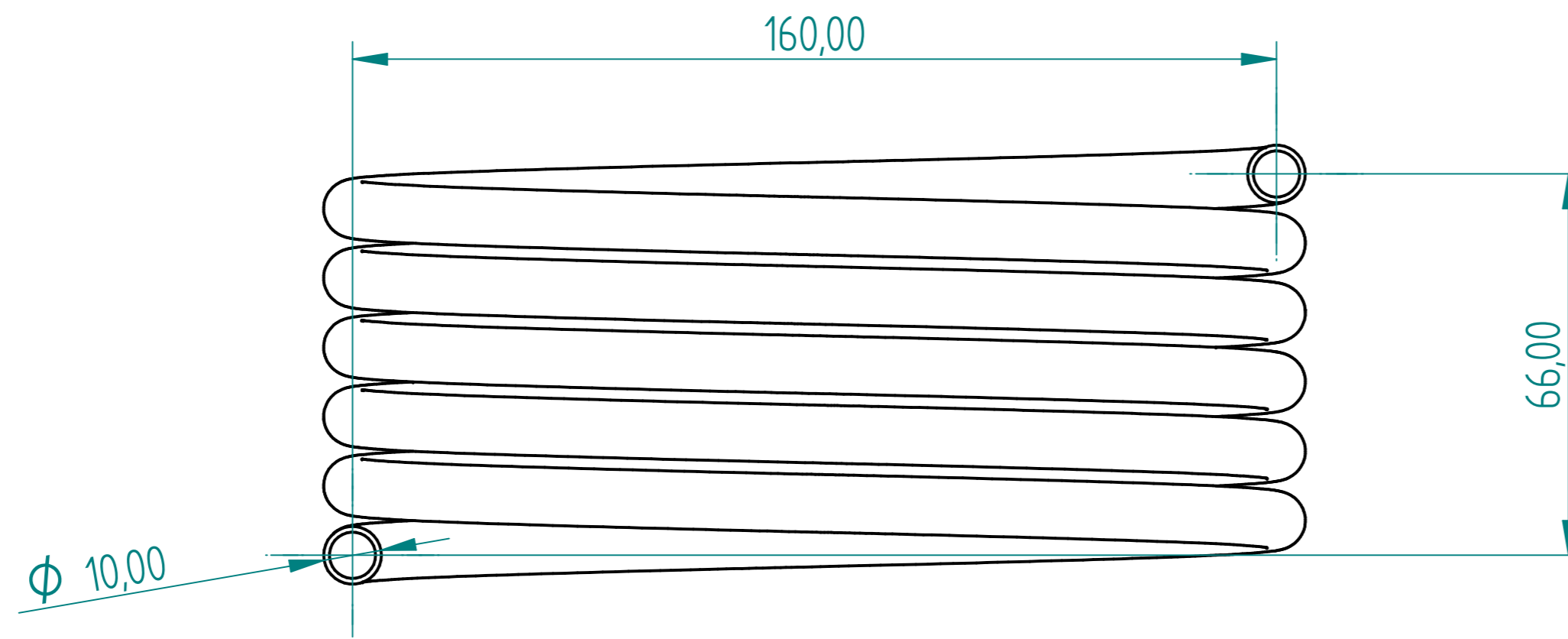

Water Heater Pipe

	NAME	DATE	AGRIGEL		
DRAWN	Dan	06/25/25			
APPROVED			TITLE Stove		
MATERIAL					
TREATMENT			SIZE A4	DWG NO	REV
UNLESS OTHERWISE SPECIFIED DIMENSIONS ARE IN MILLIMETERS			FILE NAME: Stove.dft		
1 st ANGLE  2 PL ±0.02 3 PL ±0.005			SCALE:	WEIGHT:	SHEET 11 OF 12

REVISION HISTORY			
REV	DESCRIPTION	DATE	APPROVED

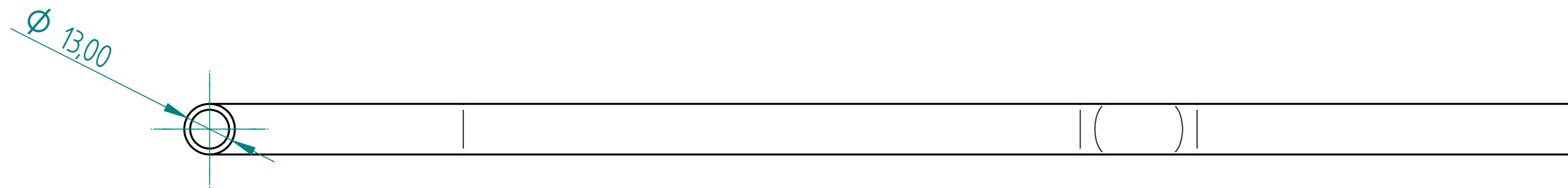
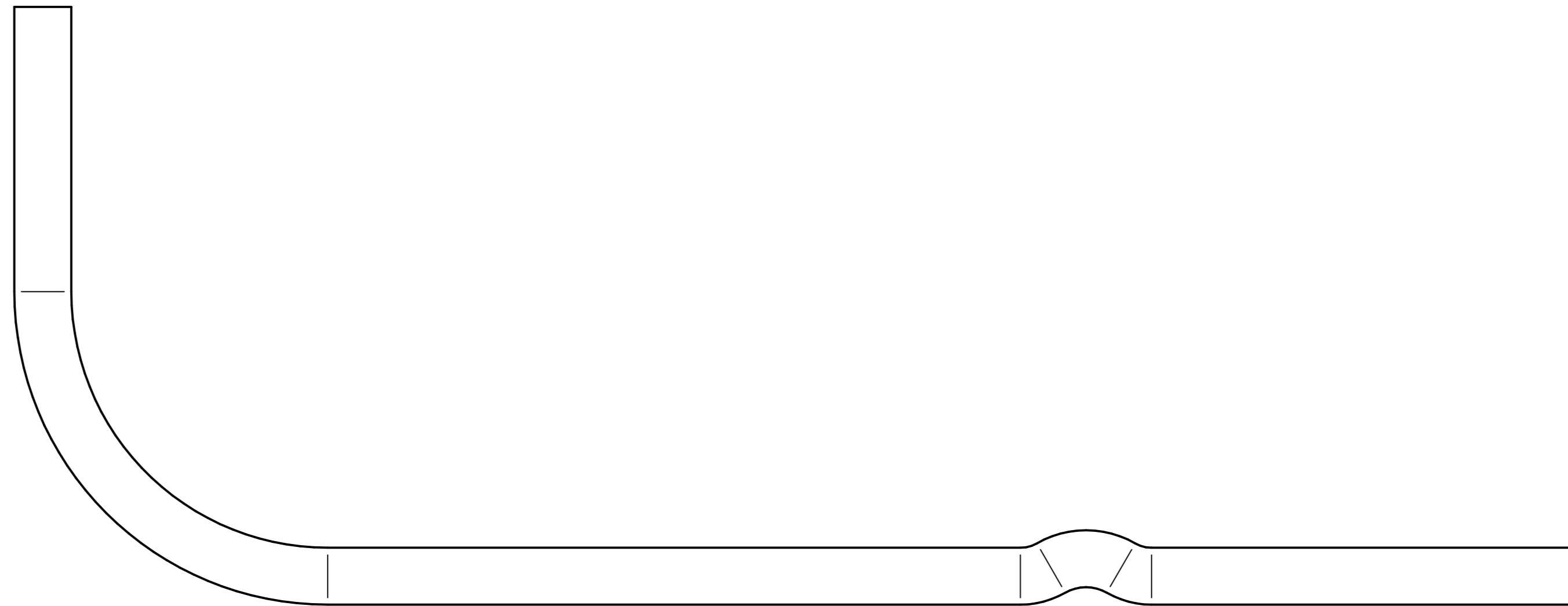

Oil Pipe

	NAME	DATE	AGRIGEL		
DRAWN	Dan	06/25/25			
APPROVED					
MATERIAL					
TREATMENT			TITLE		
			Stove		
UNLESS OTHERWISE SPECIFIED DIMENSIONS ARE IN MILLIMETERS			SIZE A4	DWG NO	REV
1 st ANGLE  2 PL ±0.02 3 PL ±0.005			FILE NAME: Stove.dft		
			SCALE:	WEIGHT:	SHEET 12 OF 12