

REVISION HISTORY			
REV	DESCRIPTION	DATE	APPROVED

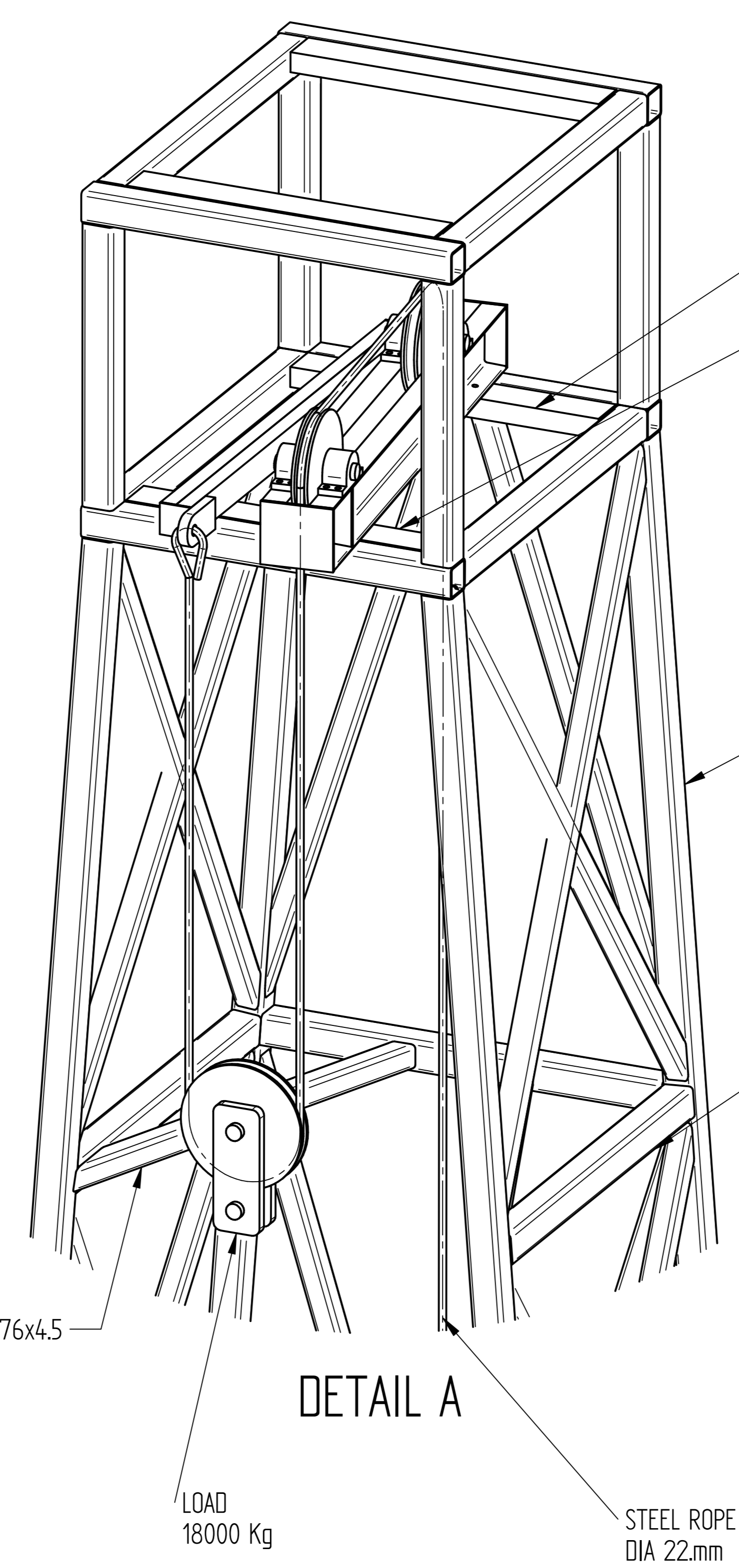

- SQUARE TUBING 100x100x6
- C-Channel 127x64
- C-Channel 127x64
- SQUARE TUBING 76x76x4.5
- SQUARE TUBING 76x76x4.5
- SQUARE TUBING 100x100x6
- SQUARE TUBING 100x100x6
- SQUARE TUBING 100x100x6

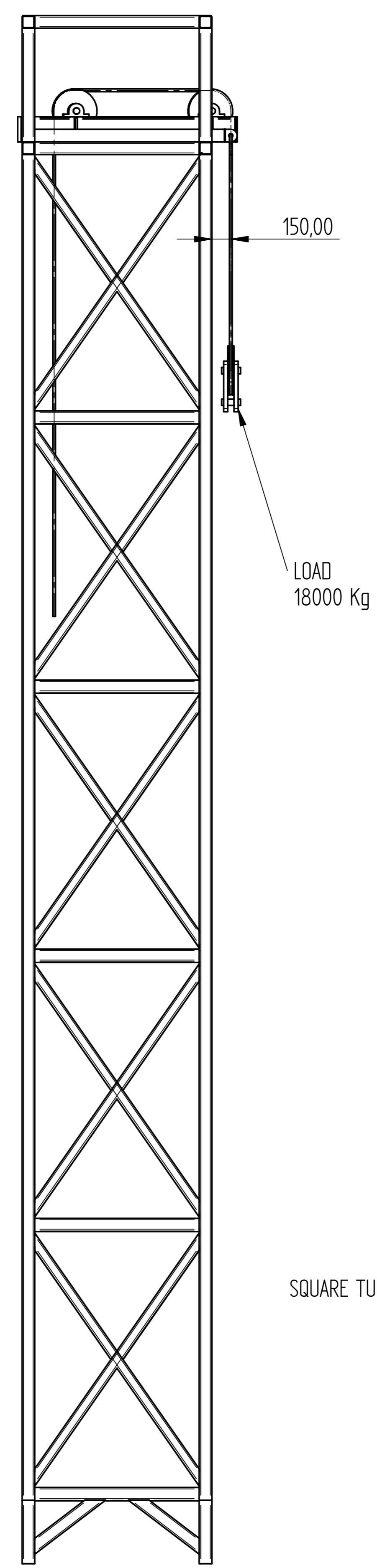
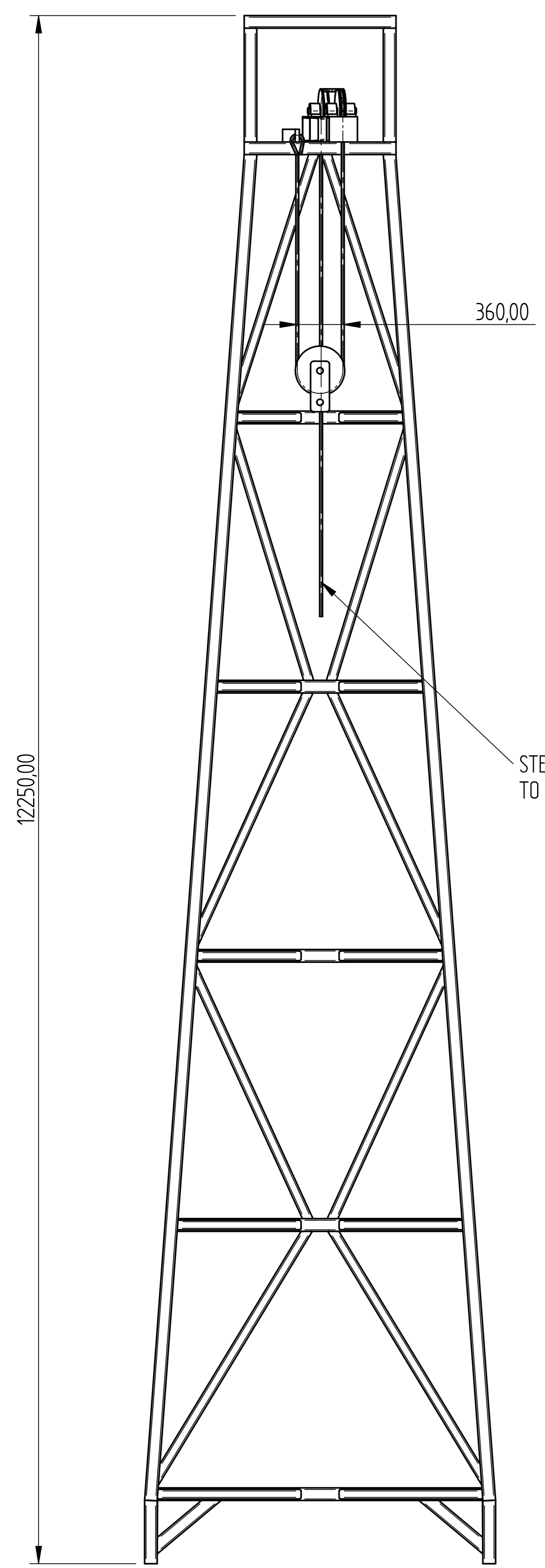
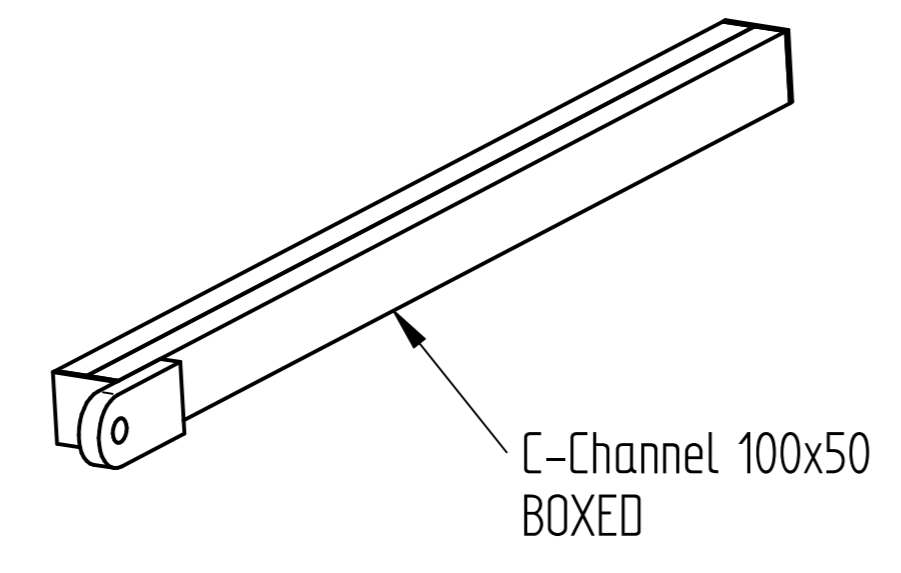
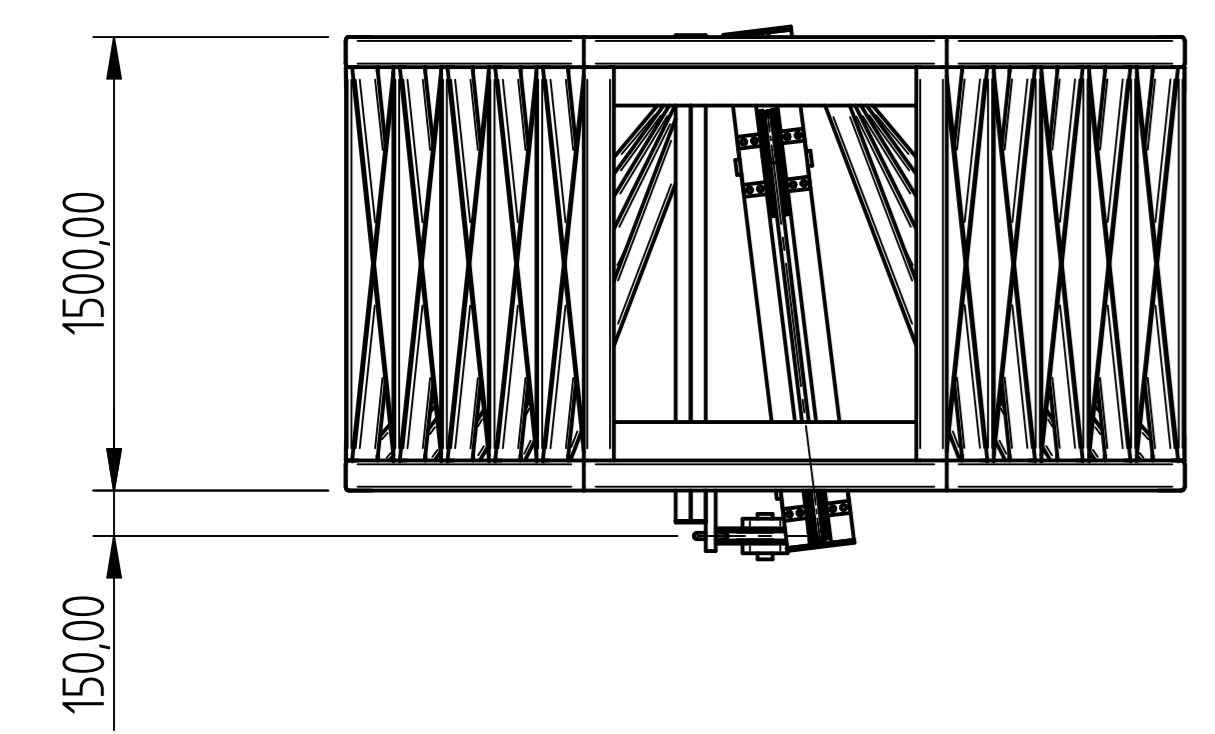
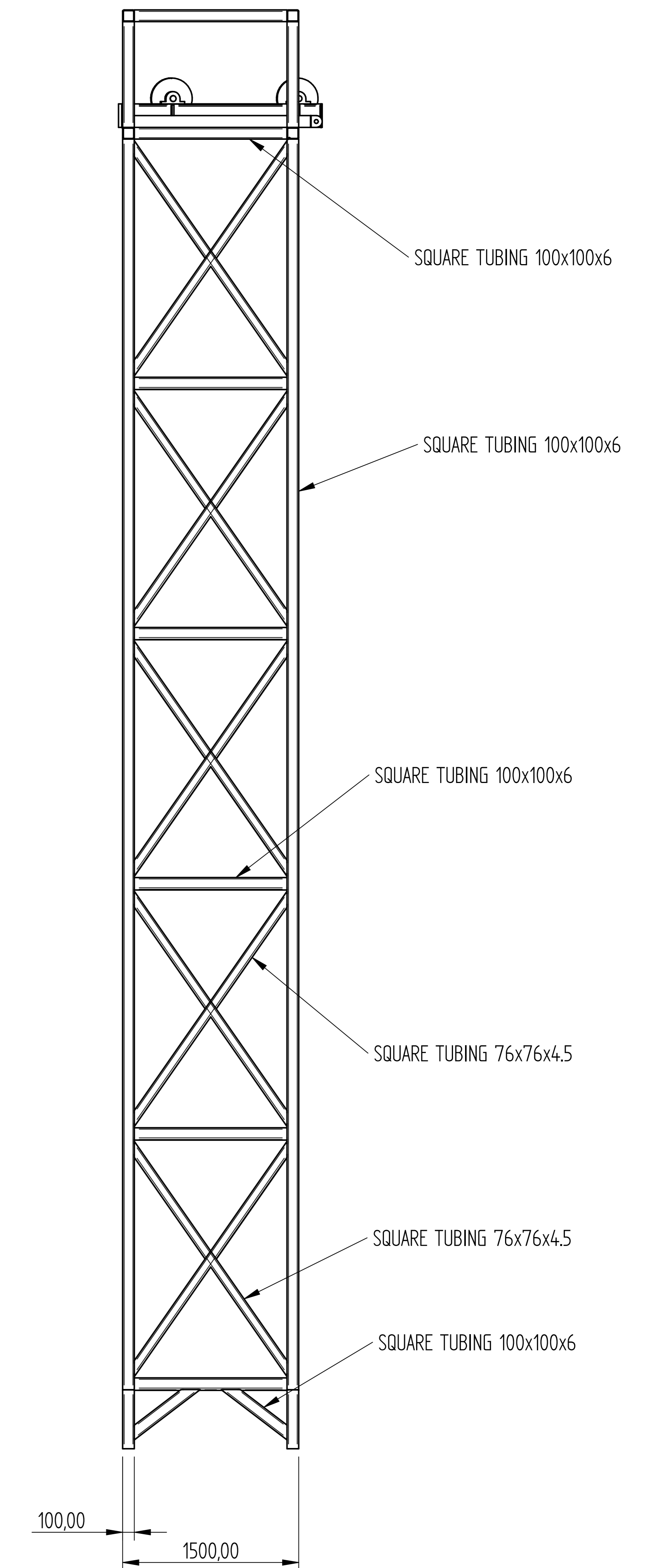
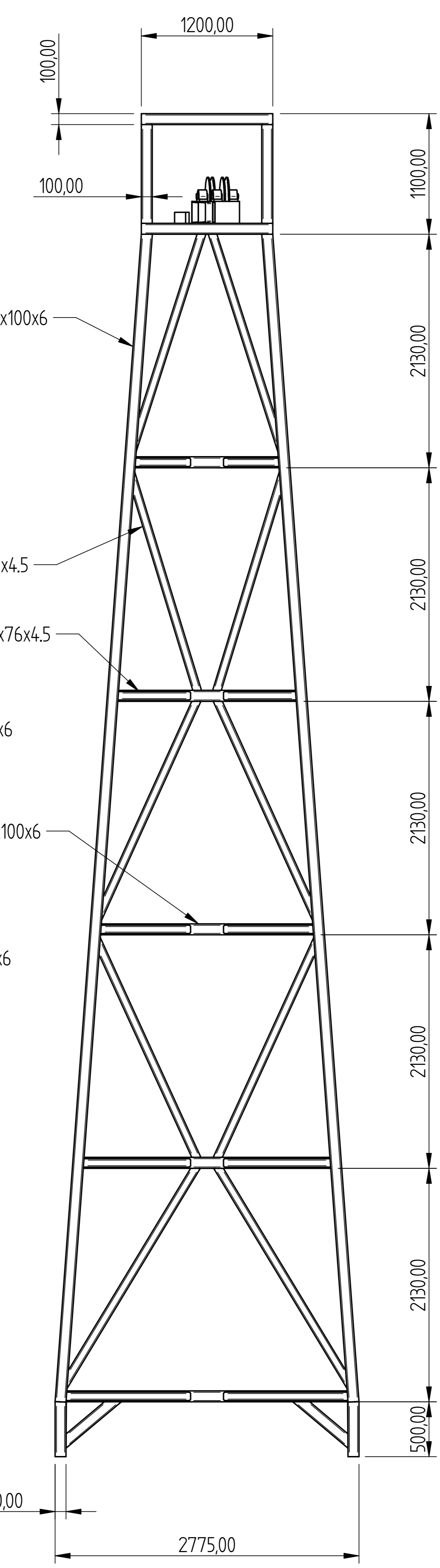

DEAD MAN ARM

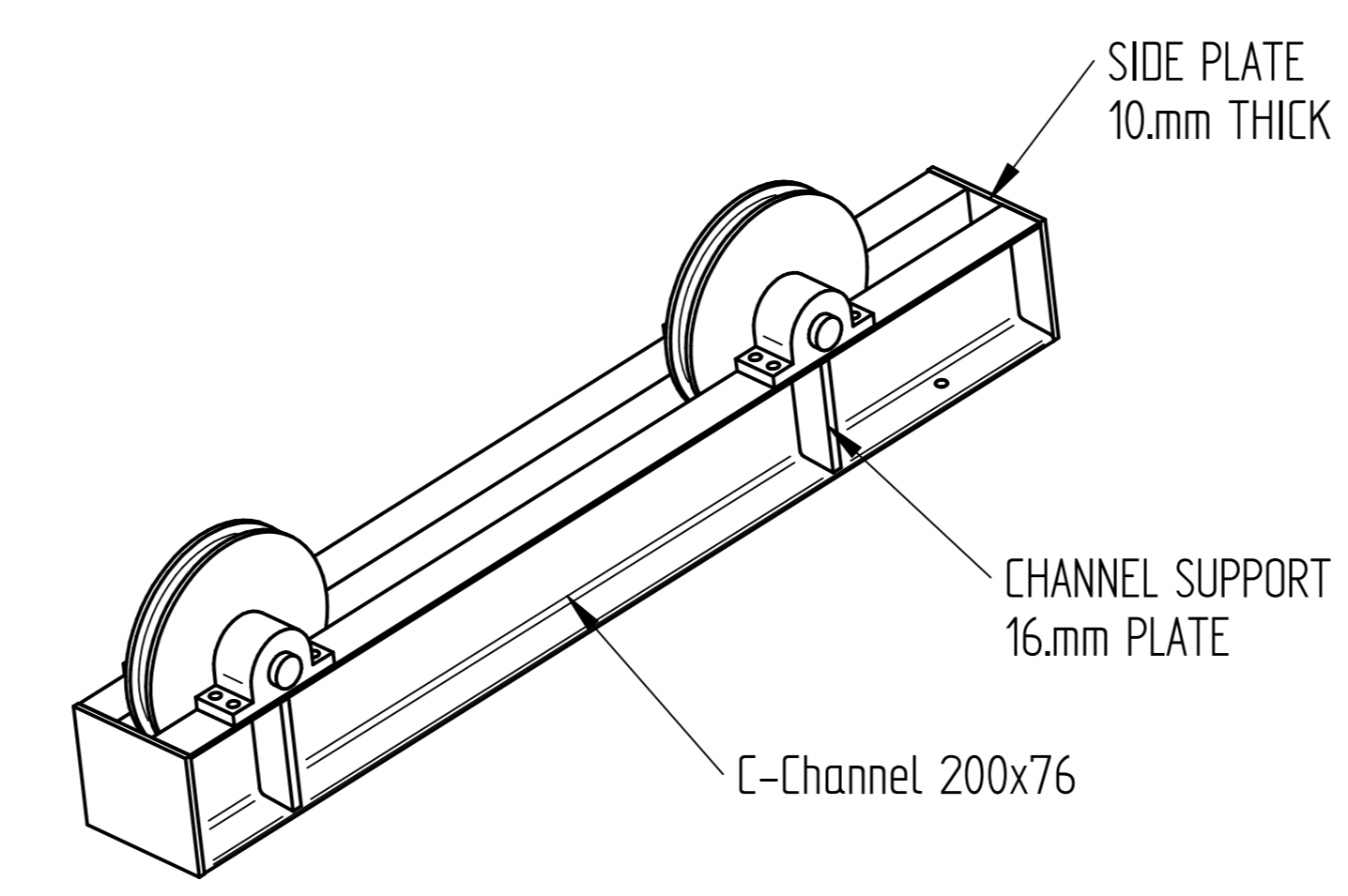

SHEAVE WHEEL BRACKET

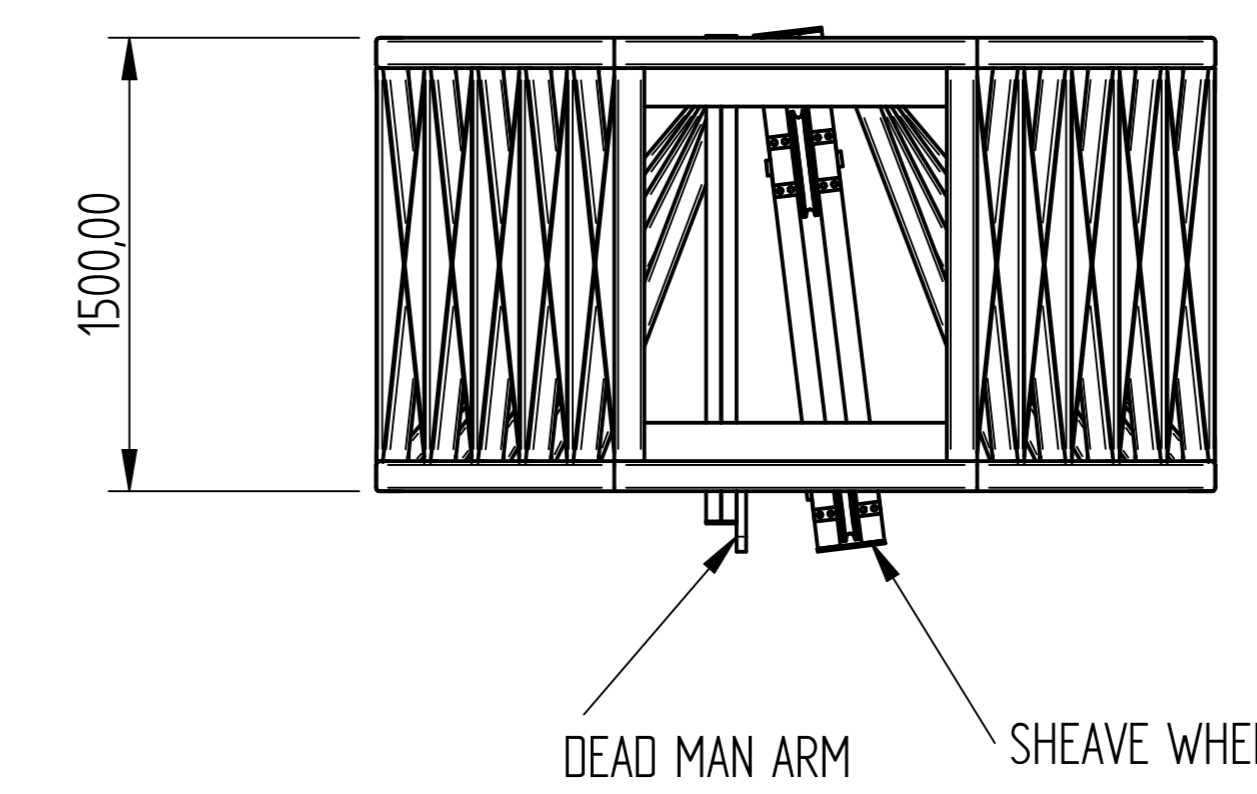

MATERIAL: SABS 1431 GRADE S355JR
ALL WELDING 10mm FILLET

NAME	DATE	EQUAL CHANCE TRADING 50	
DRAWN	DLG	05/18/11	TITLE
APPROVED			Derrick Frame 2800
MATERIAL			REV
TREATMENT			FILE NAME: Derrick Frame 2800.dft
UNLESS OTHERWISE SPECIFIED		SCALE	WEIGHT
DIMENSIONS ARE IN MILLIMETERS		2 PL +0.02	3 PL +0.005
ANGLES ±0.1°		SHEET 2 OF 2	