

REVISION HISTORY			
REV	DESCRIPTION	DATE	APPROVED

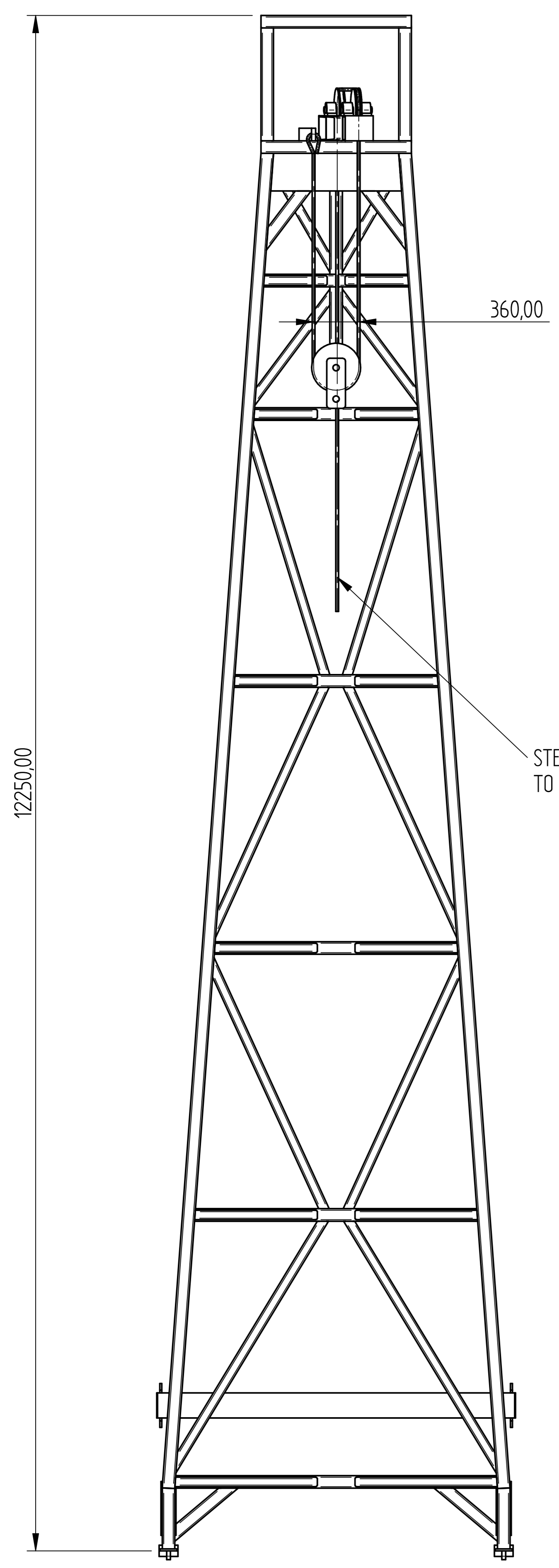

FRONT VIEW

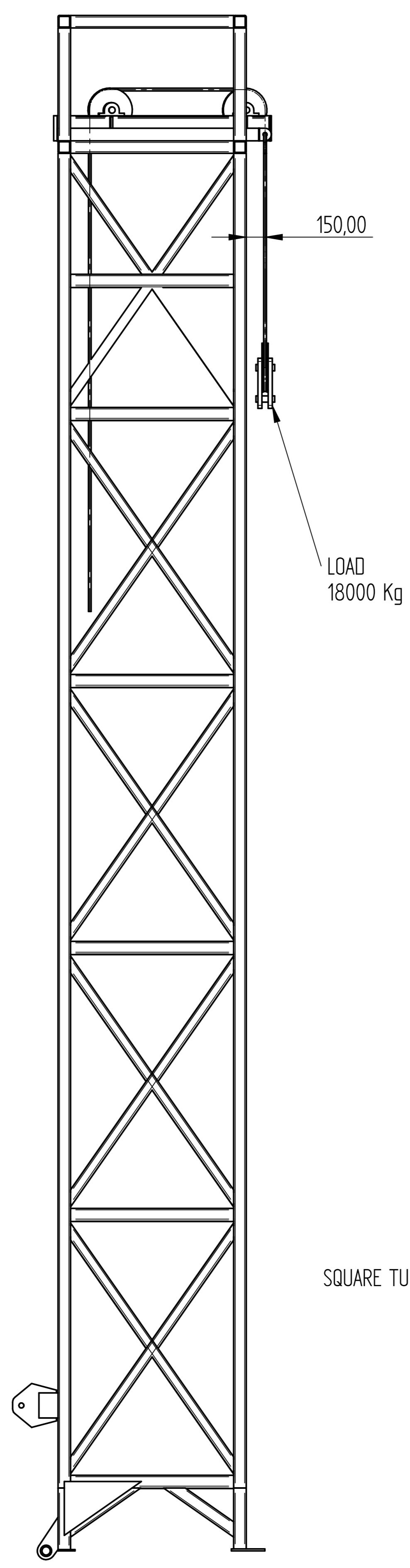

SIDE VIEW

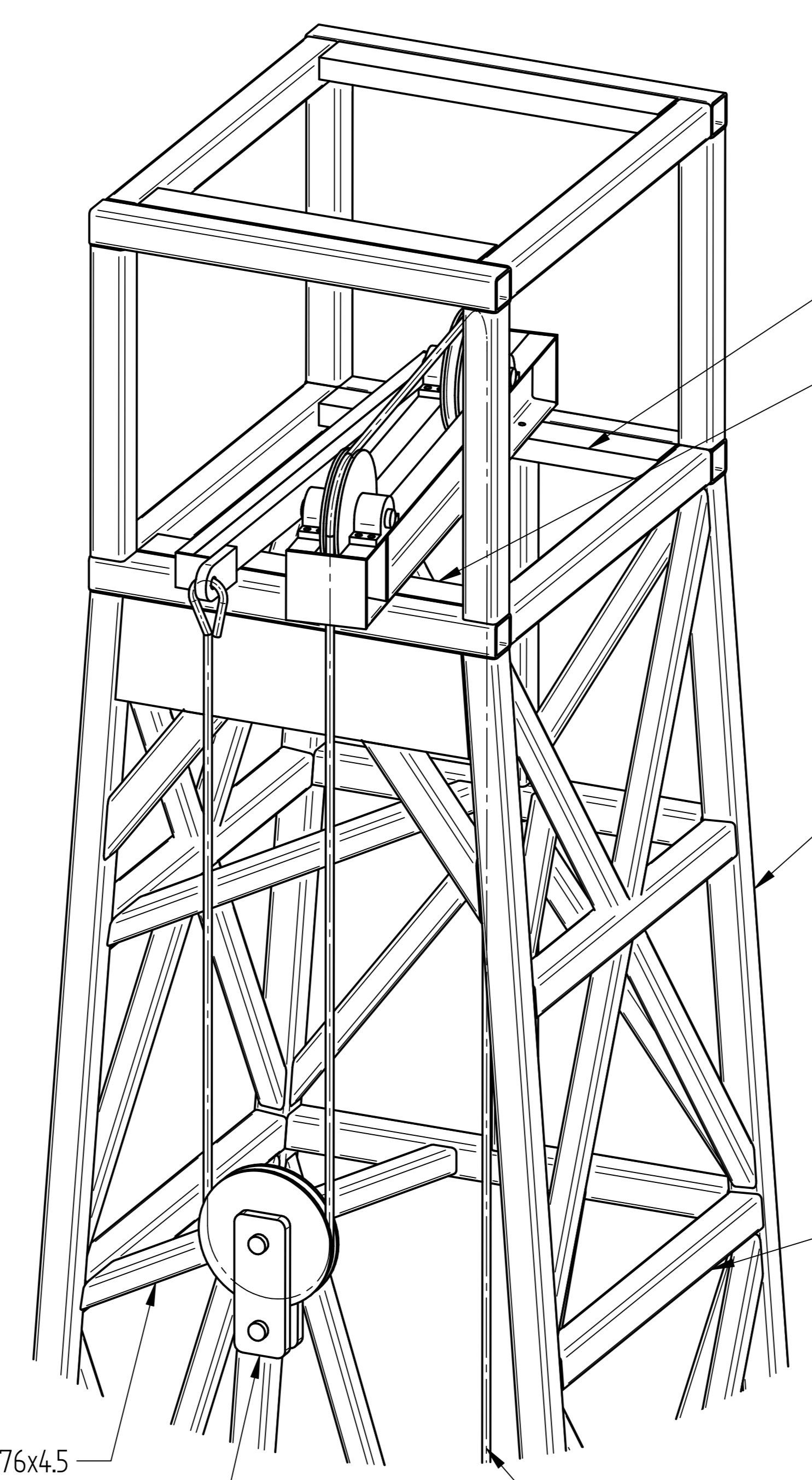

DETAIL A

- SQUARE TUBING 100x100x8
- C-Channel 127x64
- C-Channel 127x64
- SQUARE TUBING 76x76x4.5
- SQUARE TUBING 76x76x4.5
- SQUARE TUBING 100x100x8
- SQUARE TUBING 100x100x8
- SQUARE TUBING 100x100x8
- SQUARE TUBING 100x100x8
- LOAD 18000 Kg
- STEEL ROPE DIA 22mm

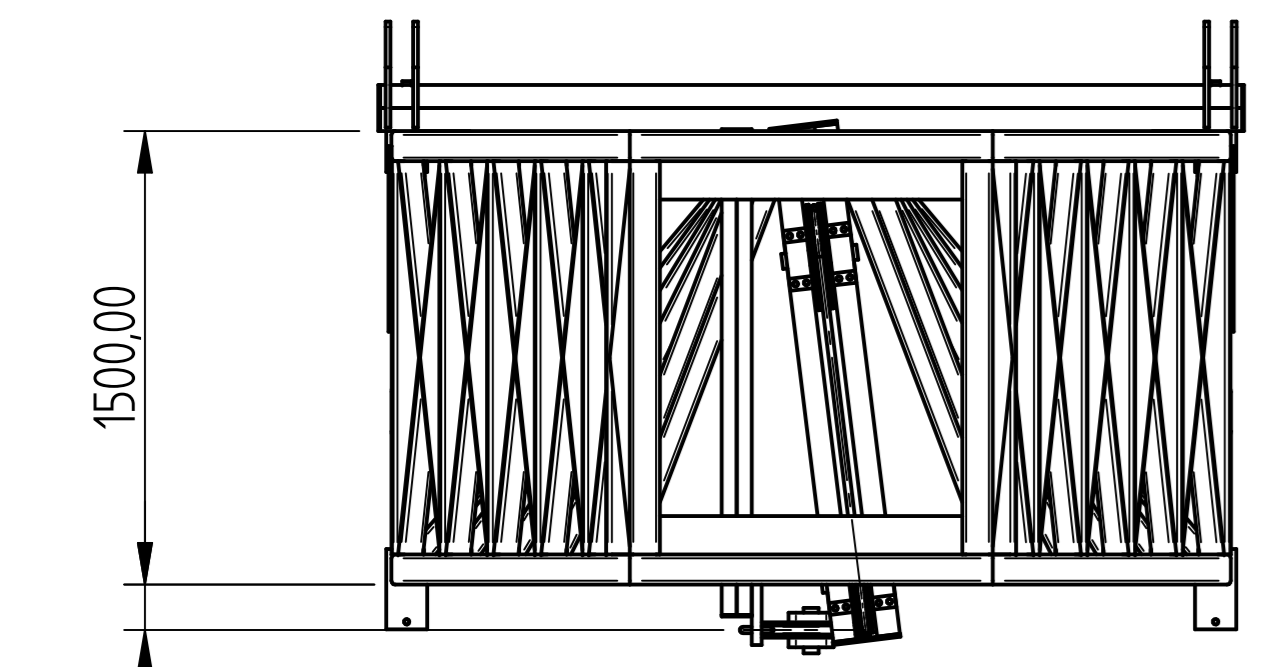
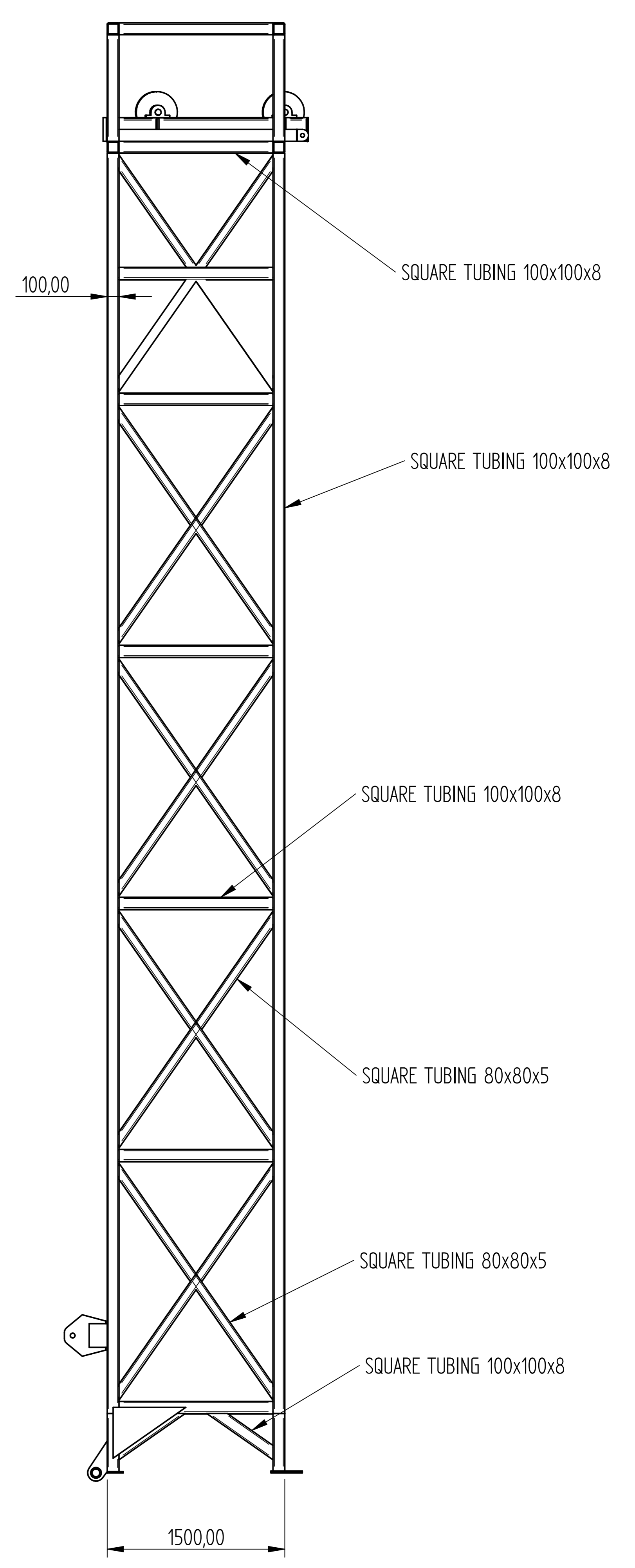
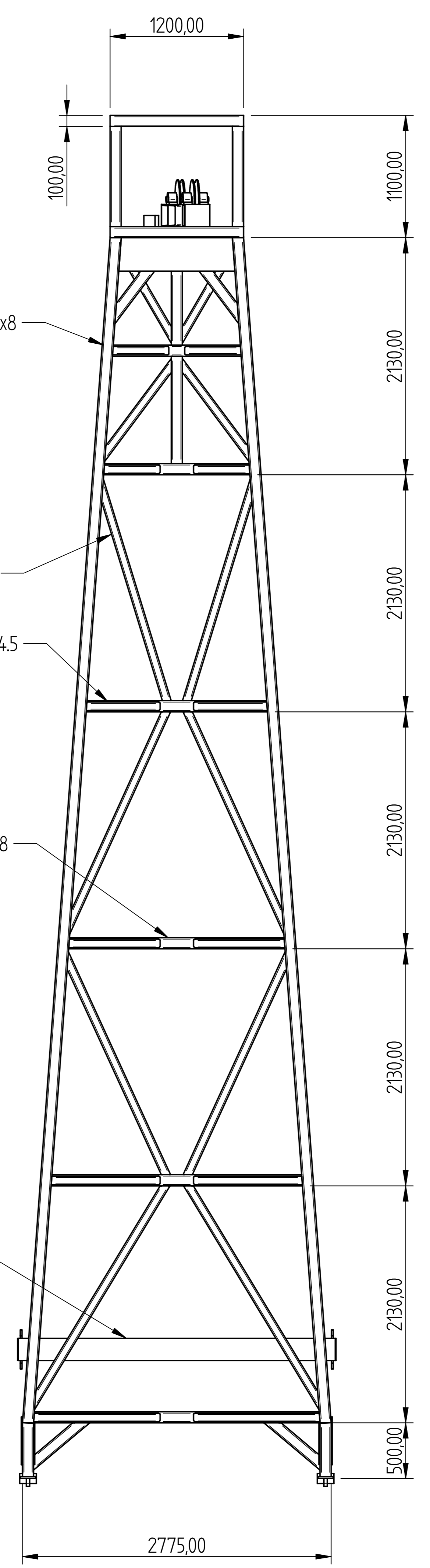

TOP VIEW

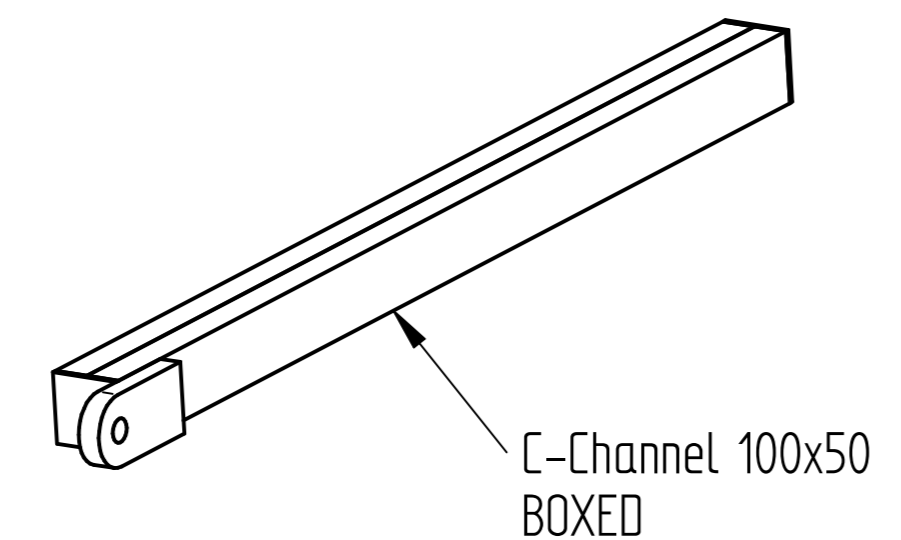

DEAD MAN ARM

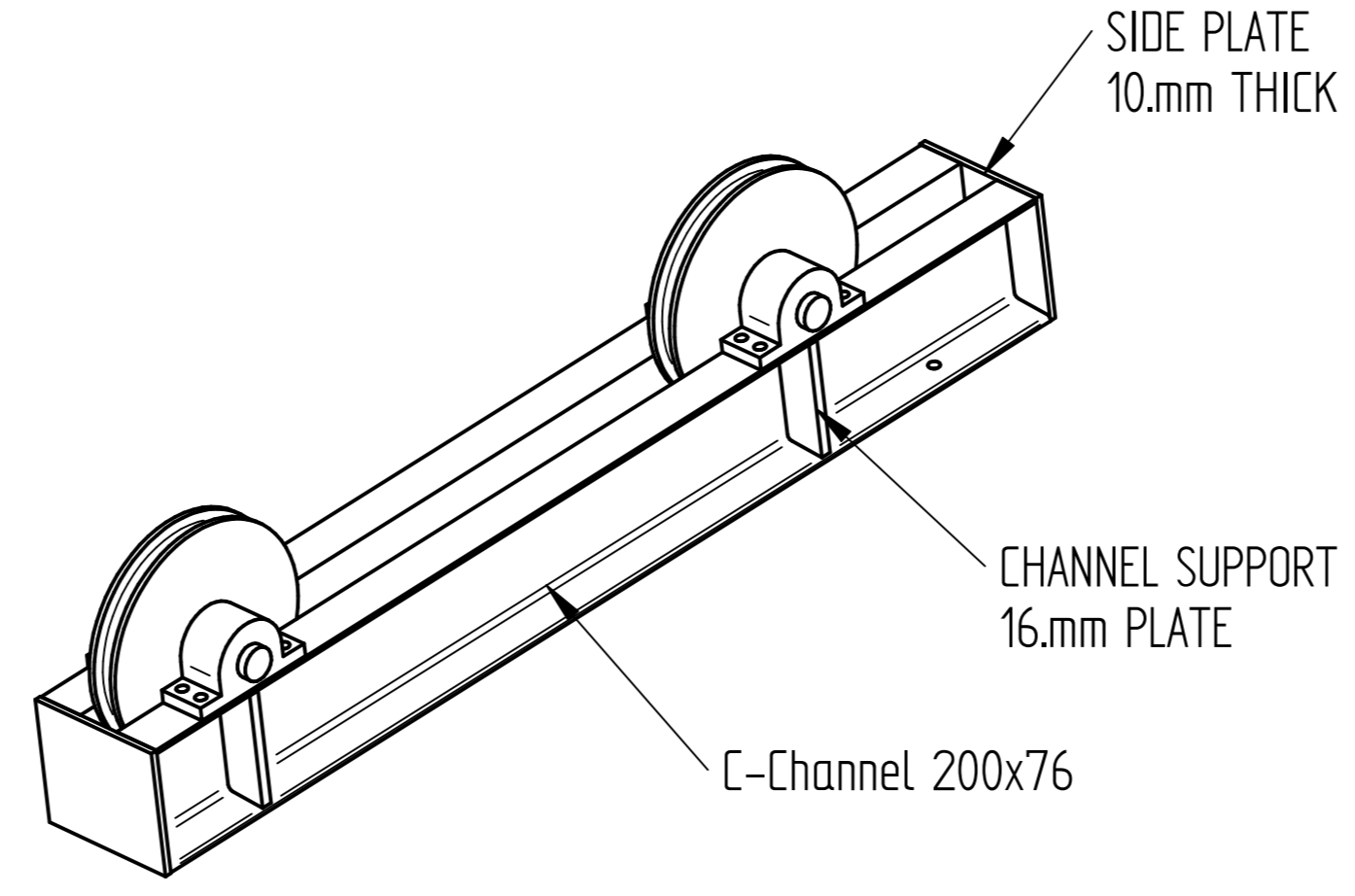

SHEAVE WHEEL BRACKET

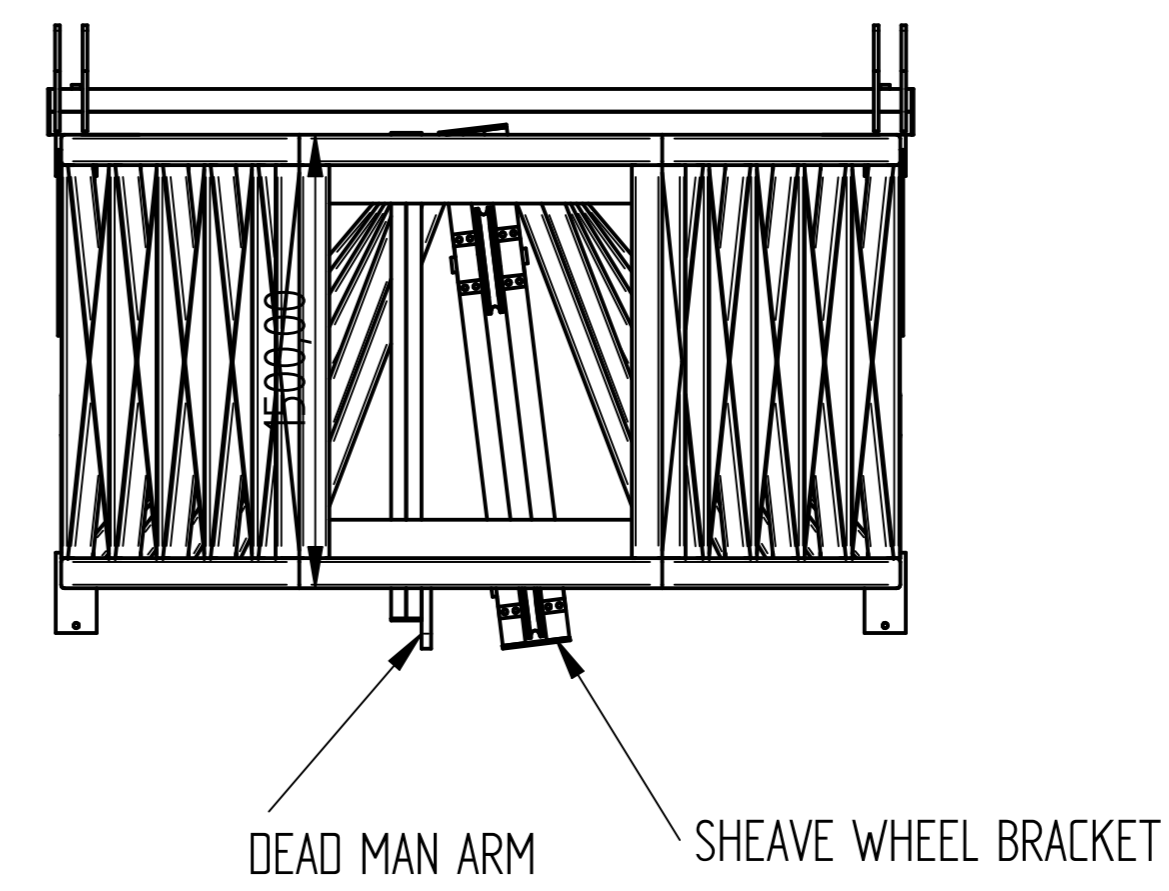

DEAD MAN ARM SHEAVE WHEEL BRACKET

MATERIAL: SABS 1431 GRADE S355JR
ALL WELDING 10mm FILLET

NAME	DATE	EQUAL CHANCE TRADING 50	
DRAWN	DLG	02/06/13	TITLE
APPROVED			2800 DERRICK FRAME
MATERIAL			REV A
TREATMENT			SCALE
UNLESS OTHERWISE SPECIFIED DIMENSIONS ARE IN MILLIMETERS		SIZE	DWG NO
ANGLES ±0.1°		A0	2800-D-000
2 PL ±0.02 3 PL ±0.005		FILE NAME	2800 Derrick Frame.dwg
		SCALE	WEIGHT
			SHEET 2 OF 3