

REVISION HISTORY			
REV	DESCRIPTION	DATE	APPROVED

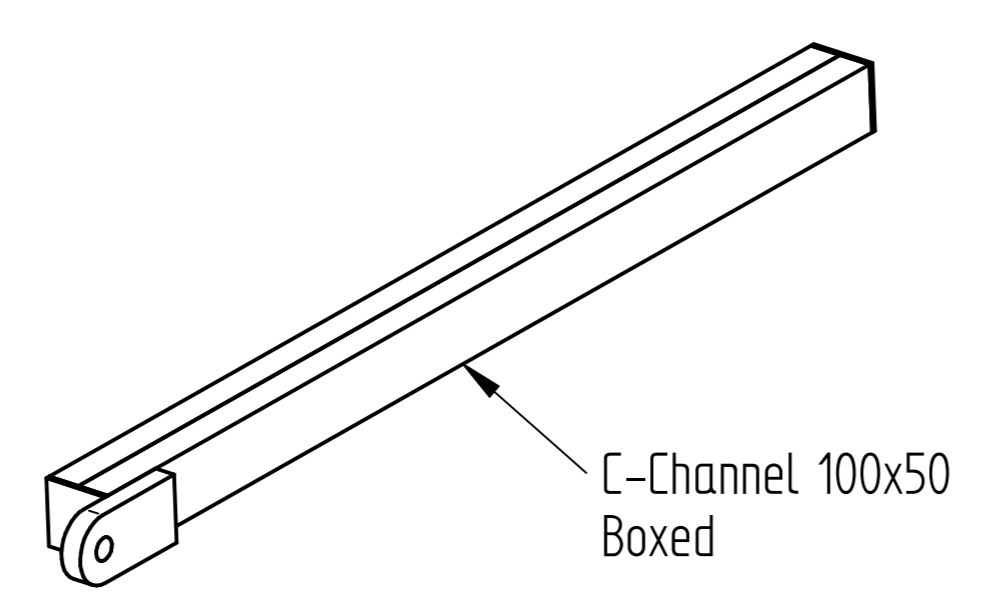

DEAD MAN ARM

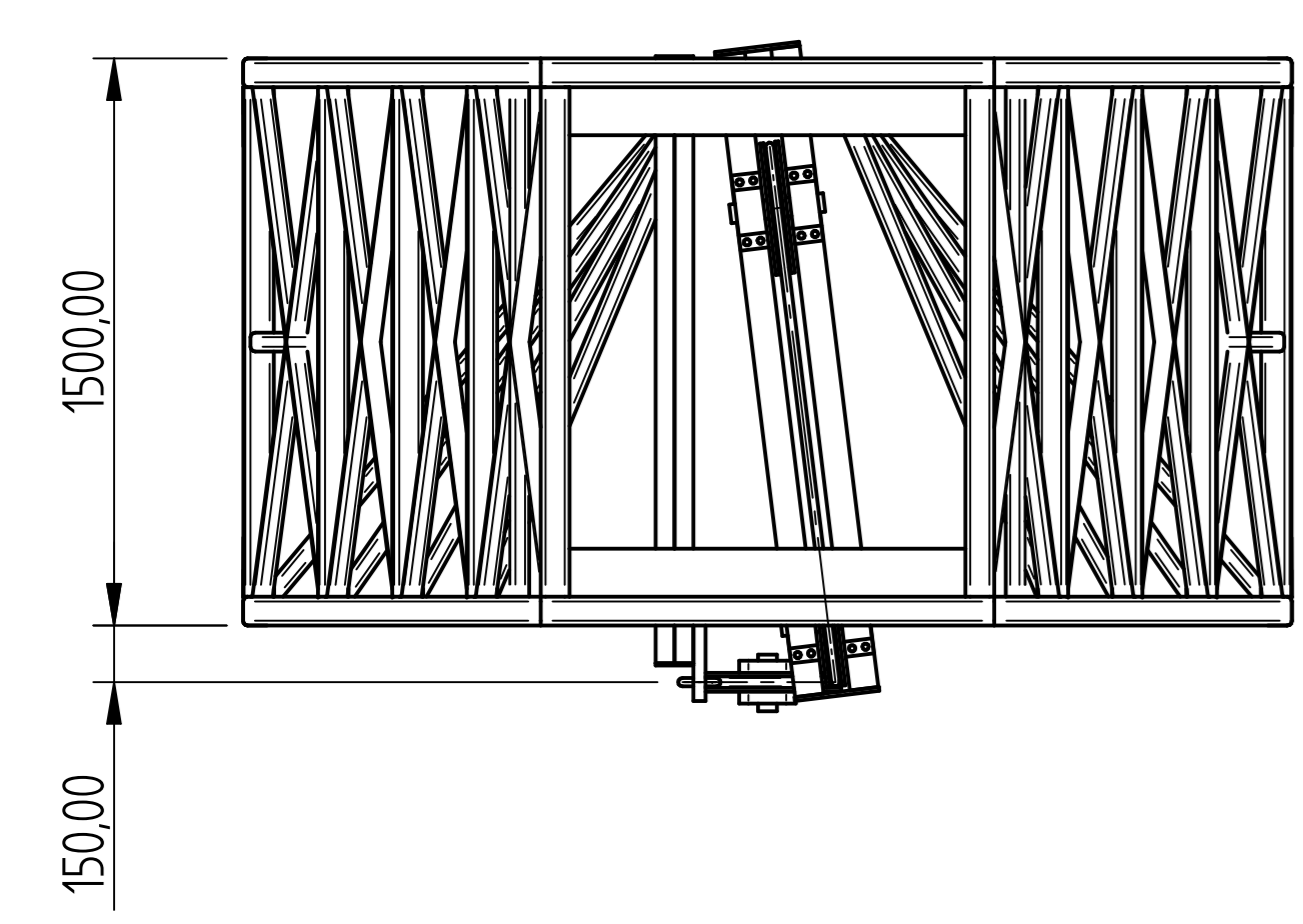
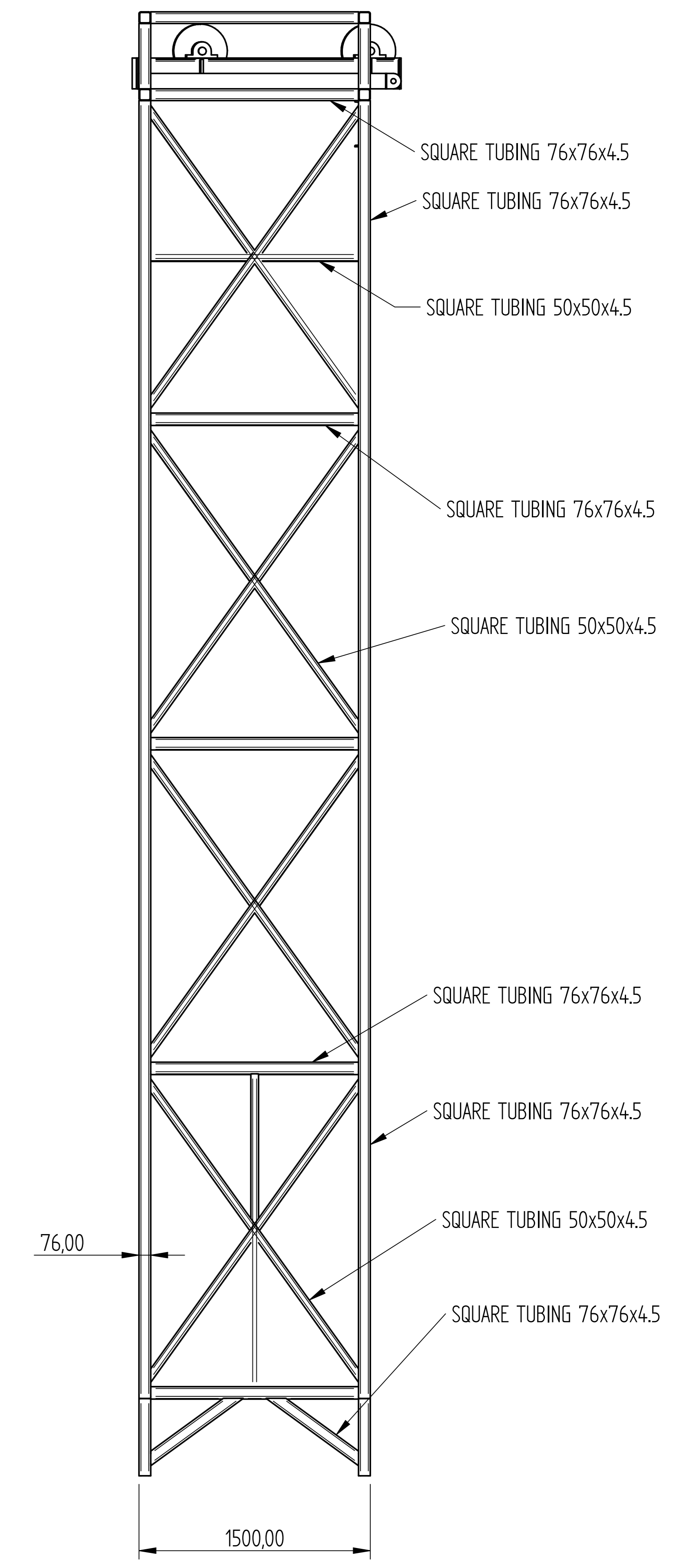
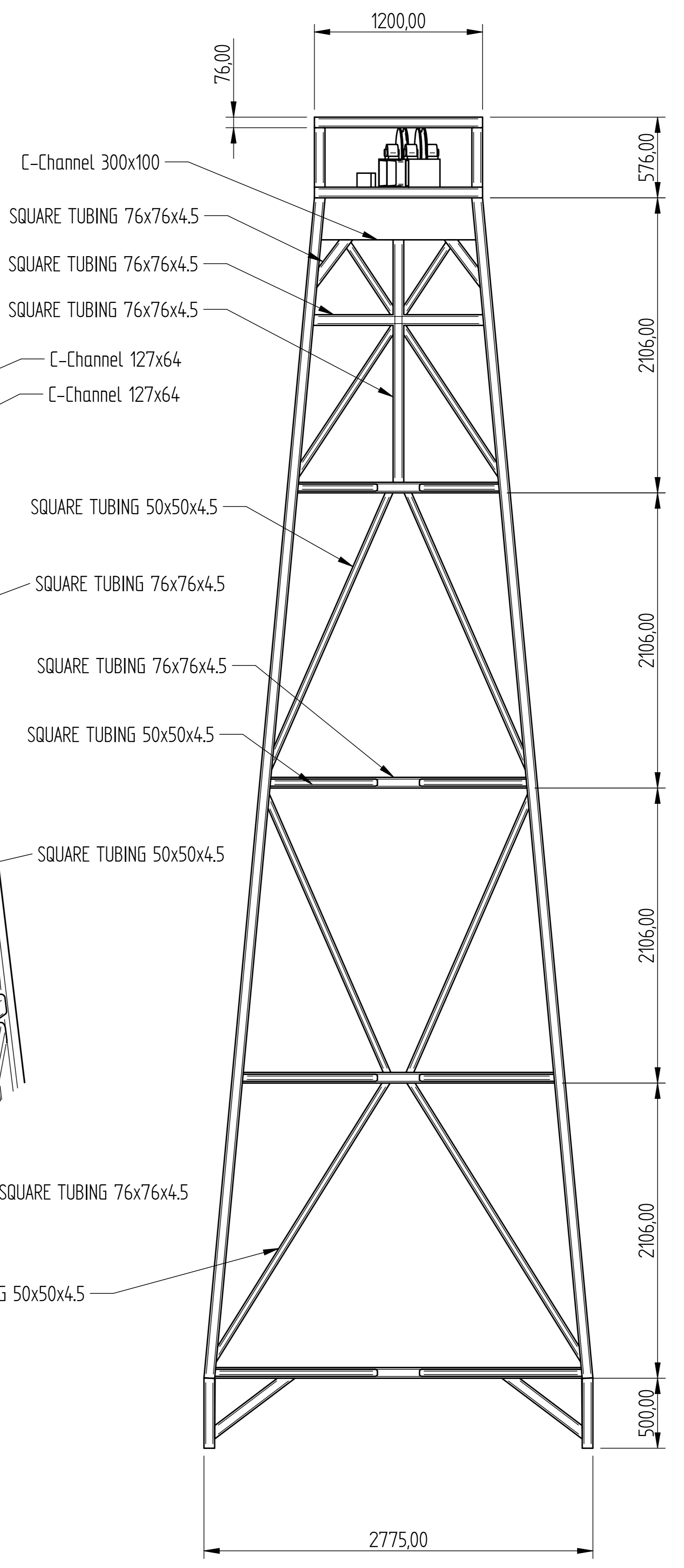
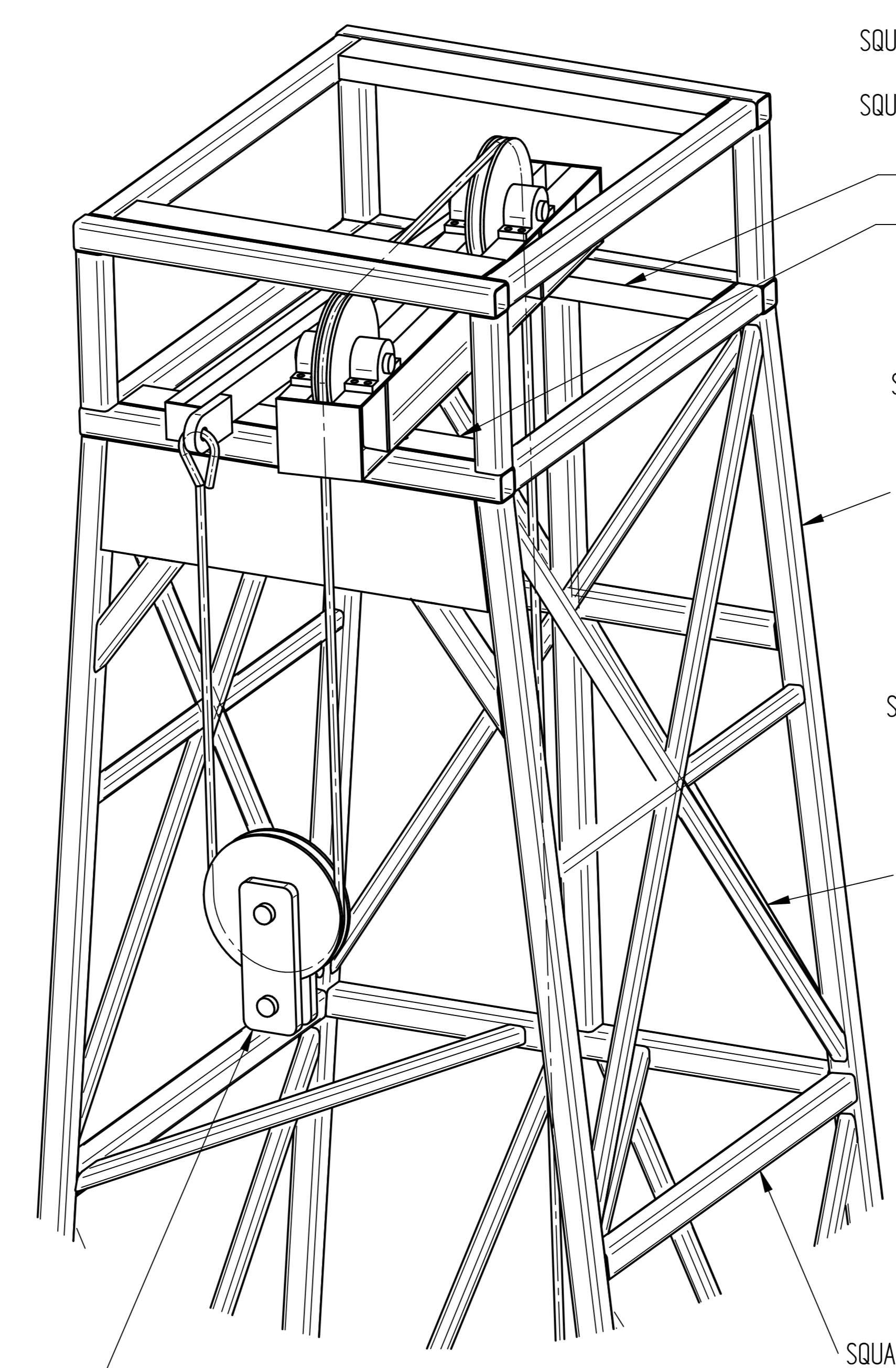
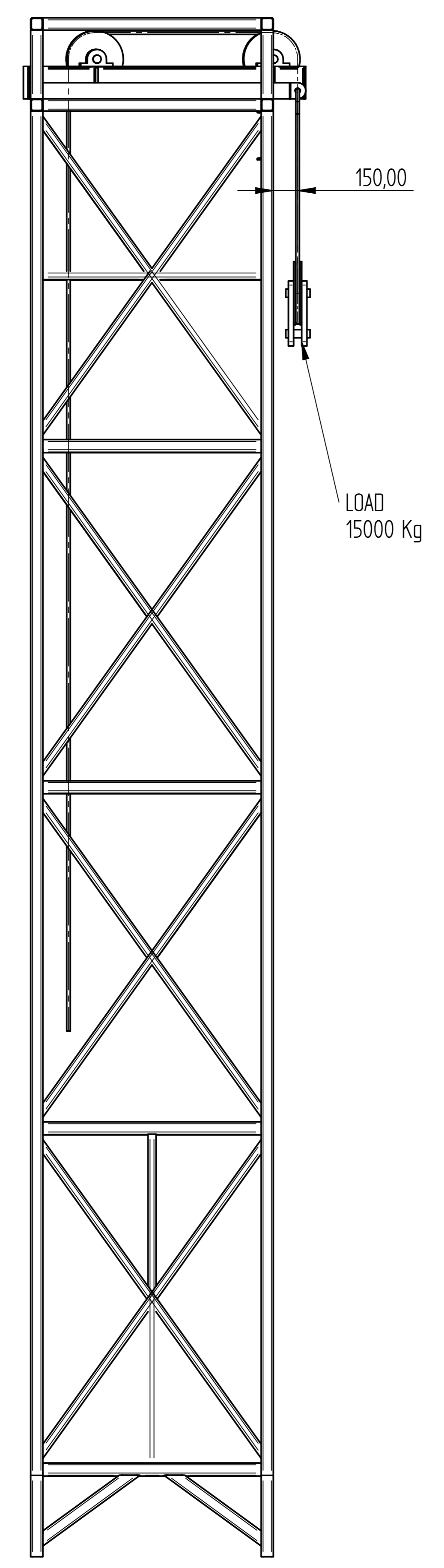
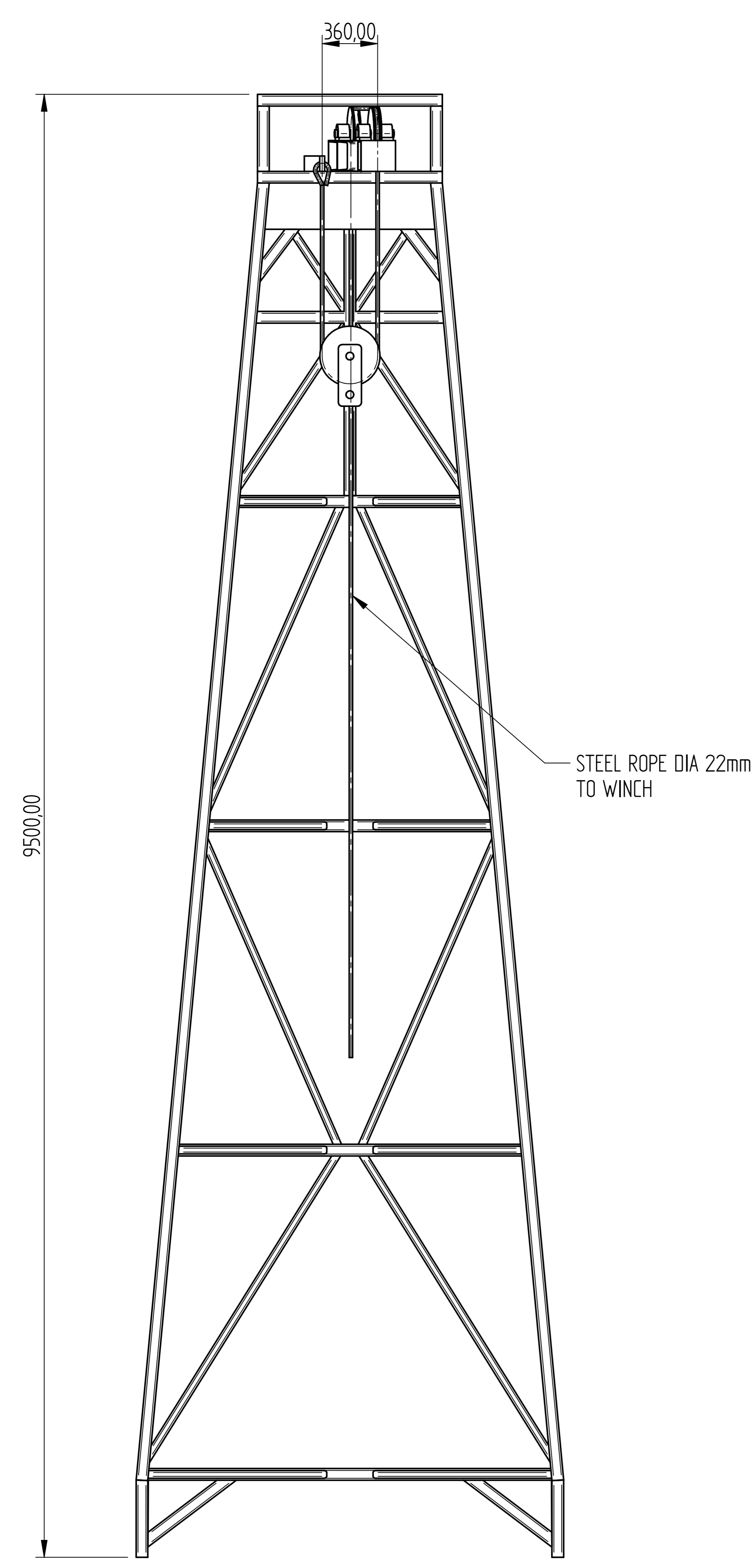
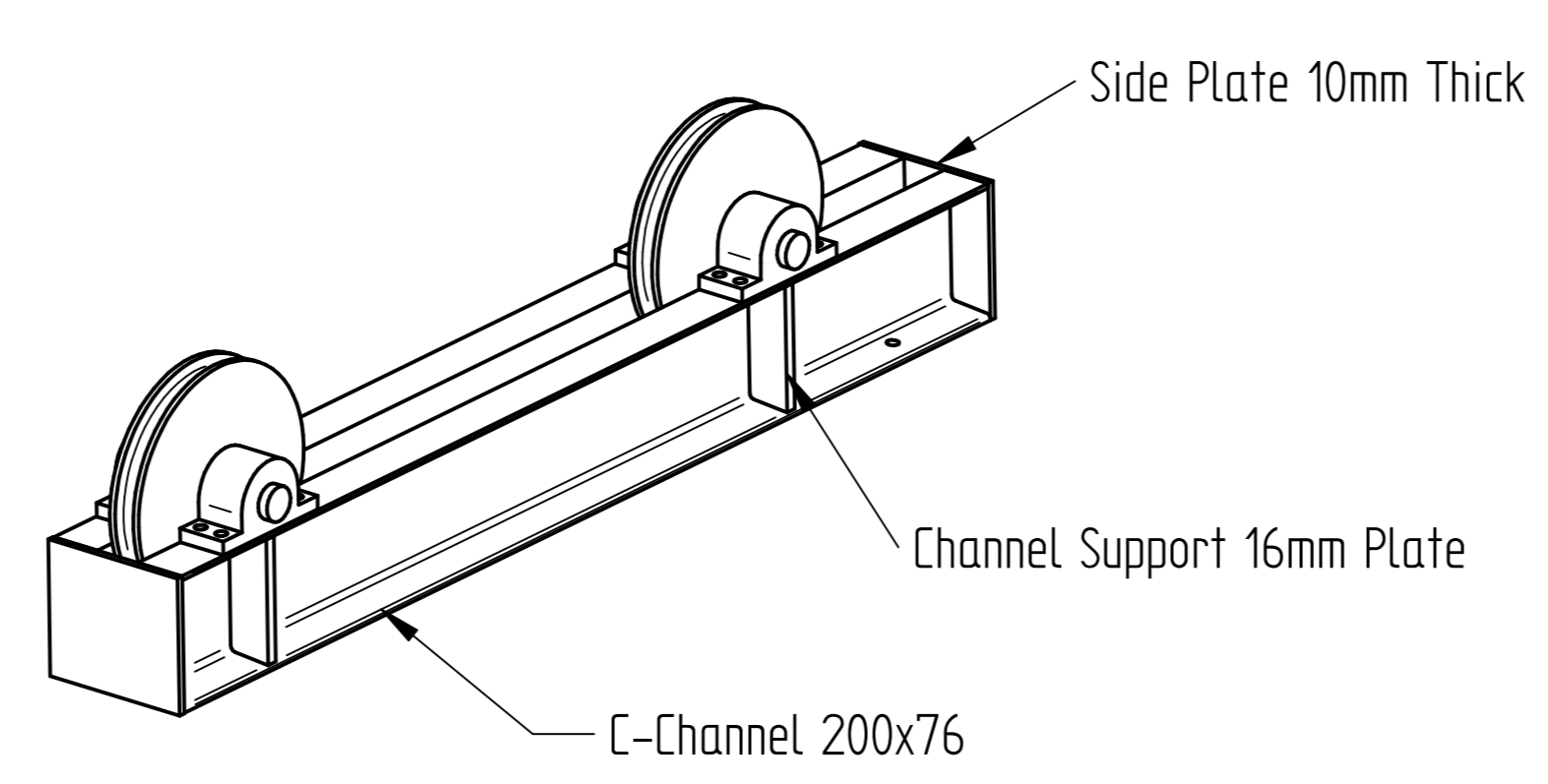

SHEAVE WHEEL BRACKET

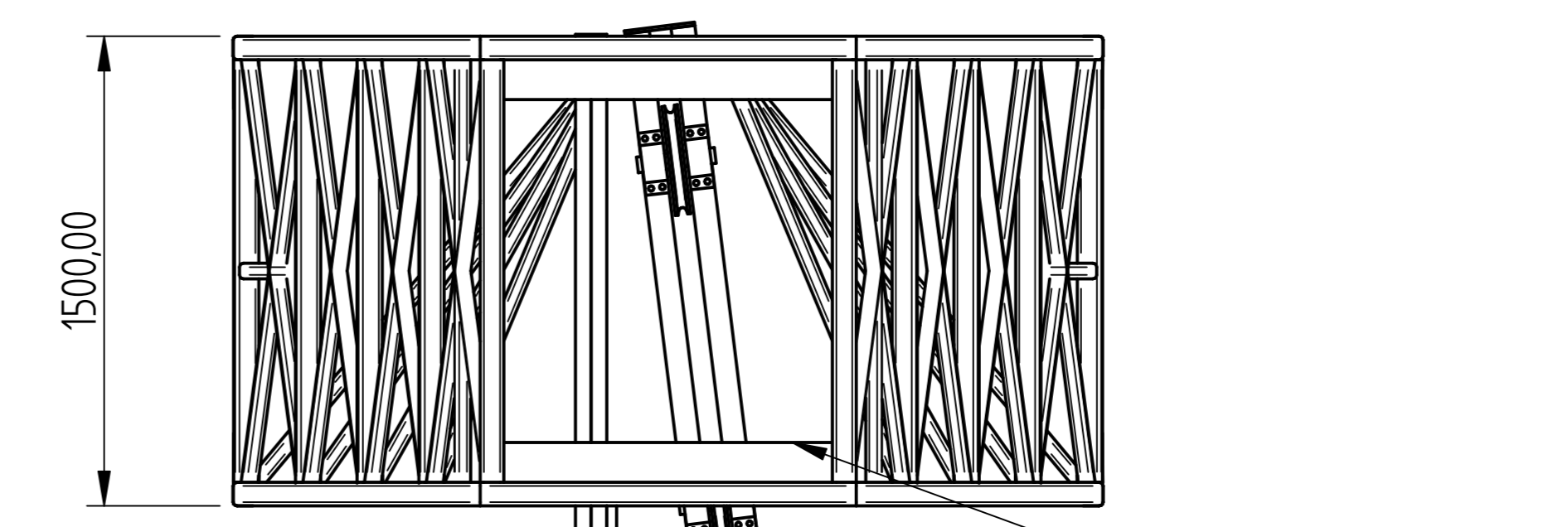

MATERIAL: SABS 1431 GRADE S355JR
ALL WELDING 10mm FILLET

NAME	DATE	TITLE
DRAWN	DLG	05/2011
APPROVED		
MATERIAL		Derrick Frame 2500
TREATMENT		
UNLESS OTHERWISE SPECIFIED DIMENSIONS ARE IN MILLIMETERS		SCALE
ANGLES ±0.1°		WEIGHT
2 PL ±0.02 3 PL ±0.005		SHEET 2 OF 2

EQUAL CHANCE TRADING 50