

REVISION HISTORY			
REV	DESCRIPTION	DATE	APPROVED

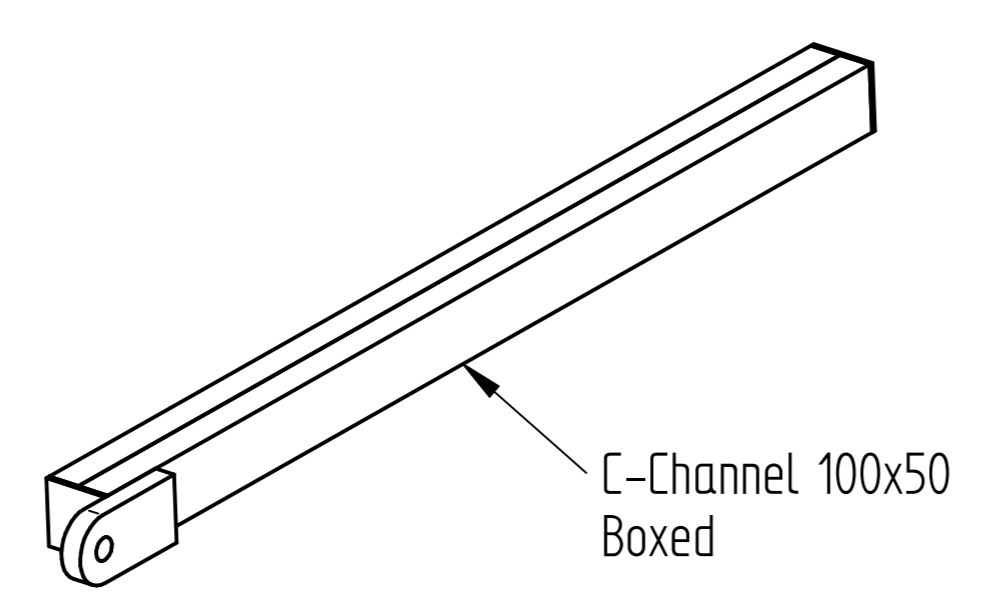

DEAD MAN ARM

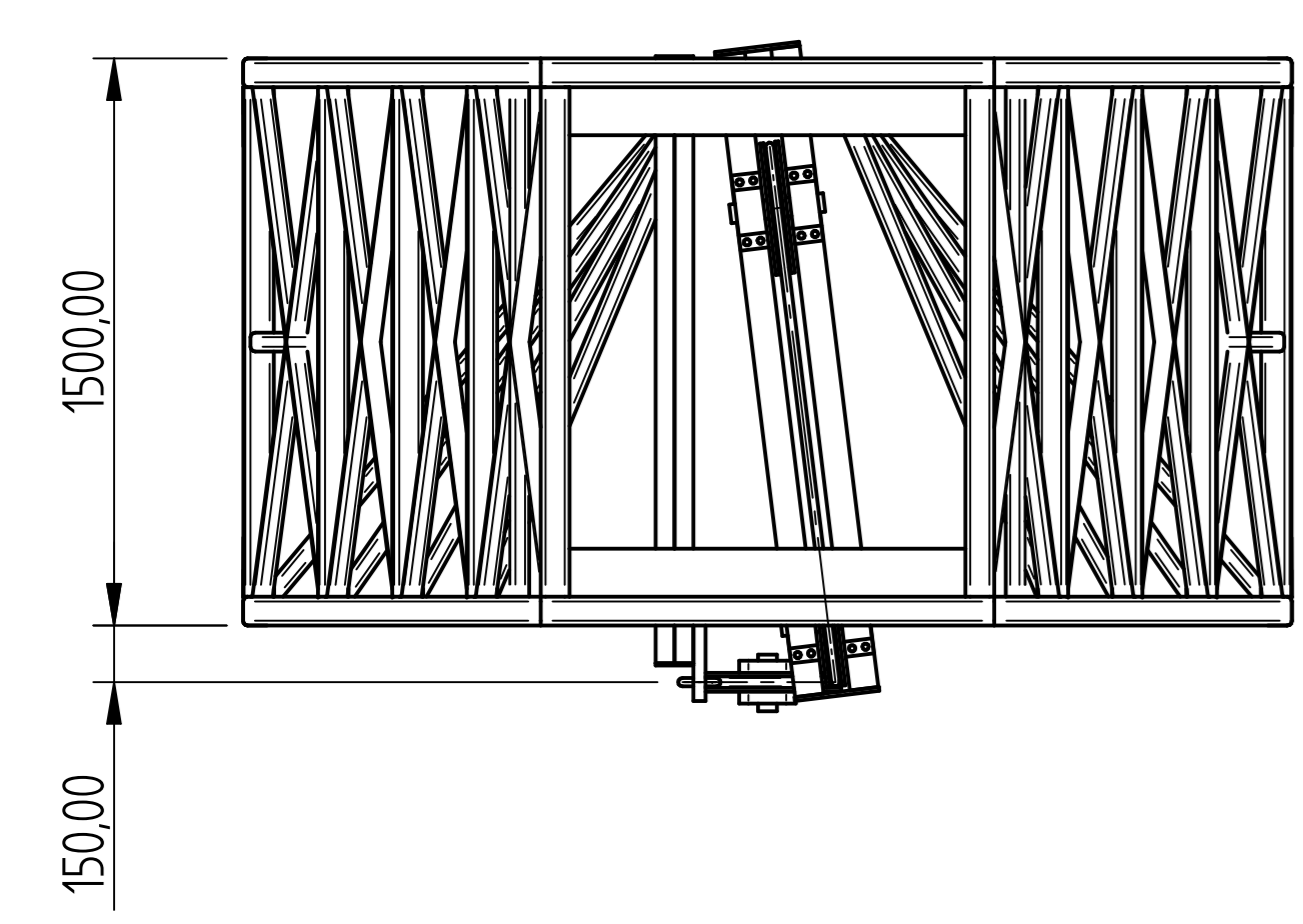
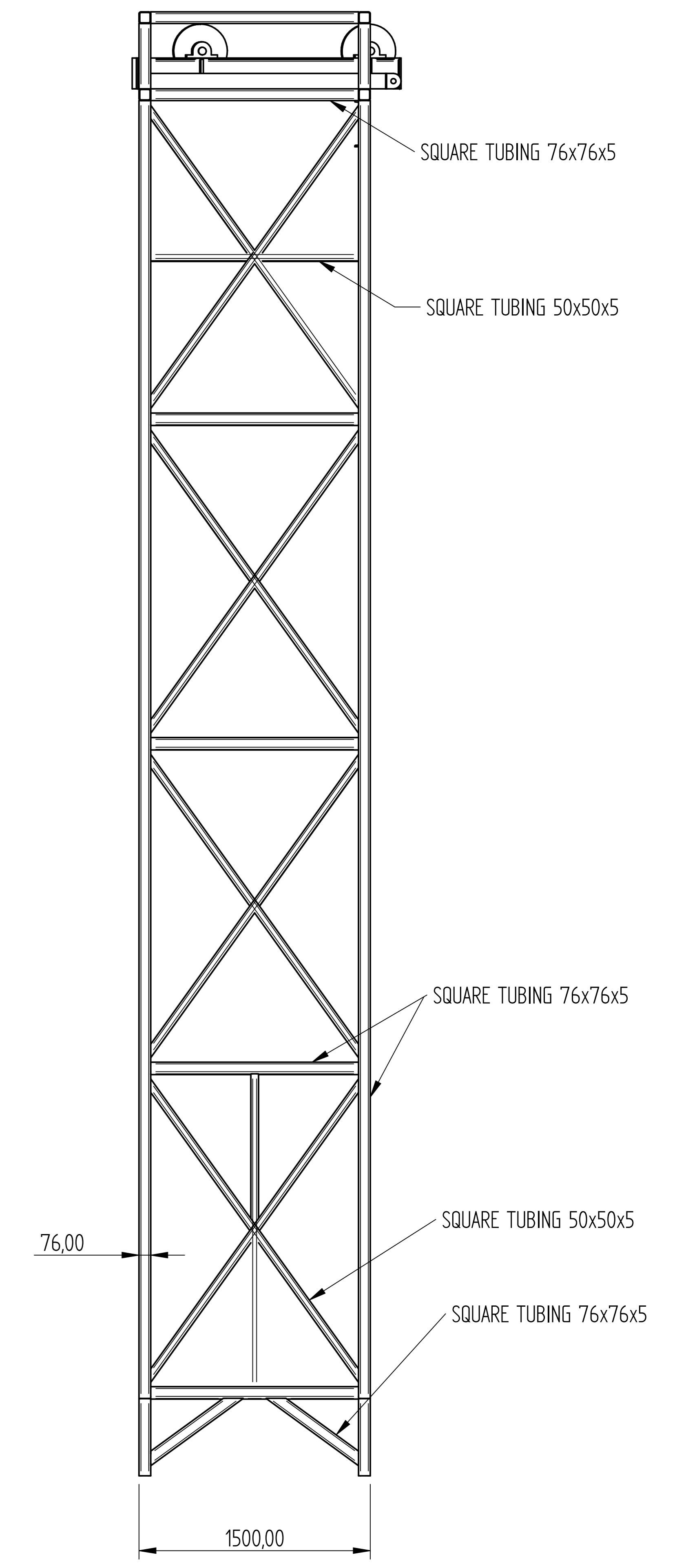
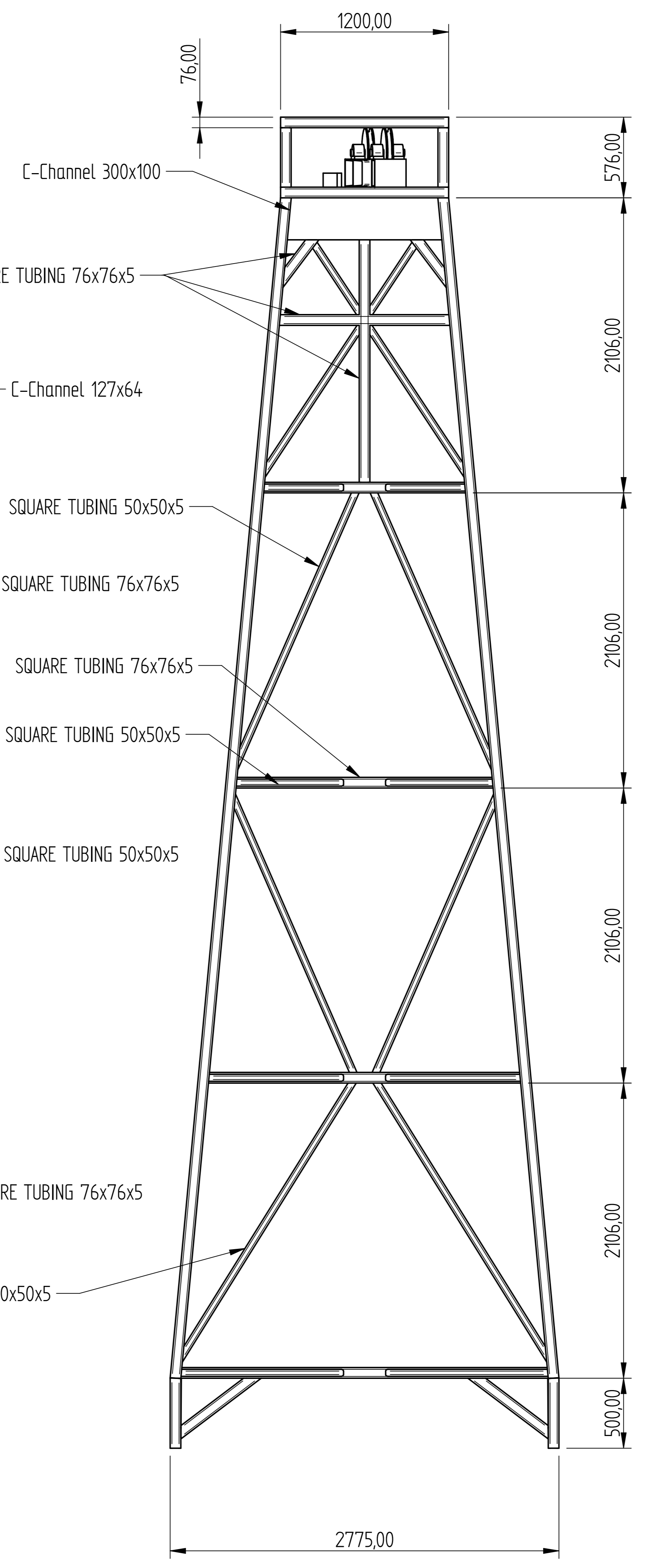
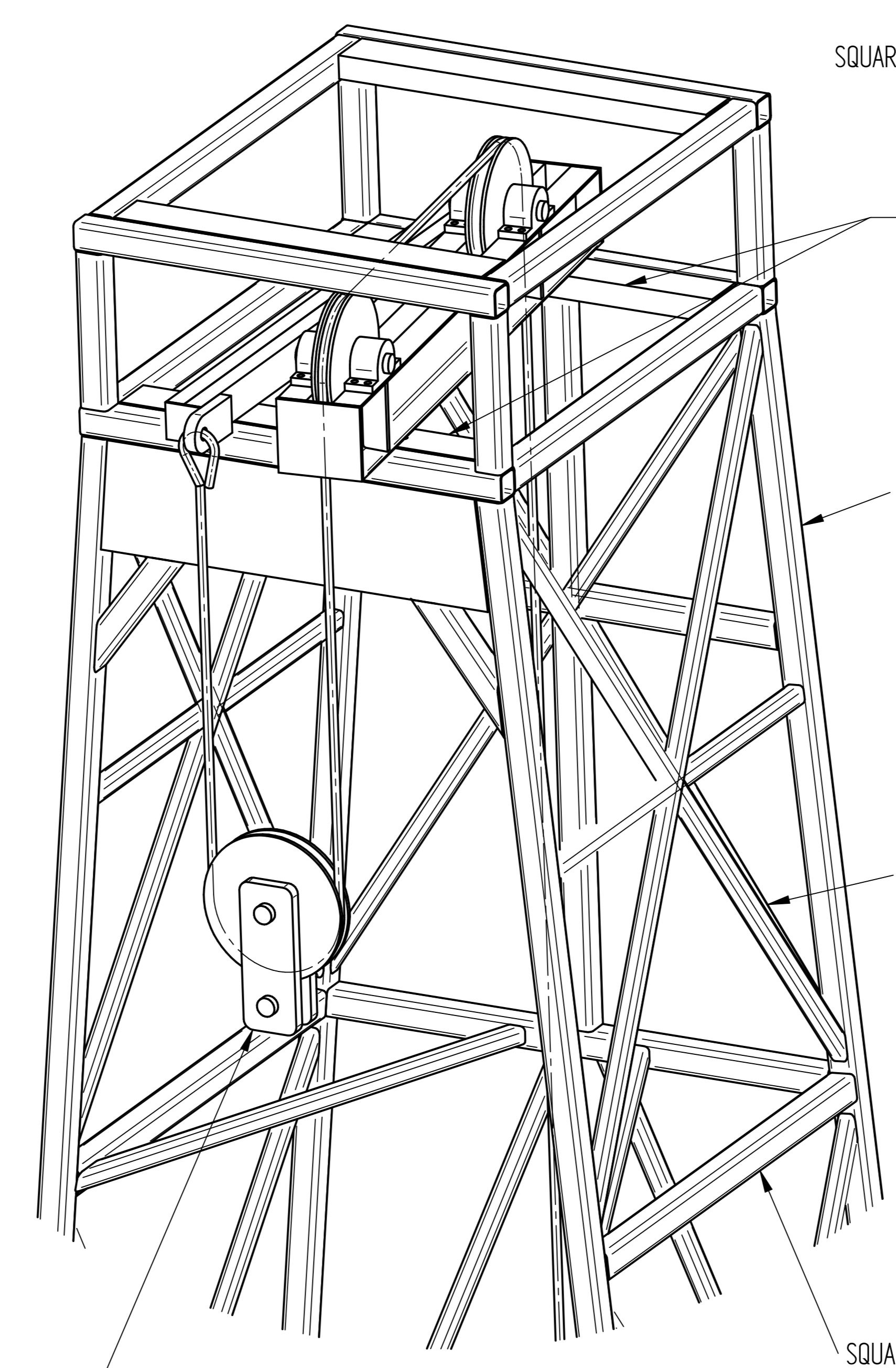
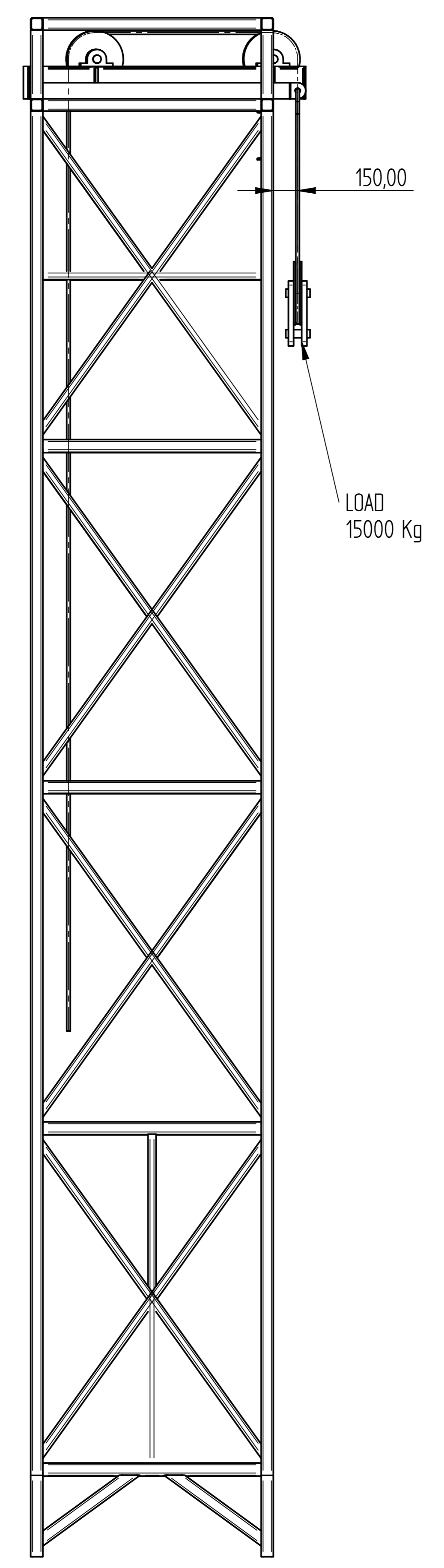
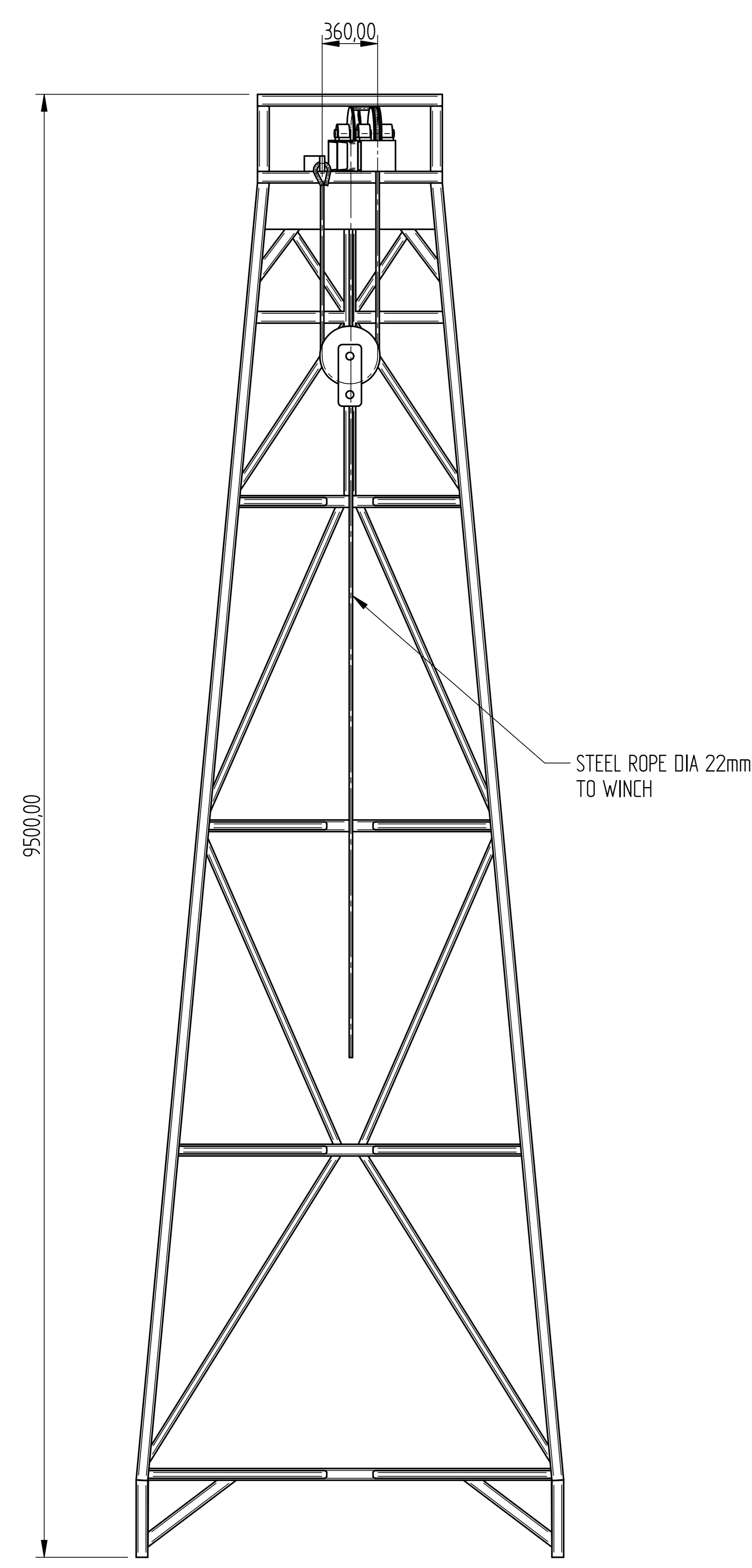
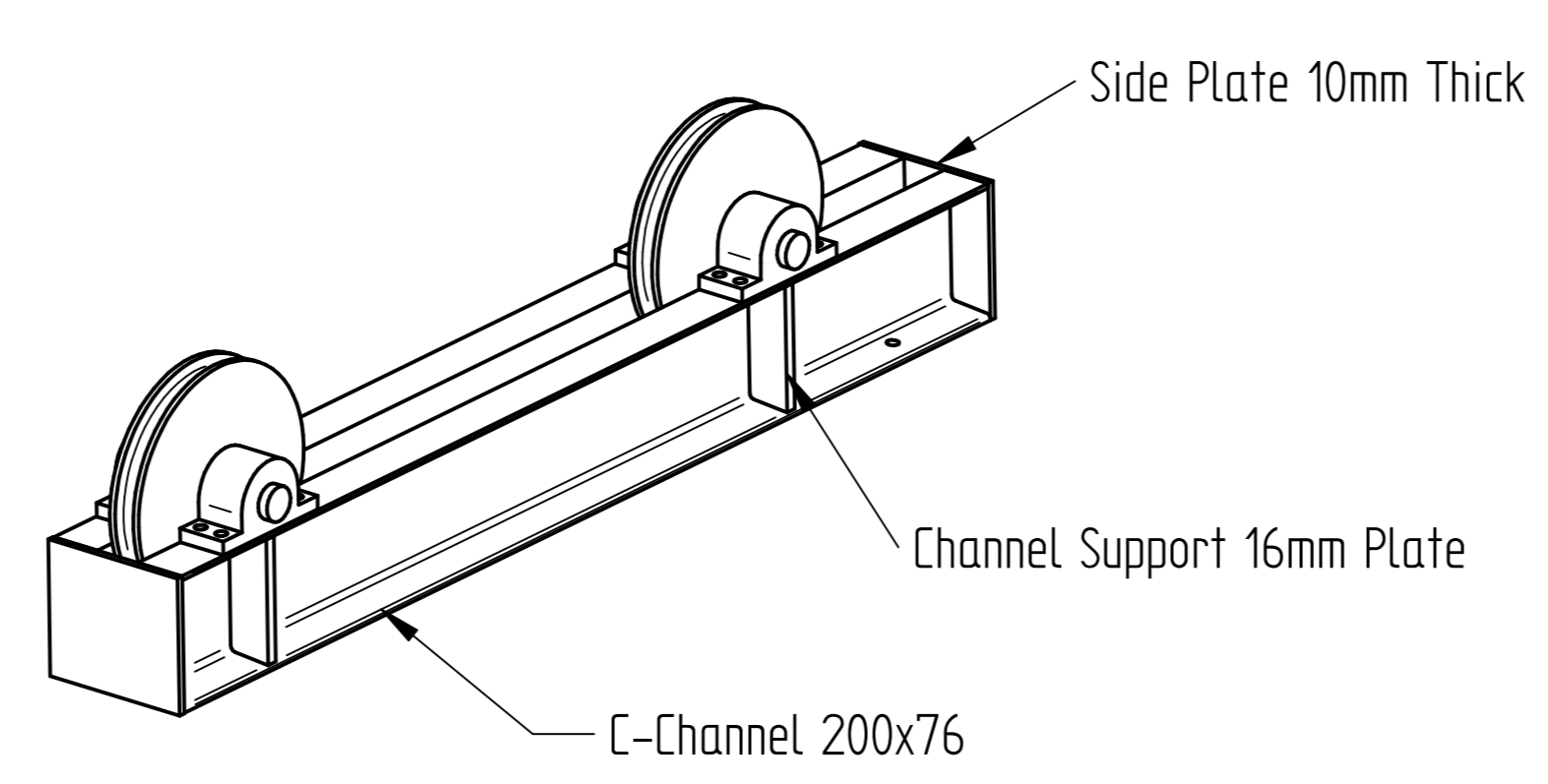

SHEAVE WHEEL BRACKET

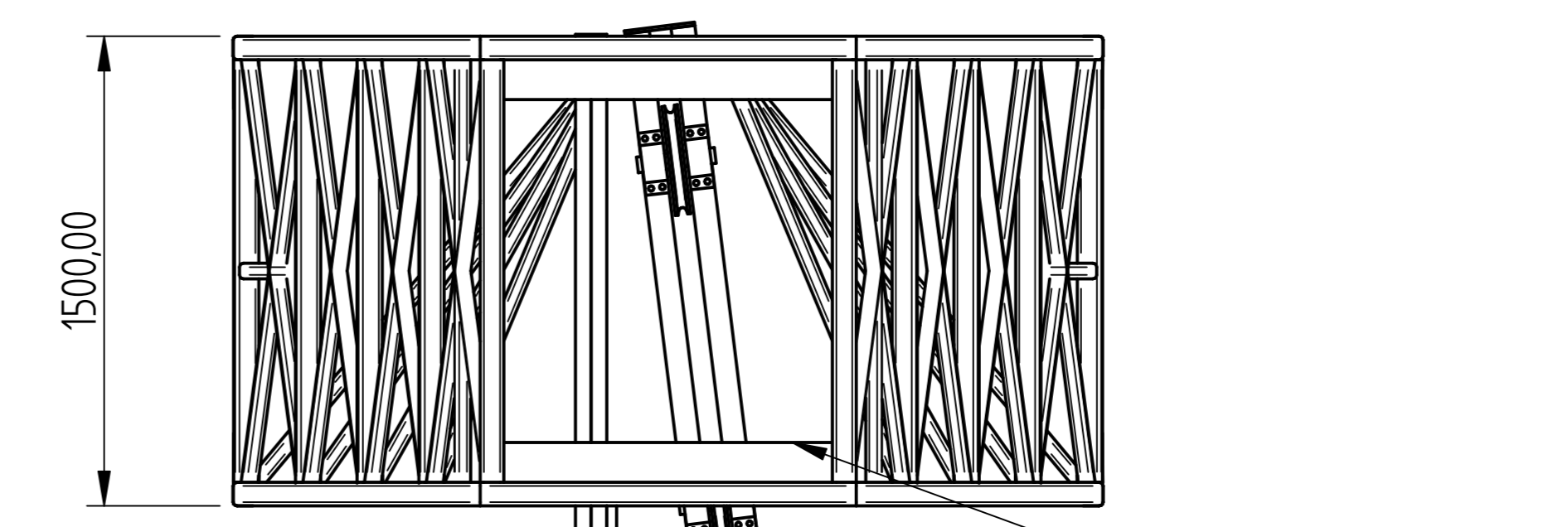

DEAD MAN ARM SHEAVE WHEEL BRACKET

MATERIAL: SABS 1431 GRADE S355JR
ALL WELDING 10mm FILLET

NAME	DATE	EQUAL CHANCE TRADING 50	
DRAWN	DLG	05/2011	TITLE
APPROVED			Derrick Frame 2500
MATERIAL			REV A
TREATMENT			FILE NAME: Derrick Frame 2500.dwg
UNLESS OTHERWISE SPECIFIED DIMENSIONS ARE IN MILLIMETERS		SCALE	WEIGHT
ANGLES ±0.1°		2 PL ±0.02	3 PL ±0.005
SHEET 2 OF 2			