

REVISION HISTORY			
REV	DESCRIPTION	DATE	APPROVED

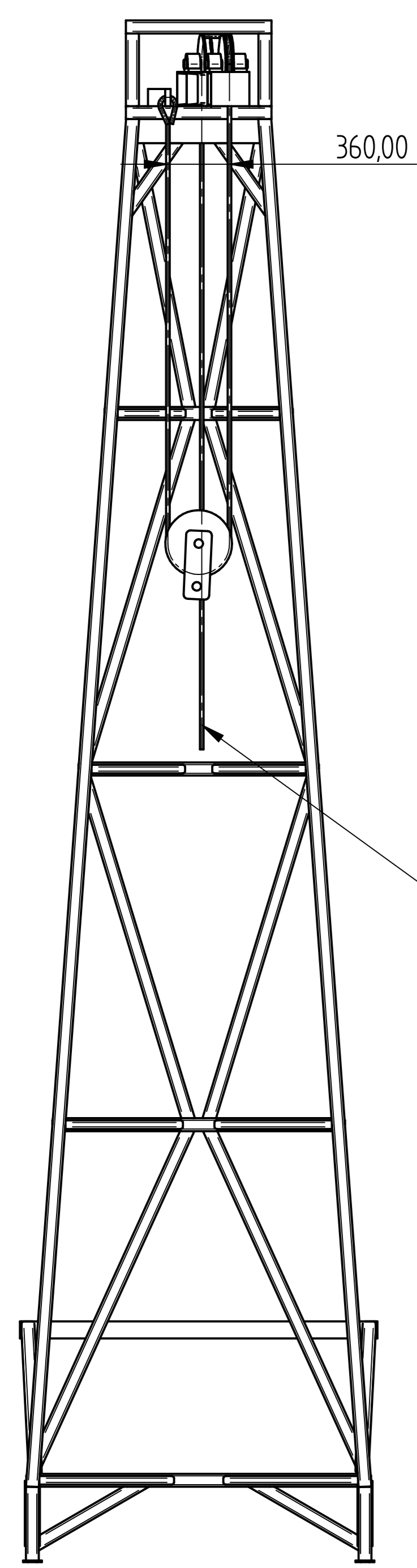

STEEL ROPE TO WINCH

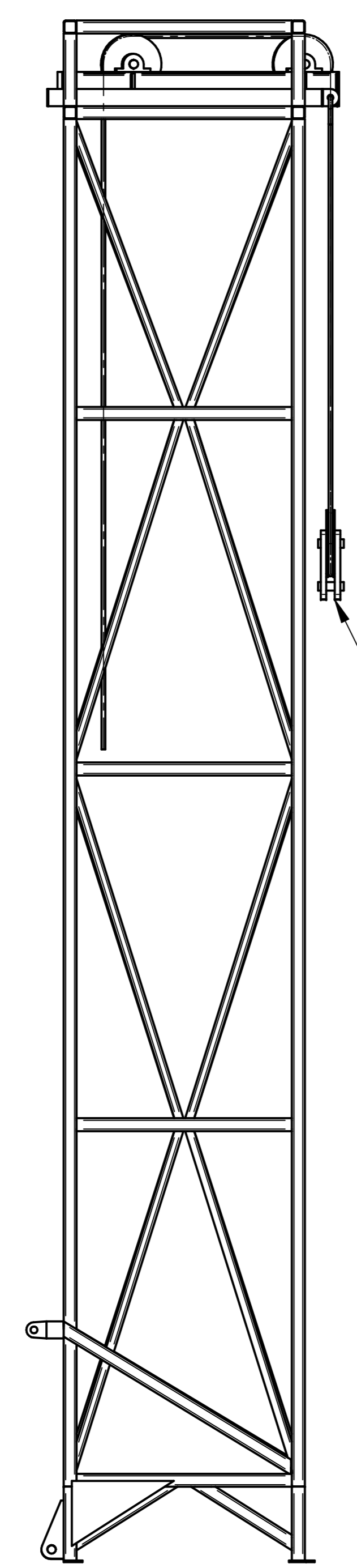

LOAD APPLIED 8650 Kg

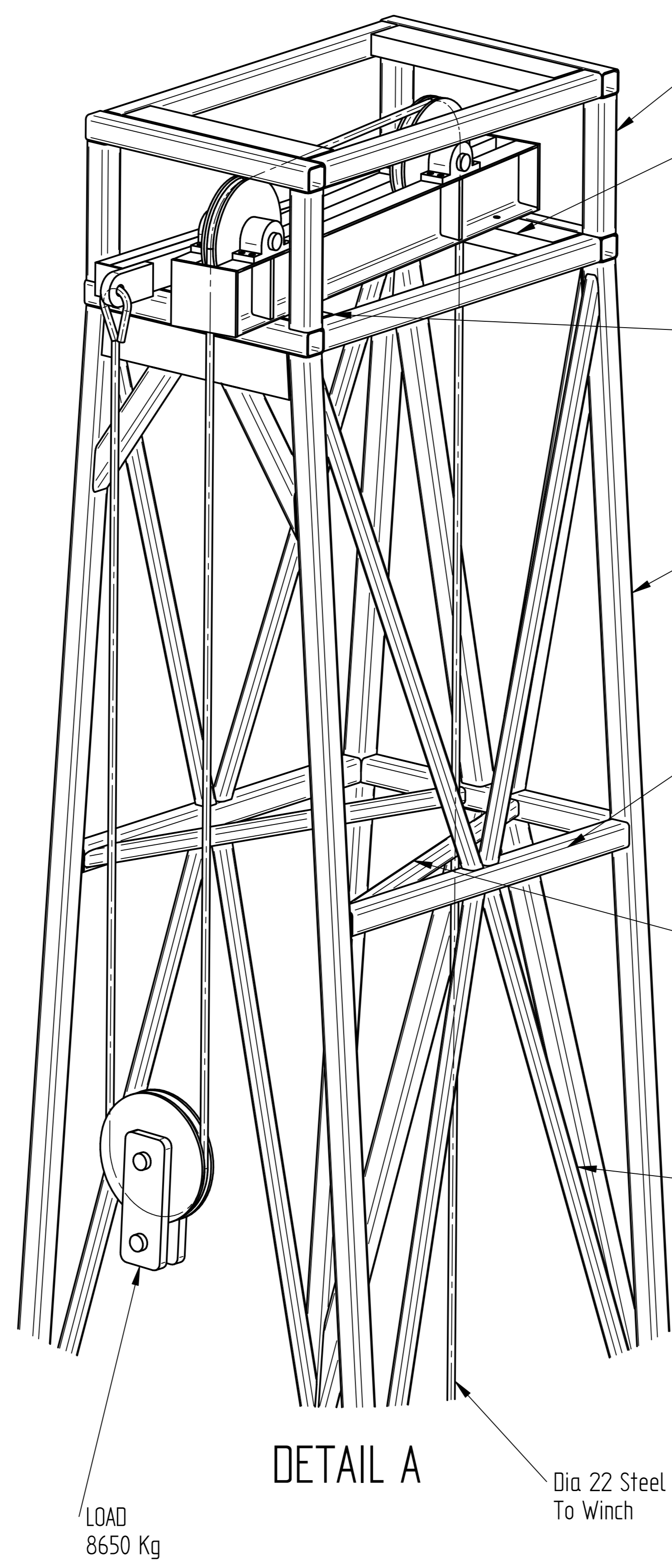

DETAIL A

Dia 22 Steel Rope To Winch

- SQUARE TUBING 80x80x5
- C-Channel 127x64
- C-Channel 127x64
- SQUARE TUBING 80x80x5
- SQUARE TUBING 80x80x5
- SQUARE TUBING 50x50x4.5
- SQUARE TUBING 50x50x4.5

LOAD 8650 Kg

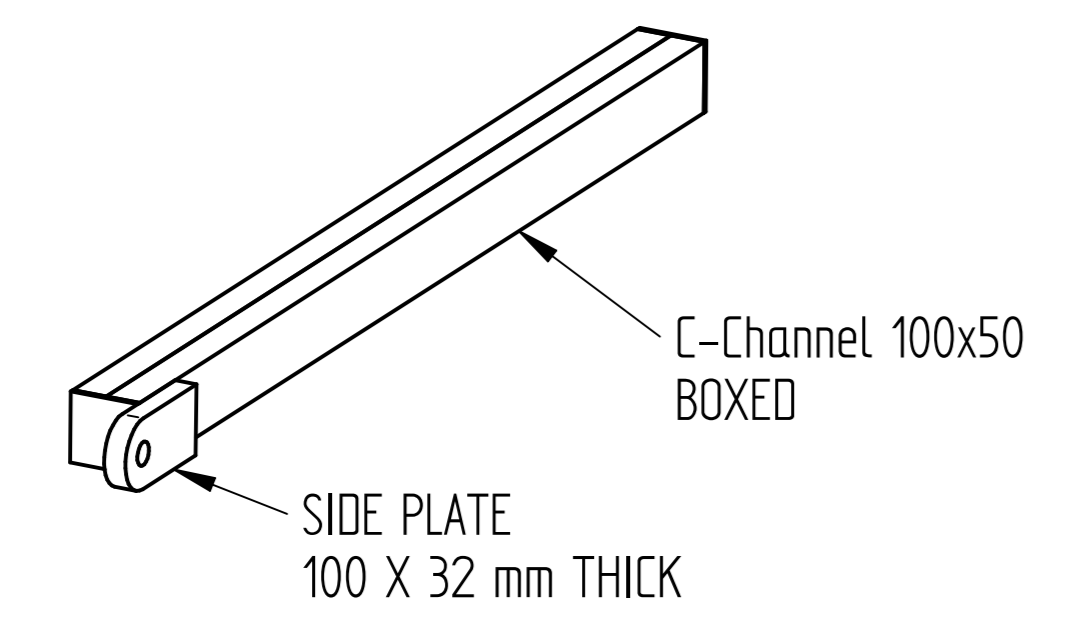
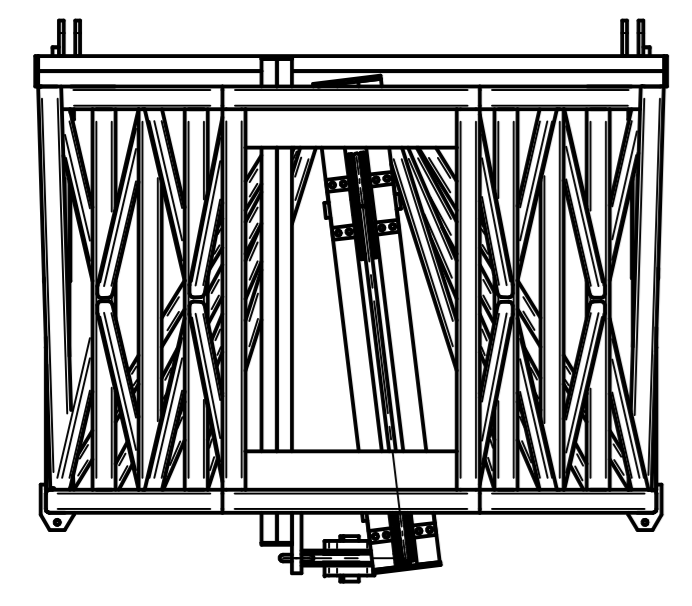
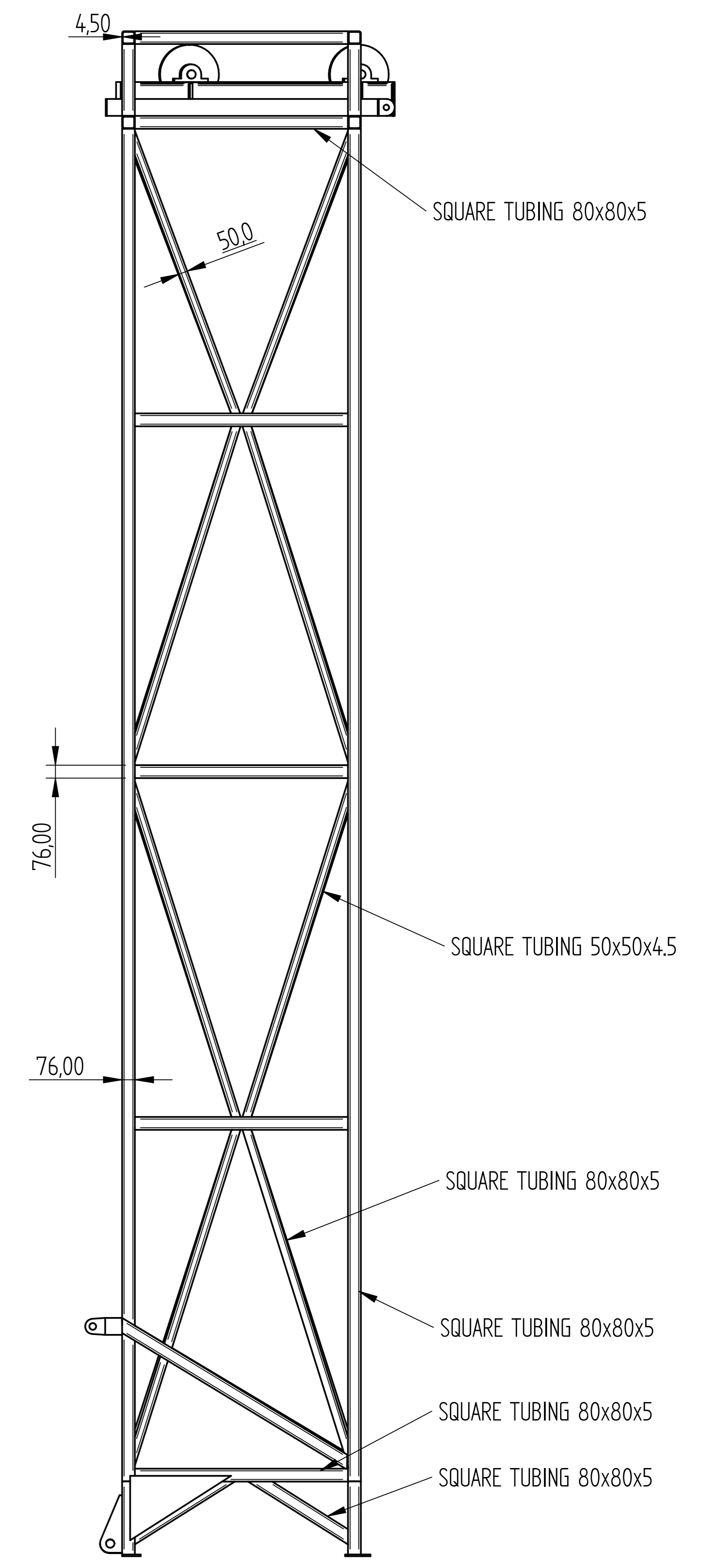
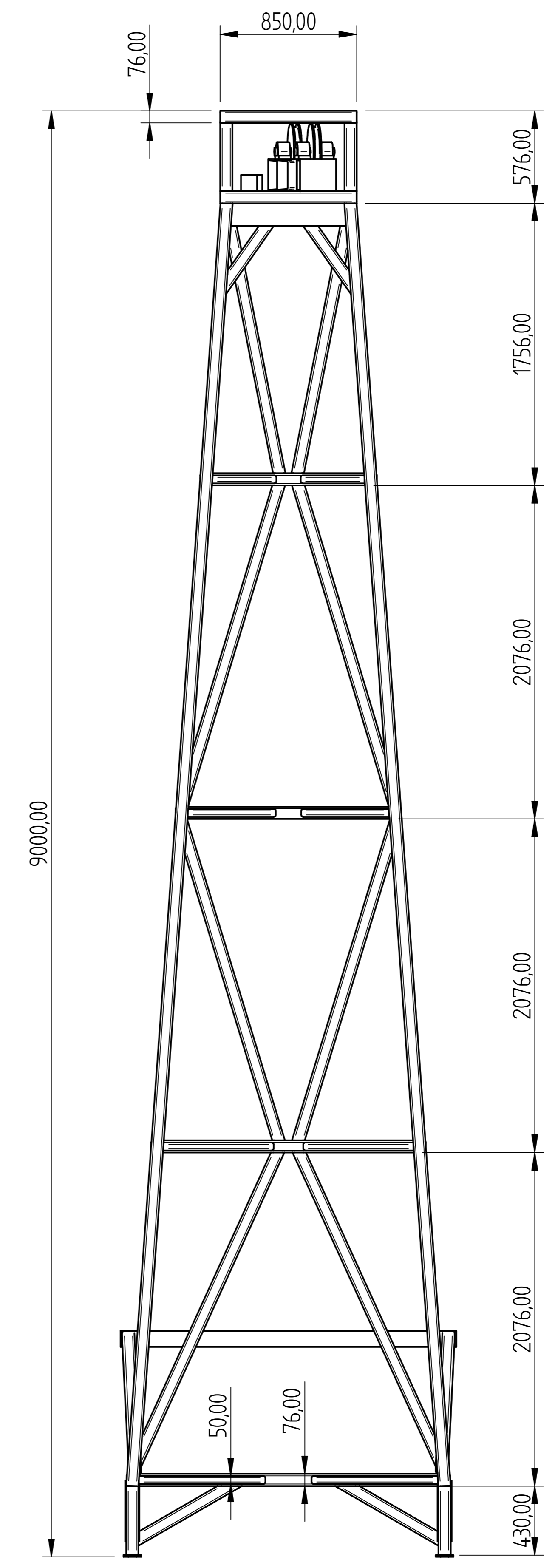

DEAD MAN ARM

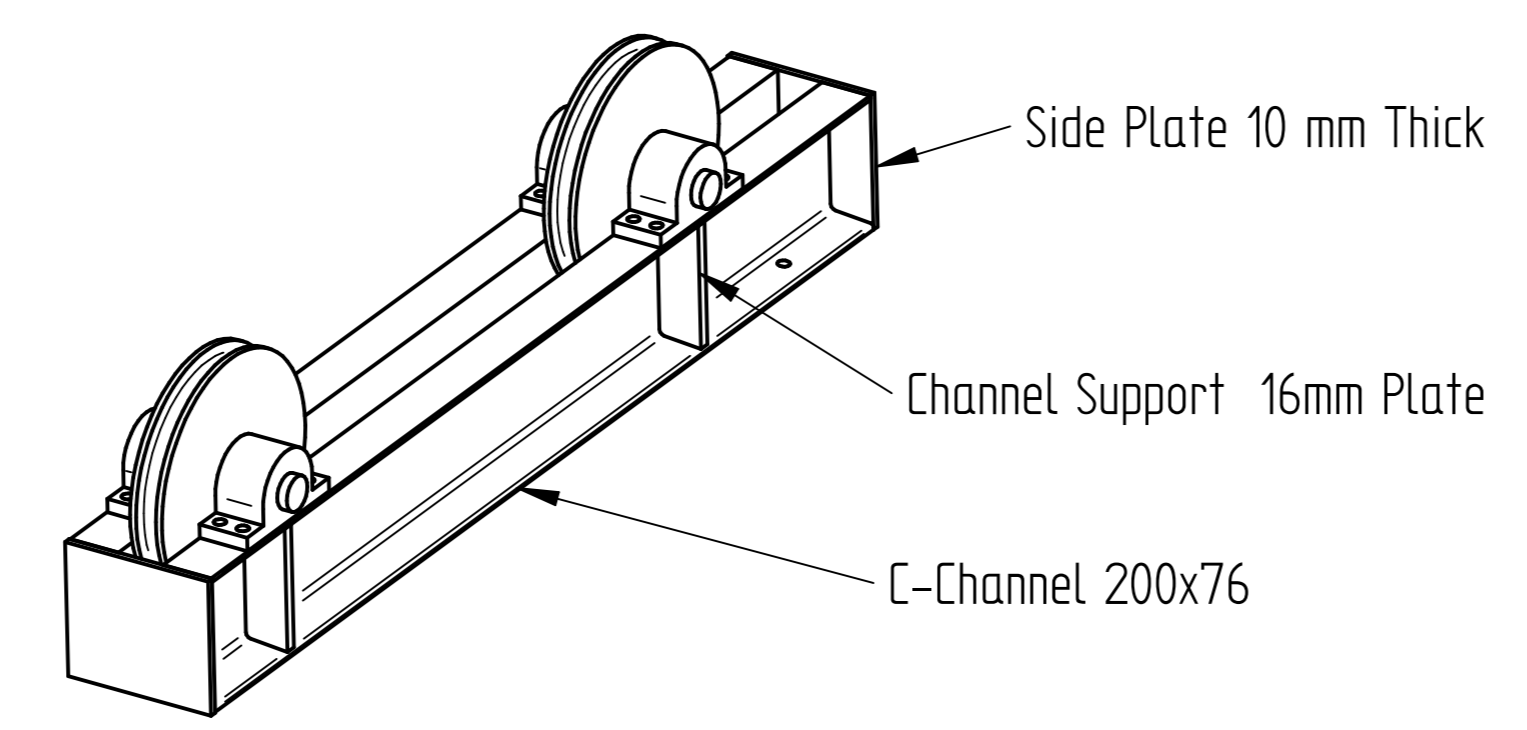

SHEAVE WHEEL BRACKET

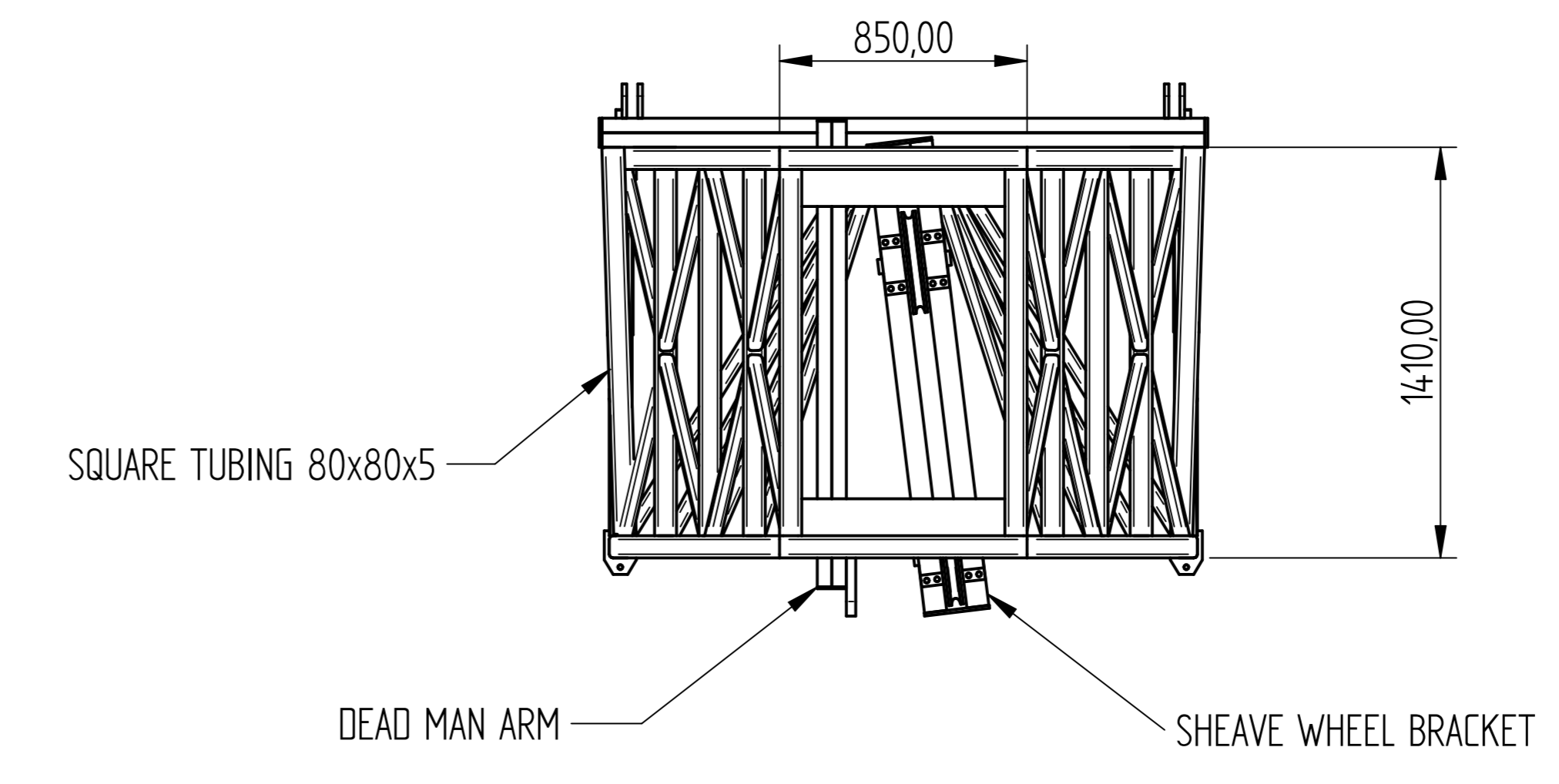

1440 DERRICK
1440-D-000

MATERIAL: SABS 1431 GRADE S355JR
ALL WELDING 10mm FILLET

NAME	DATE	TITLE
DRAWN: Dgn	02/07/13	EQUAL CHANCE TRADING 50
APPROVED:		
MATERIAL:		1440 DERRICK
TREATMENT:		
UNLESS OTHERWISE SPECIFIED DIMENSIONS ARE IN MILLIMETERS		SIZE: A0
ANGLES: ±0.1°		FILE NAME: 1440 Derrick.dwg
2 PL ±0.02	3 PL ±0.005	SCALE: WEIGHT: SHEET 2 OF 2