

REVISION HISTORY			
REV	DESCRIPTION	DATE	APPROVED

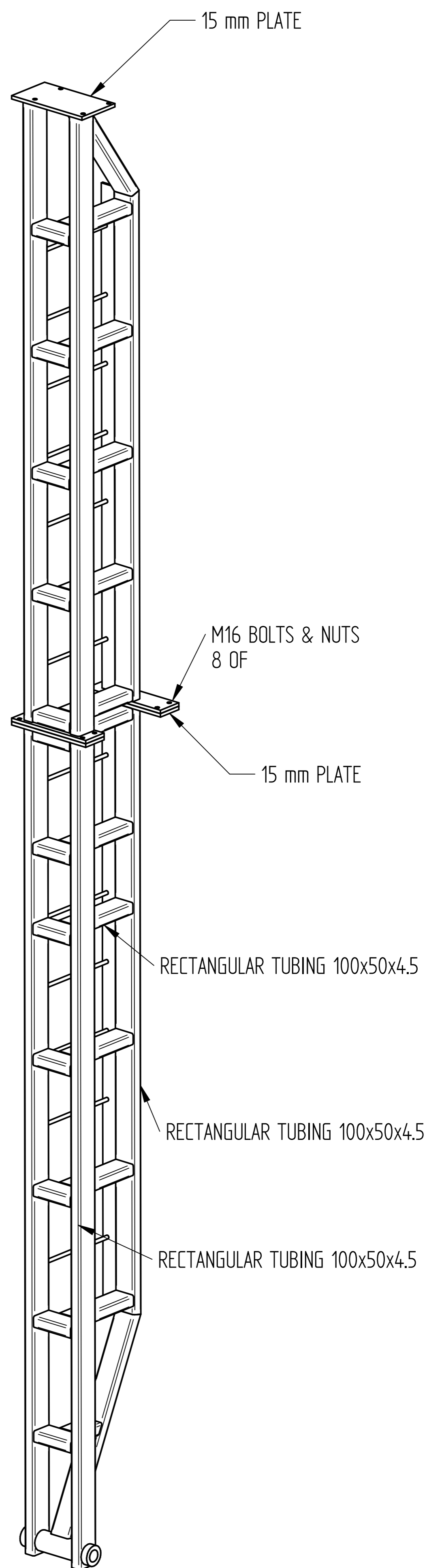
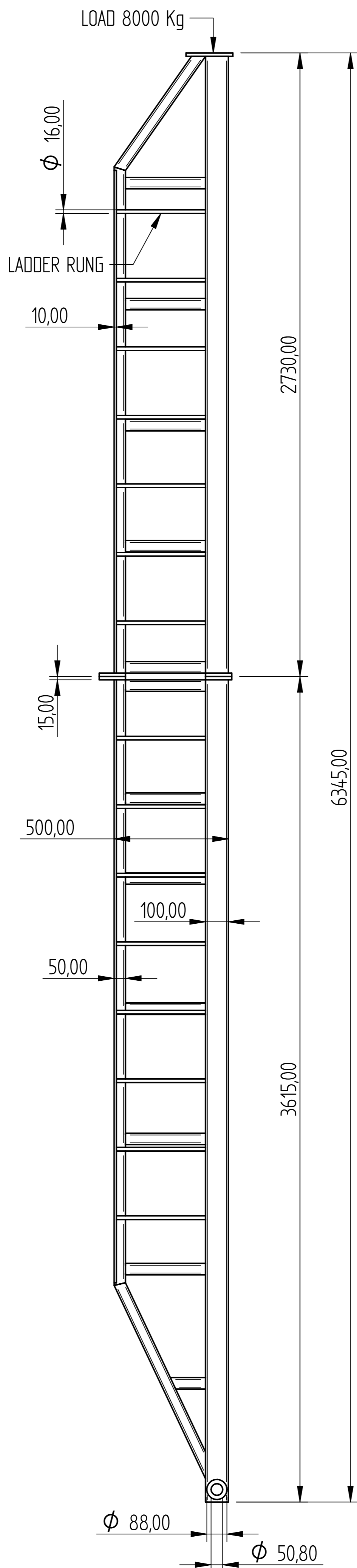
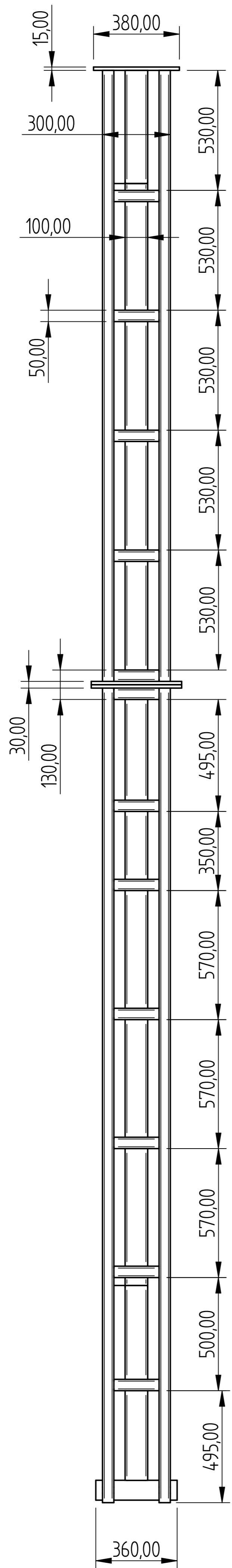

MATERIAL: SABS 1431 GRADE S355JR  
ALL WELDING 10mm FILLET

NAME	DATE	EQUAL CHANCE TRADING 50	
DRAWN: D.L.G.	07/27/11	TITLE: Derrick Frame 1400	
APPROVED:		FILE NAME: Derrick Frame 1400.dft	
MATERIAL:		SCALE: WEIGHT: SHEET 1 OF 1	
TREATMENT:		UNLESS OTHERWISE SPECIFIED DIMENSIONS ARE IN MILLIMETERS	
		ANGLES ±0.1°	
		1:50 SCALE 2 PL ±0.02 3 PL ±0.005	