

Floor grid C
1400-CF-003

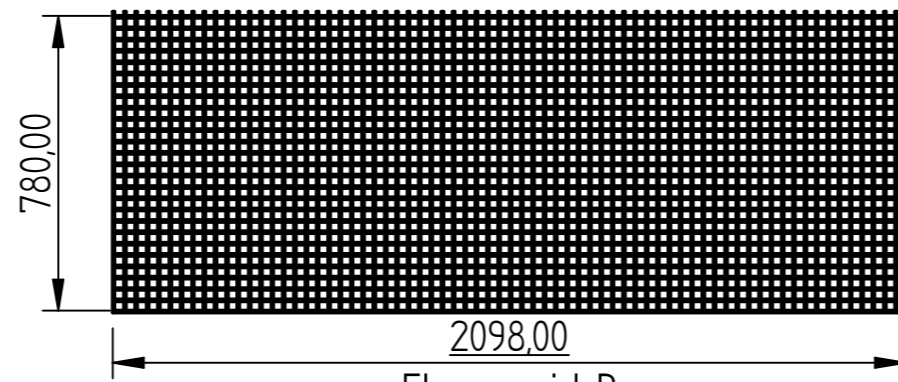

Floor grid B
1400-CF-002

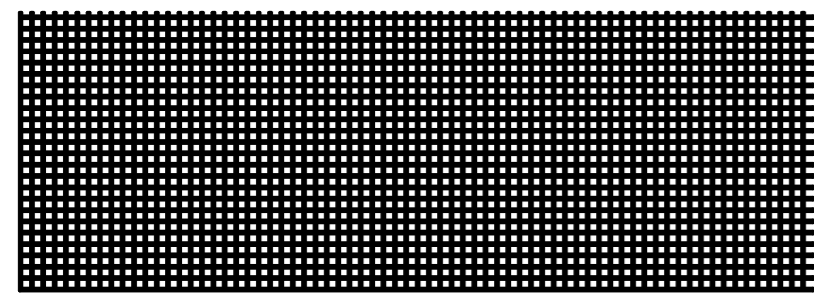

Floor grid A
1400-CF-001

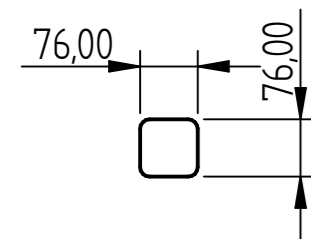

Railing covers
1400-CF-026

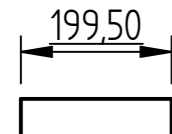

Railing top F
1400-CF-011

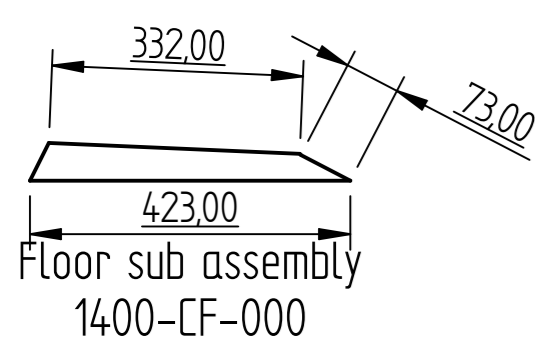

Floor sub assembly
1400-CF-000

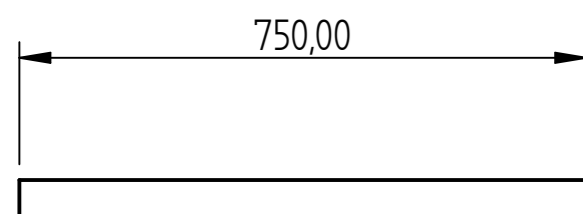

Railing top C
1400-CF-008

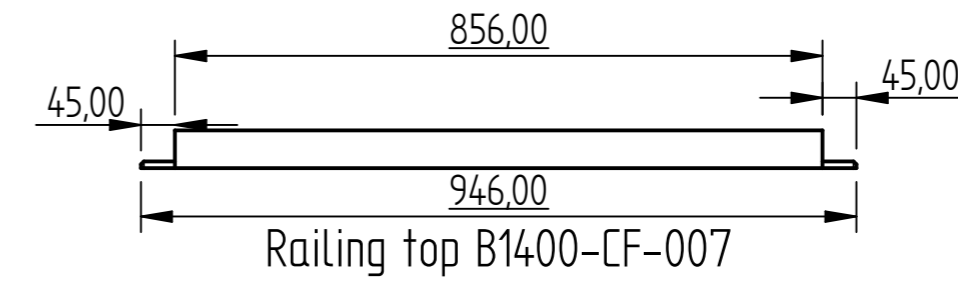
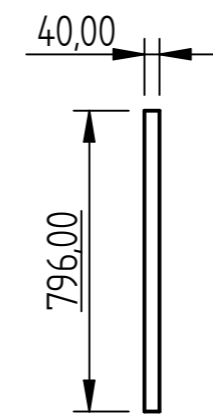
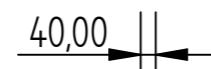

Railing top B1400-CF-007

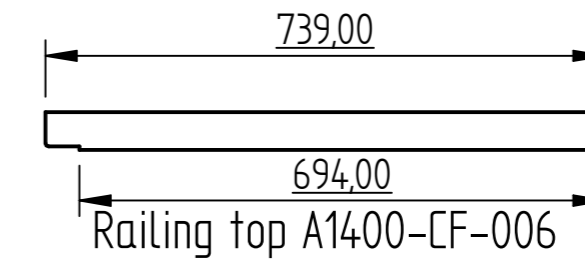
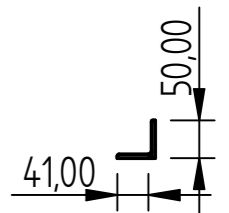

Railing top A1400-CF-006

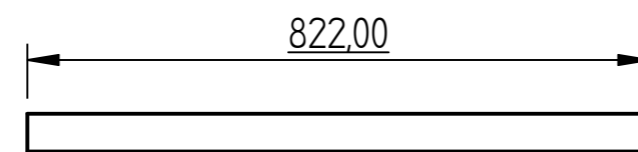
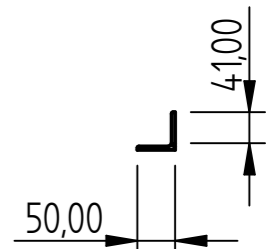

Railing top D1400-CF-009

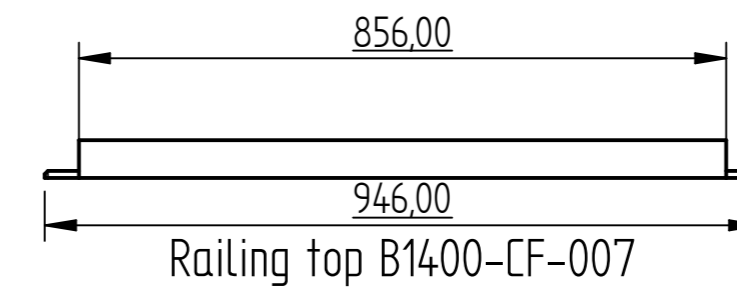
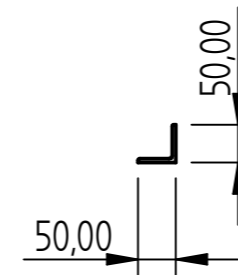

Railing top B1400-CF-007

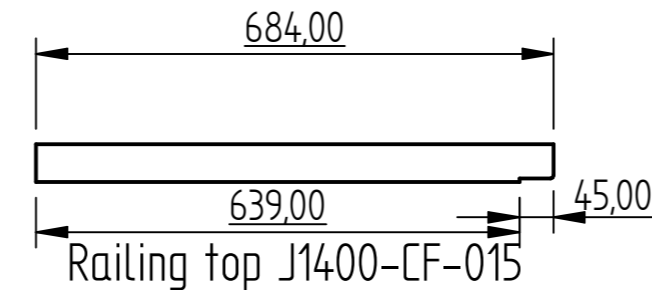
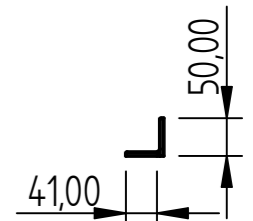

Railing top J1400-CF-015

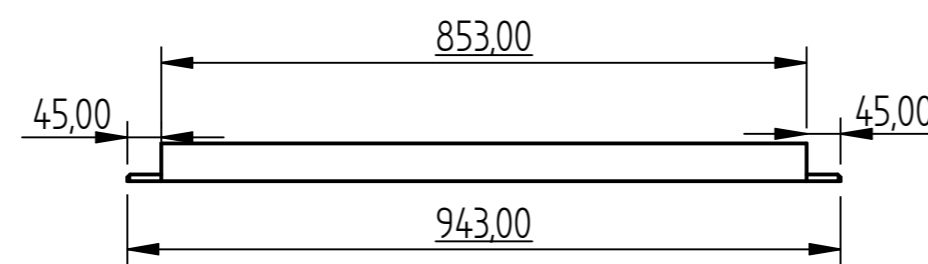
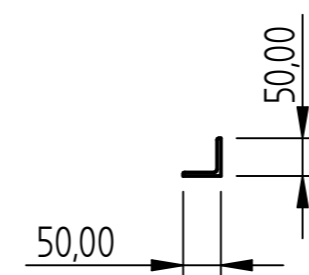

Railing top I1400-CF-014

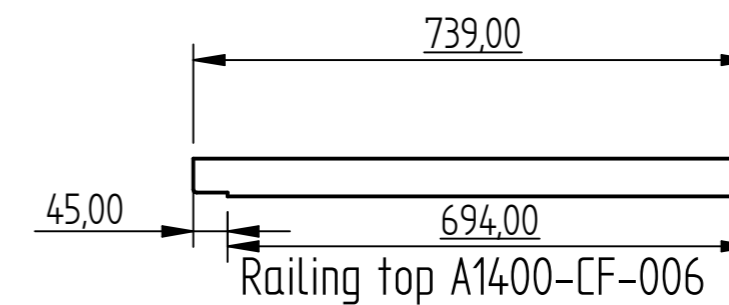
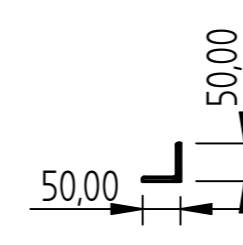

Railing top A1400-CF-006

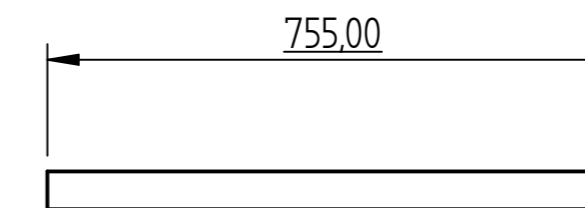
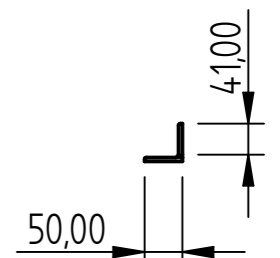

Railing top H1400-CF-013

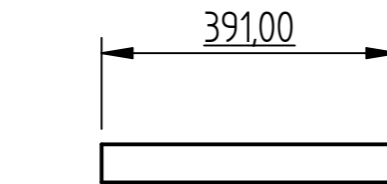
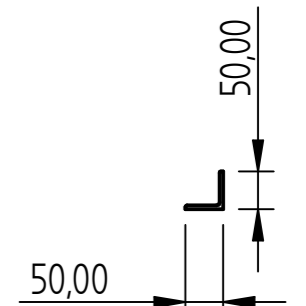

Railing top G1400-CF-012

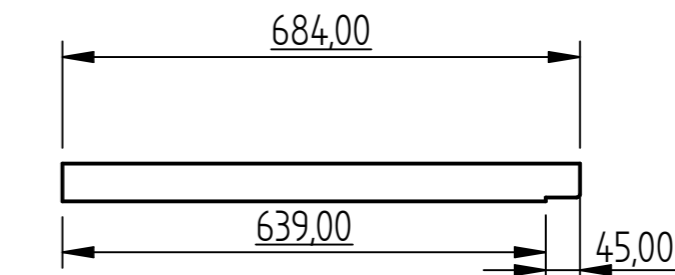
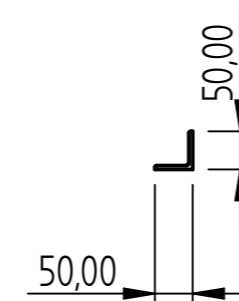

Railing top J1400-CF-015

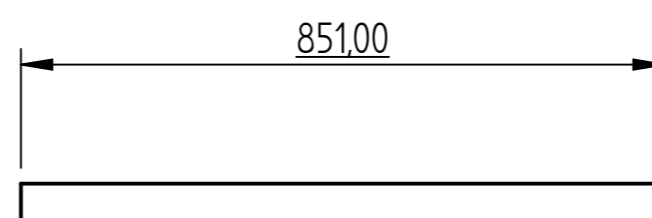
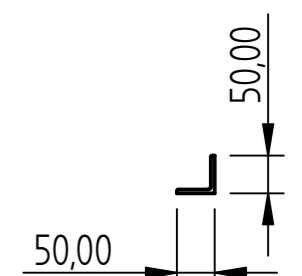

Railing upright B1400-CF-005

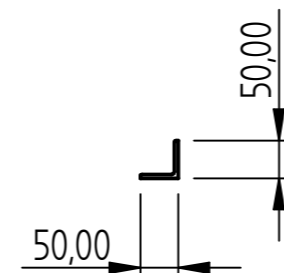

NAME	DATE	EQUAL CHANCE TRADING 50		
DRAWN	A J Davey	01/28/13	TITLE	
APPROVED			Floor sub assembly	
MATERIAL			SIZE	DWG NO
TREATMENT			A2	1400-CF-000
UNLESS OTHERWISE SPECIFIED DIMENSIONS ARE IN MILLIMETERS			SCALE:	WEIGHT:
1st ANGLE ANGLES ±0.1°			FILE NAME: Floor sub assembly.dft	REV
2 PL ±0.02 3 PL ±0.005				SHEET 2 OF 3

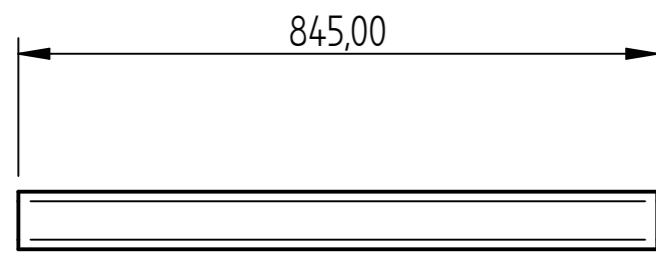

Railing upright A1400-CF-004

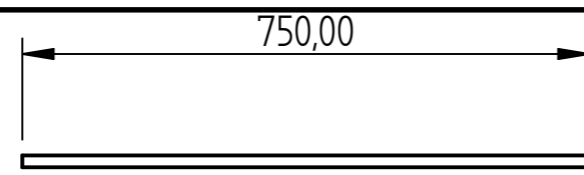
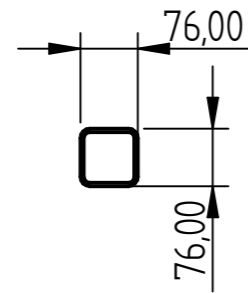

ϕ 16,00

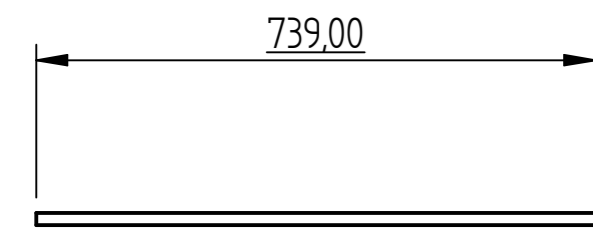
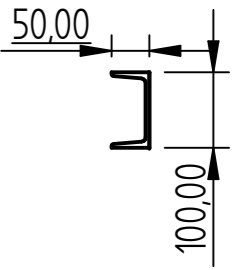
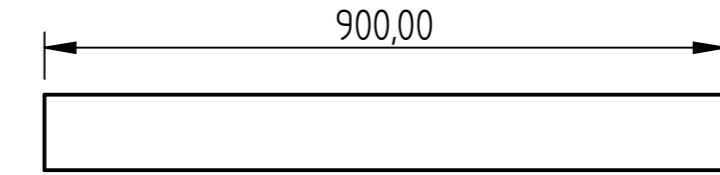

Railing center A1400-CF-016

ϕ 16,00

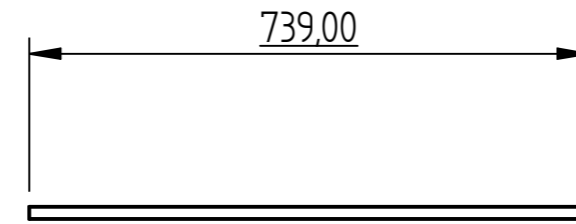

ϕ 16,00

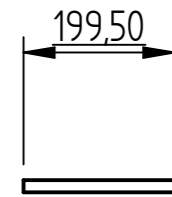
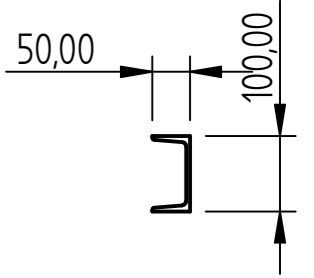
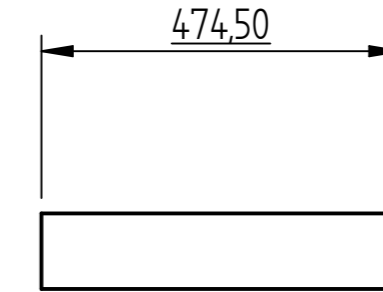

ϕ 16,00

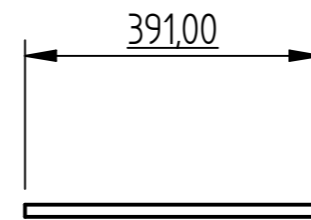

ϕ 16,00

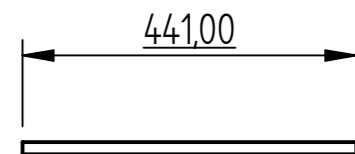
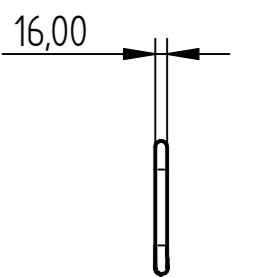
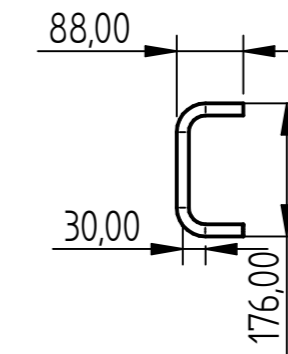

ϕ 16,00

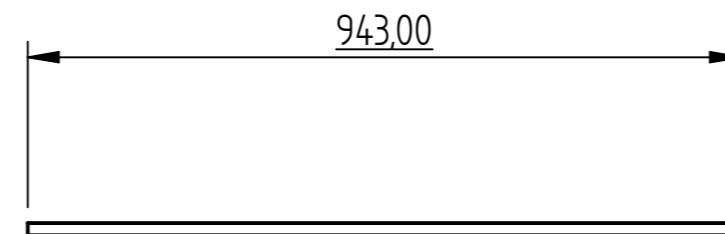

ϕ 16,00

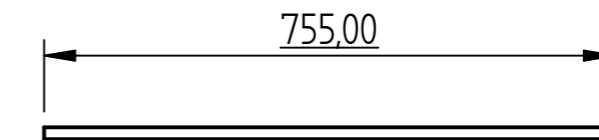

ϕ 16,00

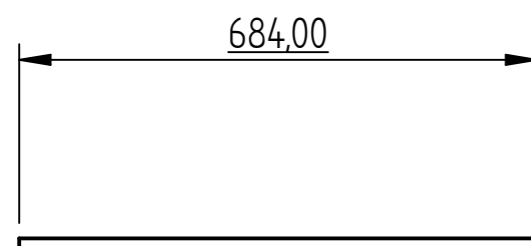

ϕ 16,00

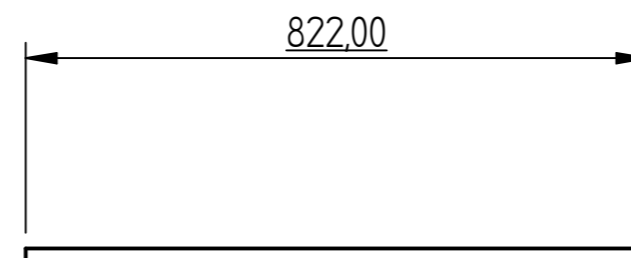

ϕ 16,00

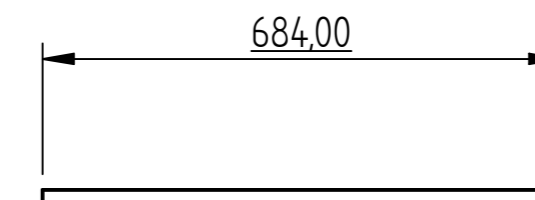

ϕ 16,00

DRAWN	NAME	DATE	EQUAL CHANCE TRADING 50		
APPROVED	A J Davey	01/28/13	TITLE		
MATERIAL			Floor sub assembly		
TREATMENT			SIZE	DWG NO	REV
UNLESS OTHERWISE SPECIFIED DIMENSIONS ARE IN MILLIMETERS			A2	1400-CF-000	
1 st ANGLE			FILE NAME: Floor sub assembly.dft		
2 PL ±0.02 3 PL ±0.005			SCALE:	WEIGHT:	SHEET 3 OF 3