

REVISION HISTORY			
REV	DESCRIPTION	DATE	APPROVED

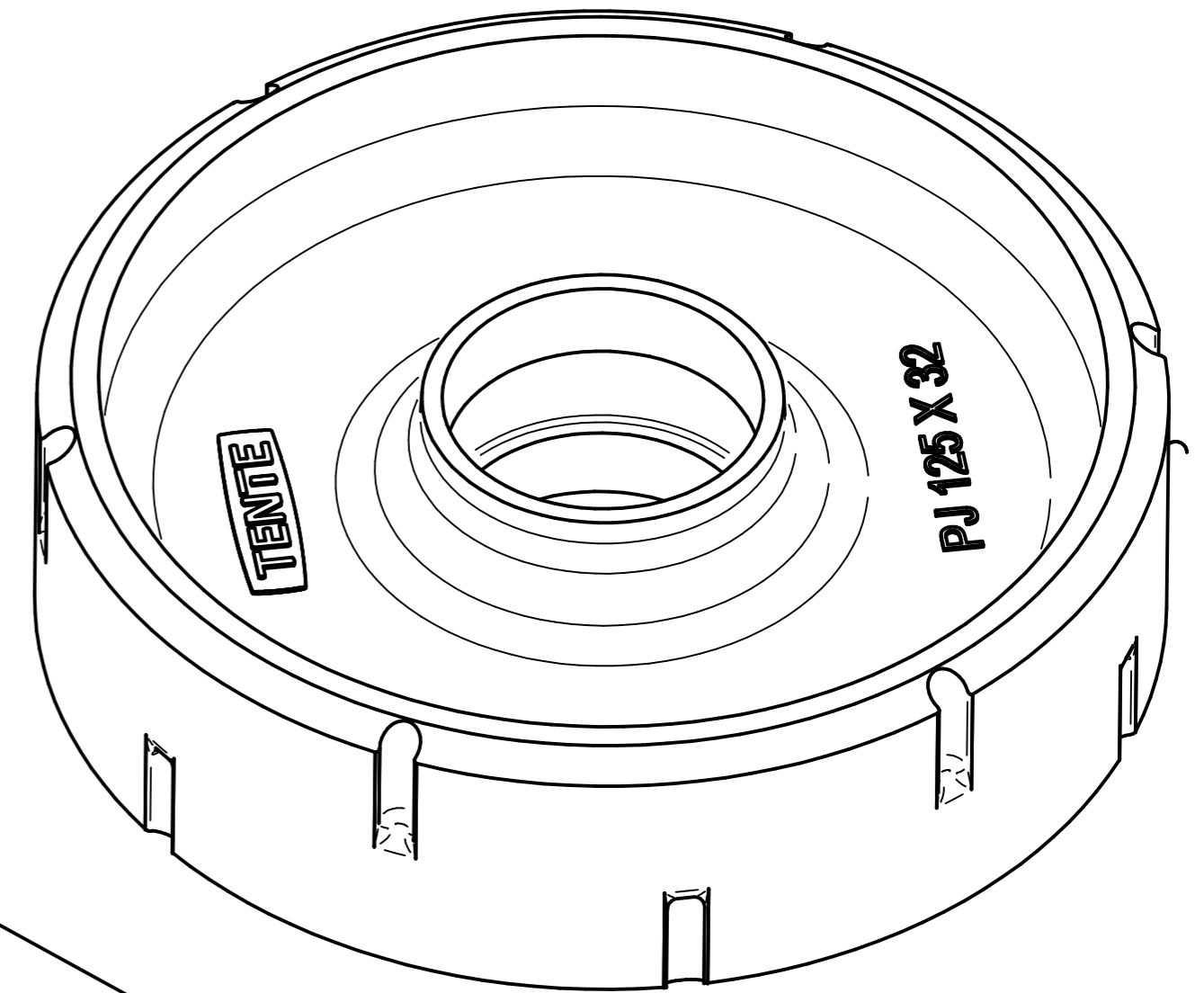

DRAWN	NAME	DATE	PREMAC		
APPROVED	Dan	05/22/18			
MATERIAL					
TREATMENT					
UNLESS OTHERWISE SPECIFIED DIMENSIONS ARE IN MILLIMETERS ANGLES ±0.1°			SIZE A4	DWG NO	REV
1st ANGLE 2 PL ±0.02 3 PL ±0.005			FILE NAME: PJP125X32 WC-ND Wheel Centre Mould.dff		
			SCALE:	WEIGHT:	SHEET 1 OF 7

REVISION HISTORY			
REV	DESCRIPTION	DATE	APPROVED

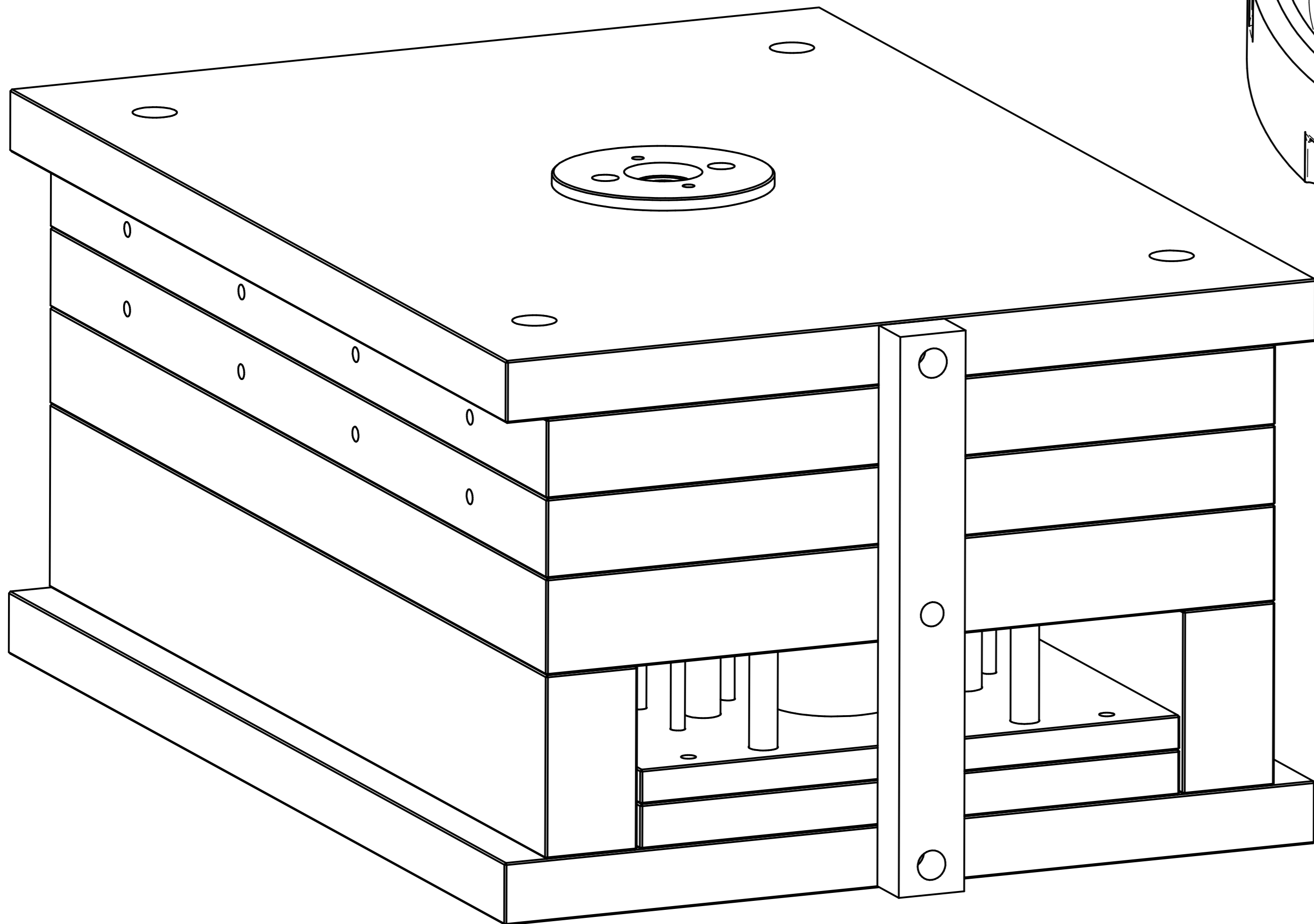
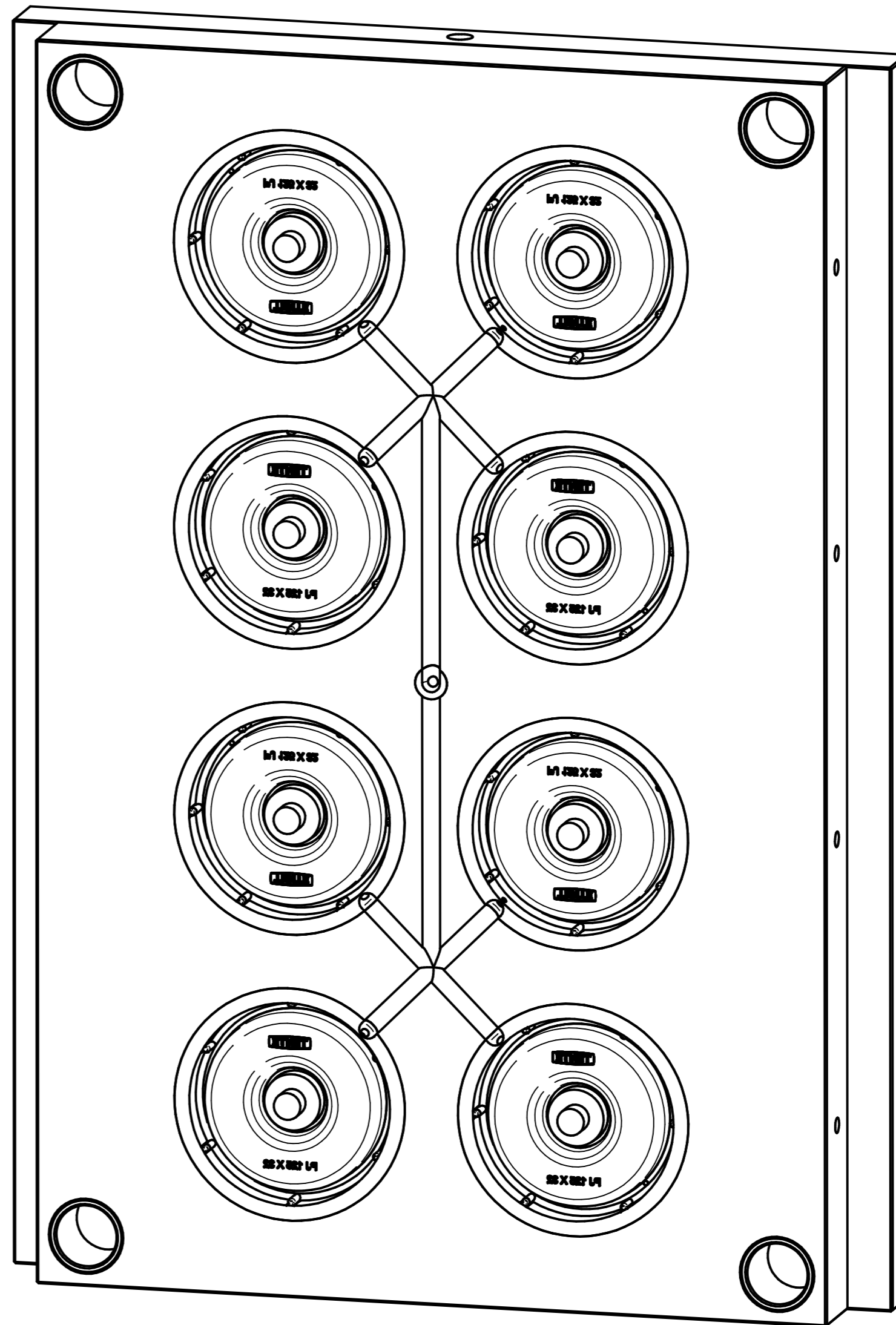
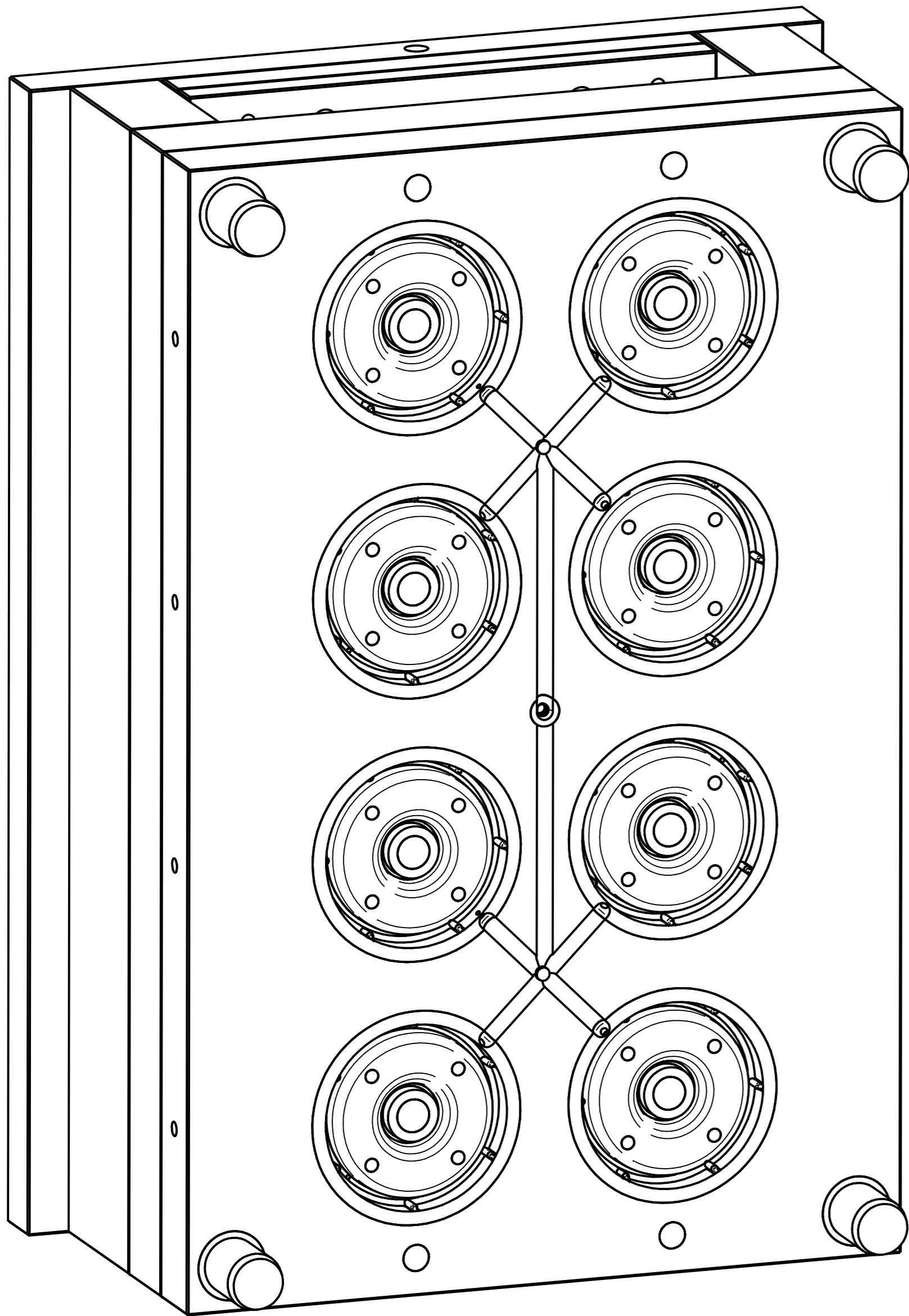

DRAWN	NAME	DATE	PREMAC		
APPROVED	Dan	05/22/18			
MATERIAL					
TREATMENT					
UNLESS OTHERWISE SPECIFIED DIMENSIONS ARE IN MILLIMETERS			SIZE	DWG NO	REV
1 ST ANGLE ANGLES ±0.1°			A4		
2 PL ±0.02 3 PL ±0.005			FILE NAME: PJP125X32 WC-ND Wheel Centre Mould.dff		
SCALE:		WEIGHT:		SHEET 2 OF 7	

REVISION HISTORY			
REV	DESCRIPTION	DATE	APPROVED

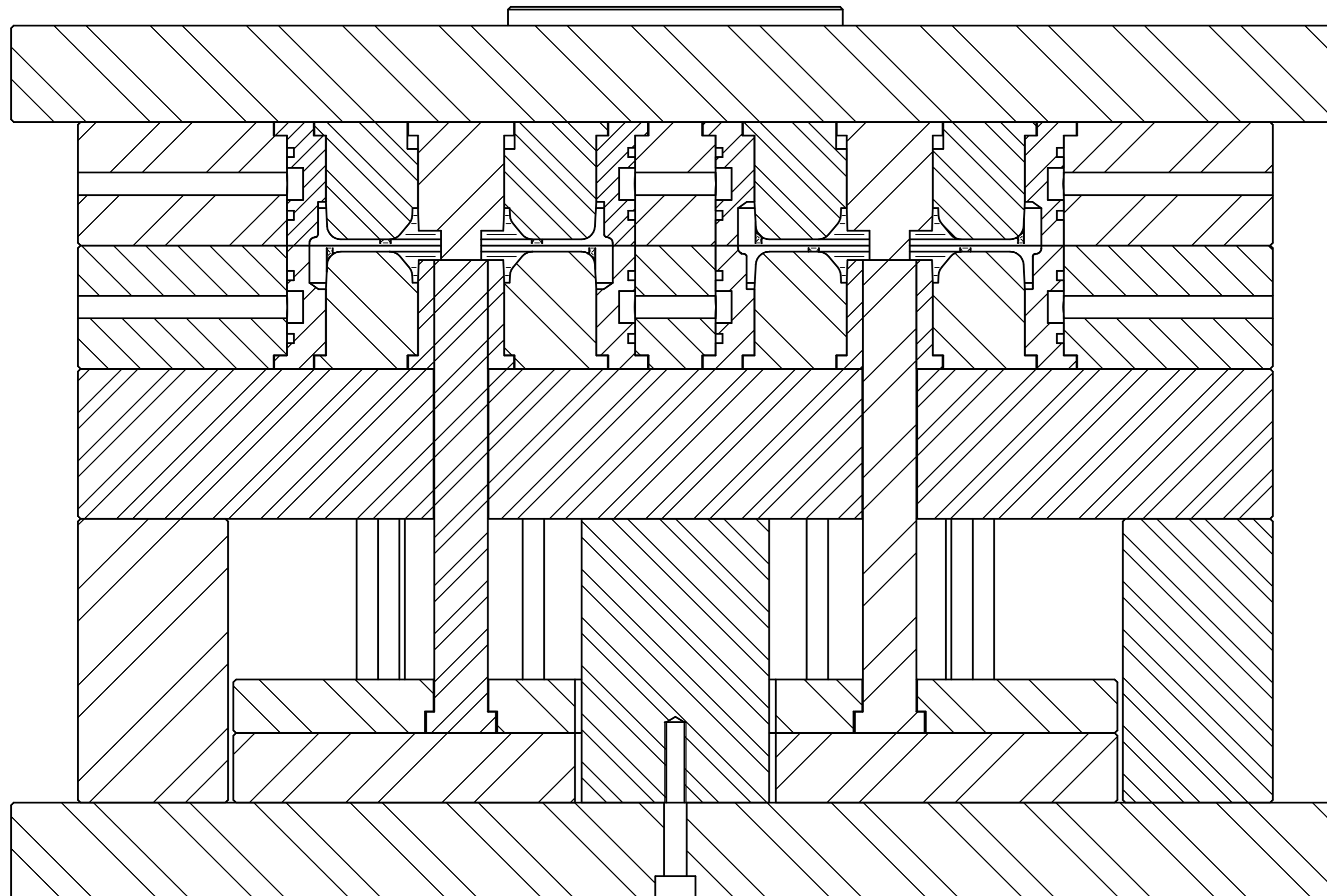

	NAME	DATE	PREMAC	
DRAWN	Dan	05/22/18		
APPROVED				
MATERIAL				
TREATMENT			TITLE	
UNLESS OTHERWISE SPECIFIED DIMENSIONS ARE IN MILLIMETERS			SIZE A4	DWG NO
1 ST ANGLE ANGLES ±0.1°			FILE NAME: PJP125X32 WC-ND Wheel Centre Mould.dff	REV
2 PL ±0.02 3 PL ±0.005			SCALE:	WEIGHT:
			SHEET 3 OF 7	

REVISION HISTORY			
REV	DESCRIPTION	DATE	APPROVED

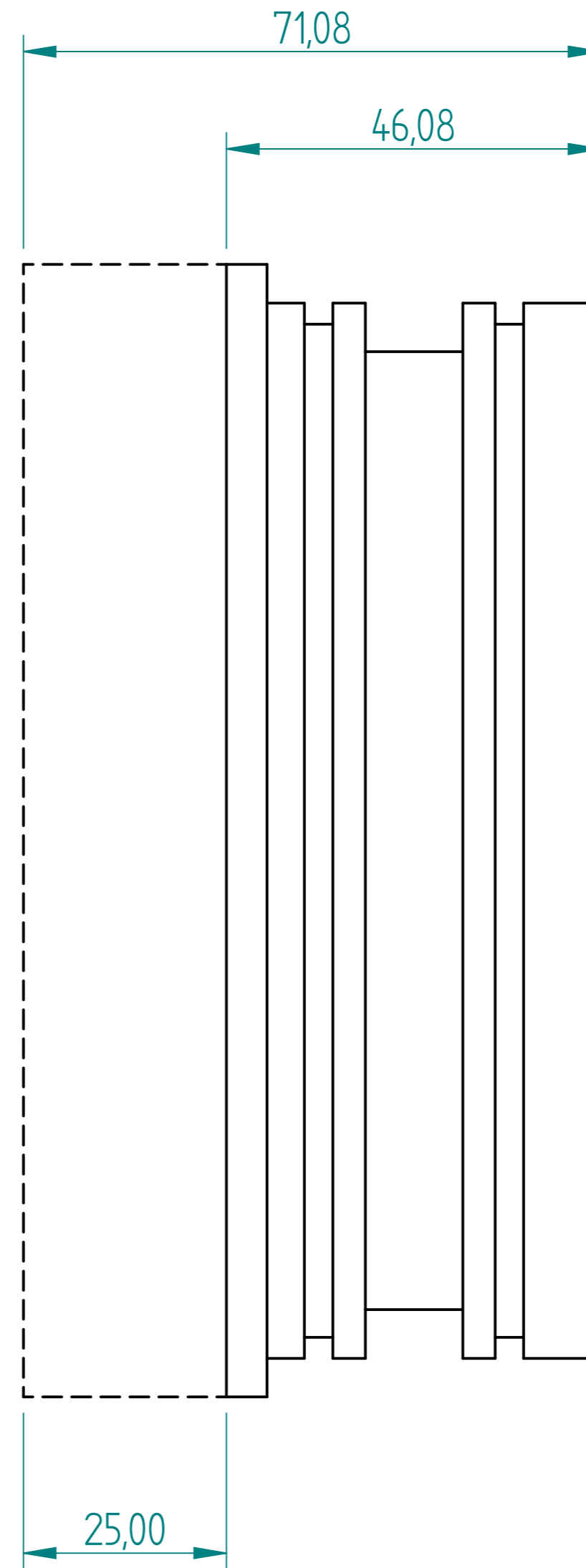
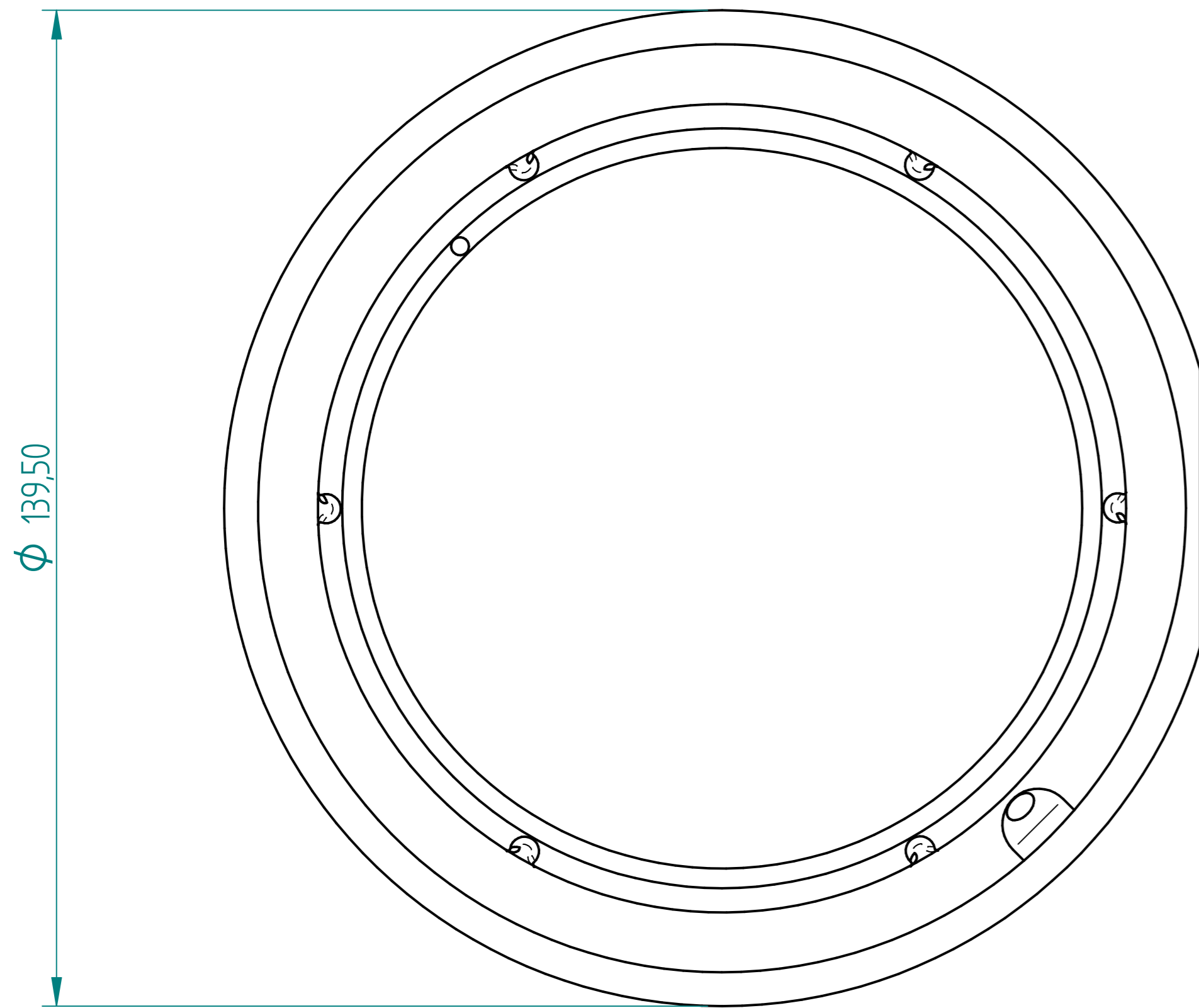

FH and MH WC OUTER INSERT
 16 OFF
 R950 each

	NAME	DATE	PREMAC	
DRAWN	Dan	05/22/18		
APPROVED				
MATERIAL				
TREATMENT			TITLE	
UNLESS OTHERWISE SPECIFIED DIMENSIONS ARE IN MILLIMETERS			SIZE A4	DWG NO
1 ST ANGLE ANGLES $\pm 0.1^\circ$			FILE NAME: PJP125X32 WC-ND Wheel Centre Mould.dff	
2 PL ± 0.02 3 PL ± 0.005			SCALE:	WEIGHT:
			SHEET 4 OF 7	

REVISION HISTORY			
REV	DESCRIPTION	DATE	APPROVED

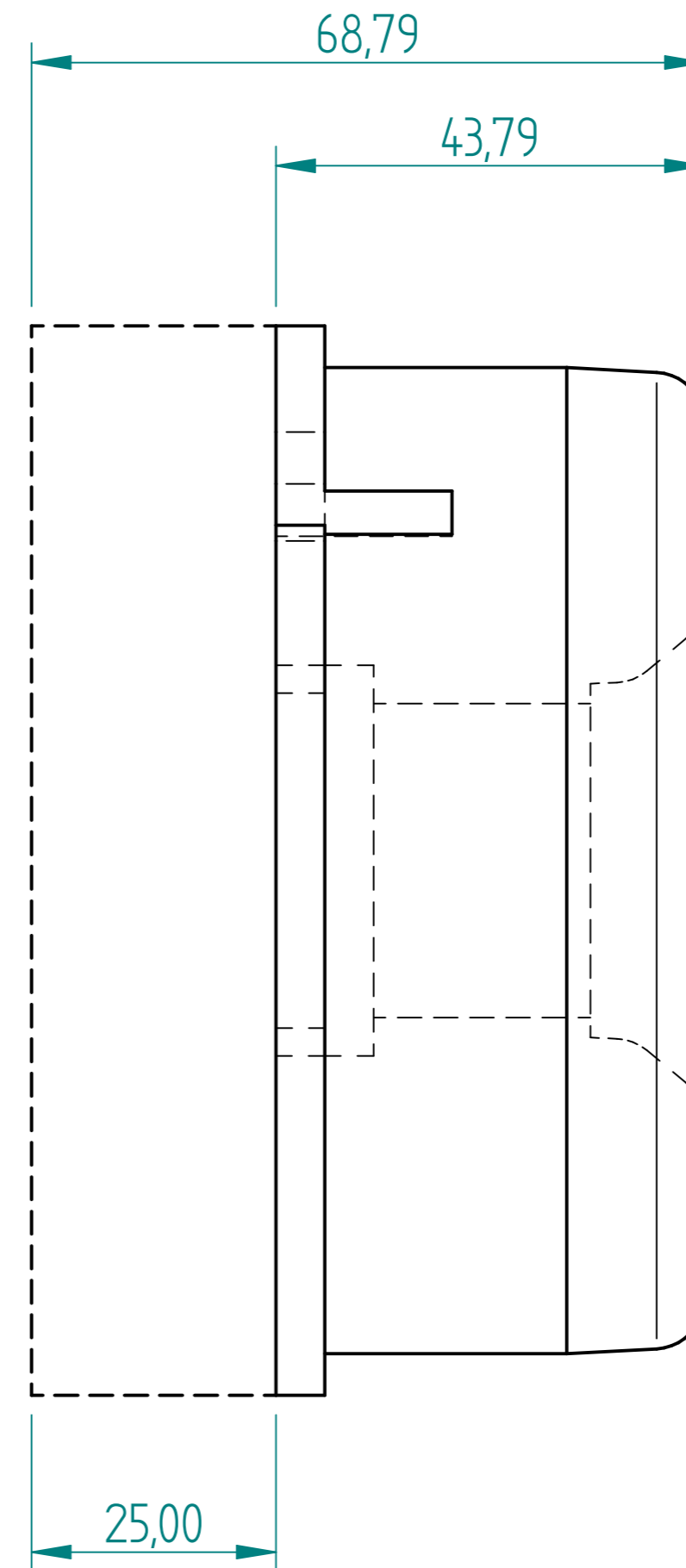
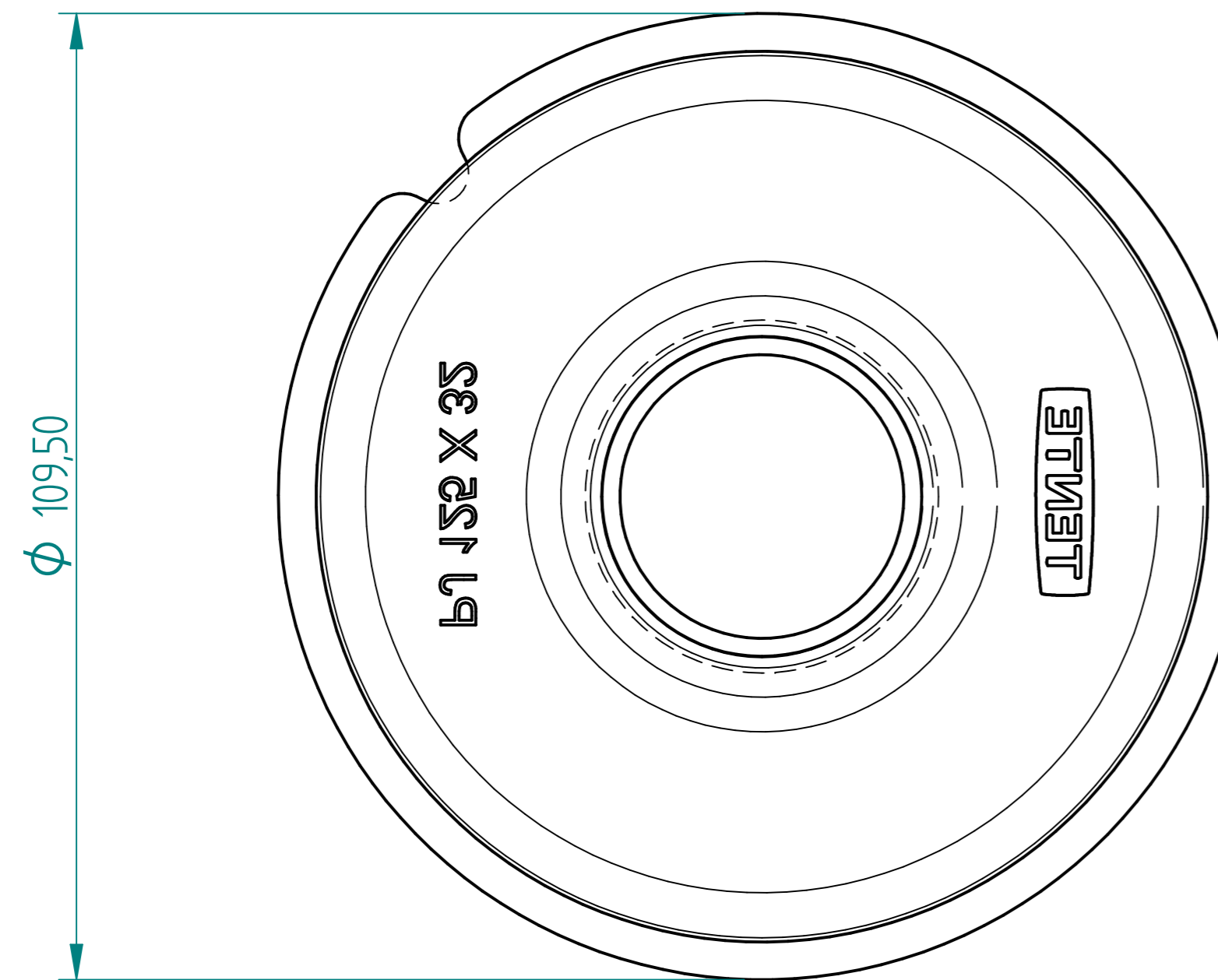

FH and MH WC CENTRE INSERT
 16 OFF
 R750 each

	NAME	DATE	PREMAC	
DRAWN	Dan	05/22/18		
APPROVED			TITLE	
MATERIAL				
TREATMENT				
UNLESS OTHERWISE SPECIFIED DIMENSIONS ARE IN MILLIMETERS			SIZE A4	DWG NO
1 ST ANGLE 			FILE NAME: PJP125X32 WC-ND Wheel Centre Mould.dff	REV
2 PL ±0.02 3 PL ±0.005			SCALE:	WEIGHT:
			SHEET 5 OF 7	

REVISION HISTORY			
REV	DESCRIPTION	DATE	APPROVED

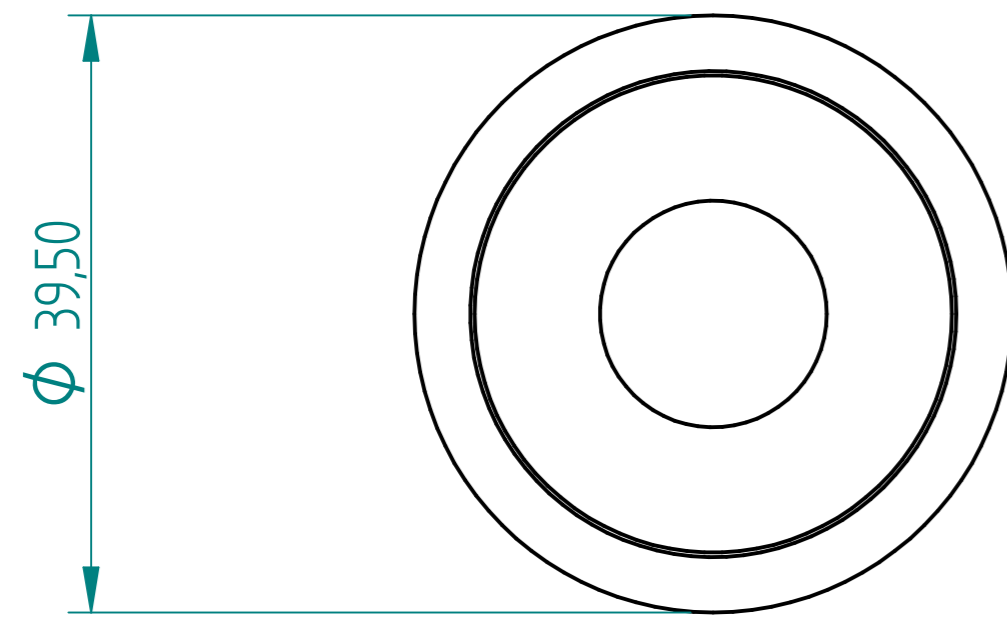

FH WC INNER INSERT
8 OFF
R300 each

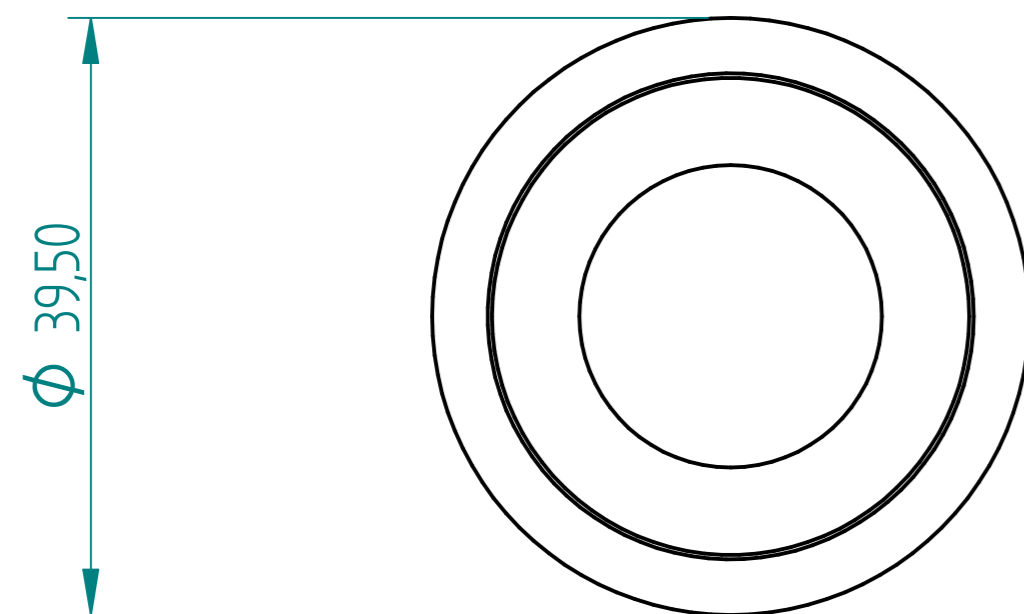
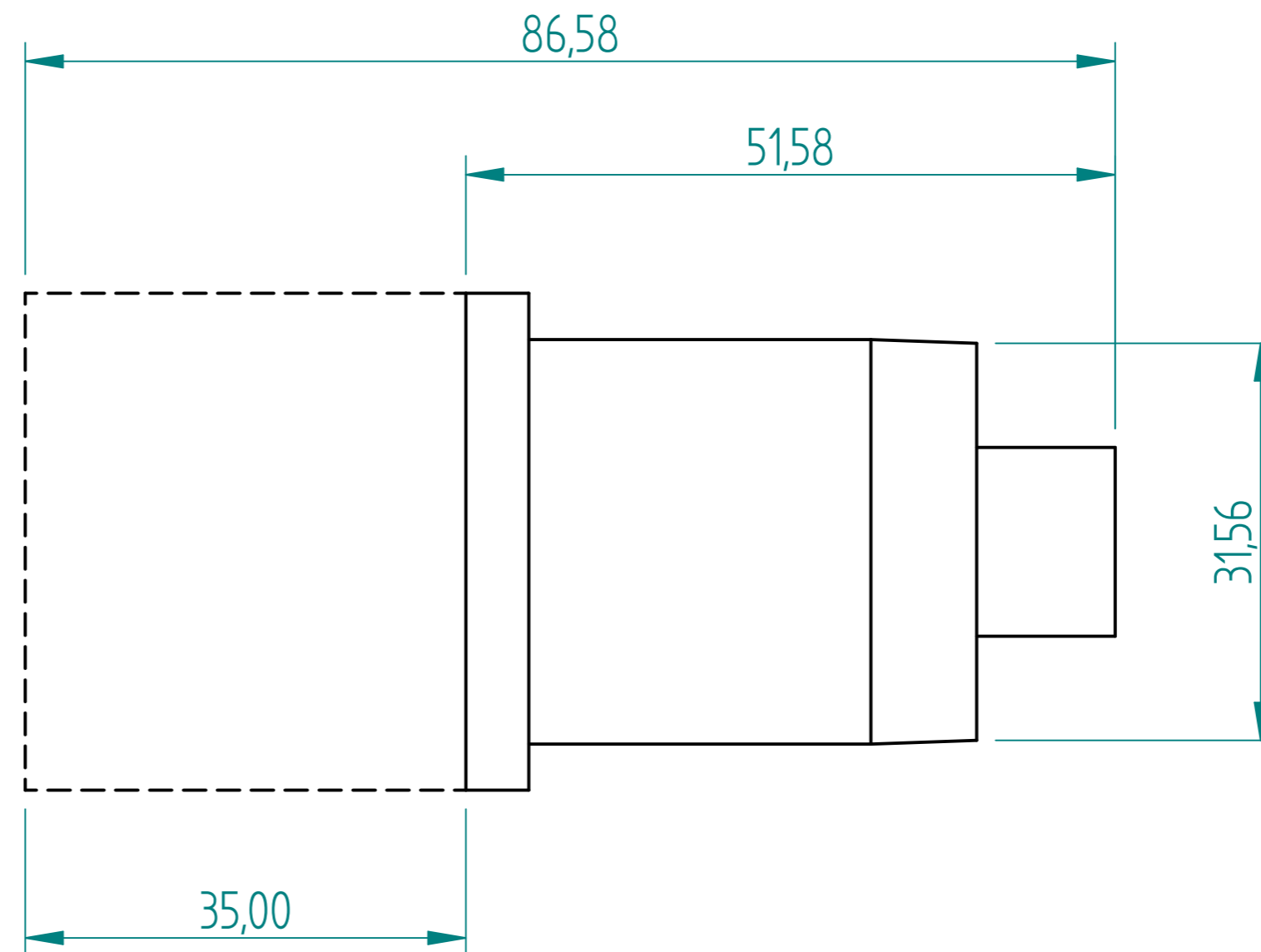

MH WC INNER INSERT
8 OFF
R350 each

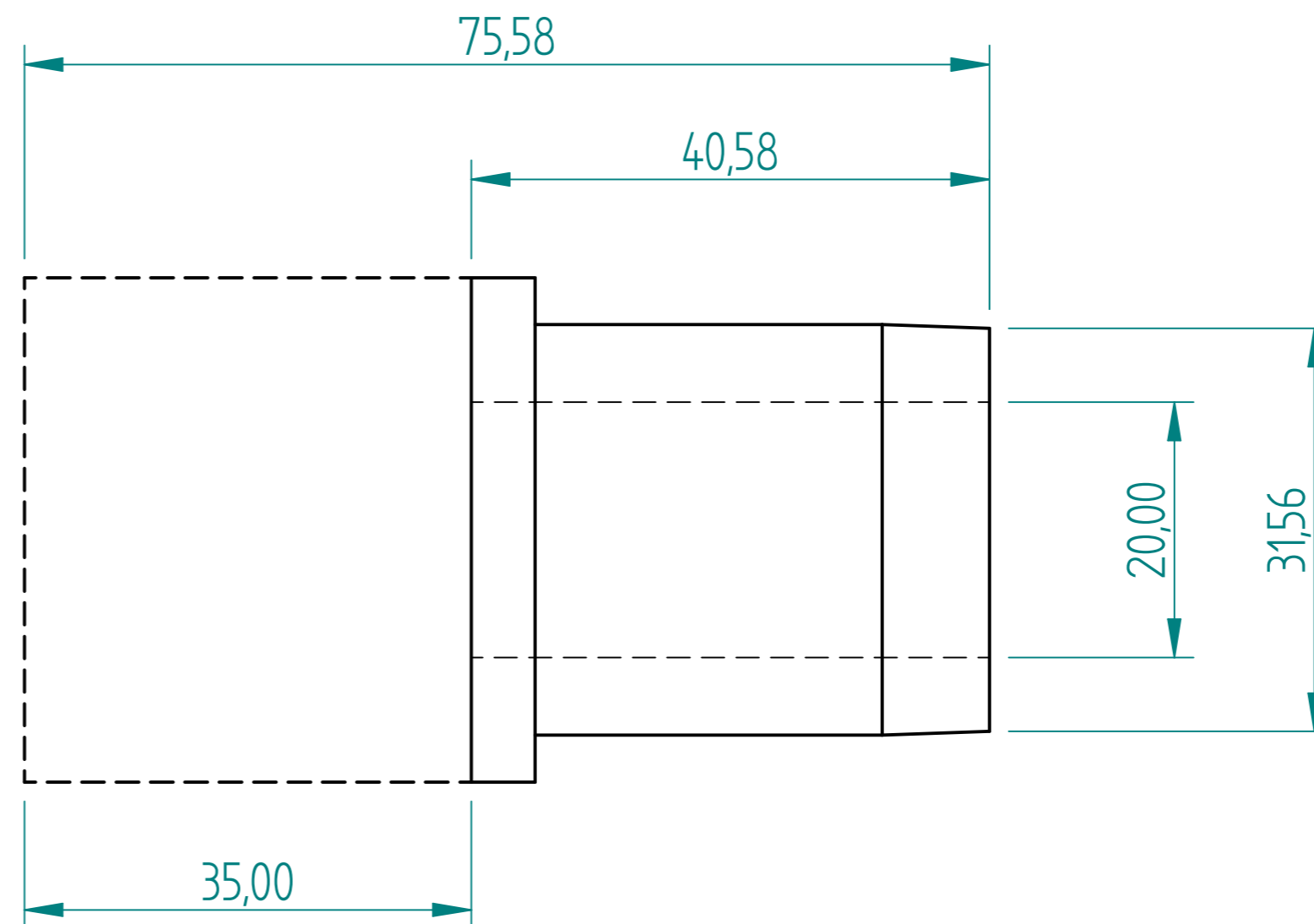

	NAME	DATE	PREMAC	
DRAWN	Dan	05/22/18		
APPROVED				
MATERIAL				
TREATMENT			TITLE	
UNLESS OTHERWISE SPECIFIED DIMENSIONS ARE IN MILLIMETERS			SIZE A4	DWG NO
1 ST ANGLE ANGLES ±0.1°			FILE NAME: PJP125X32 WC-ND Wheel Centre Mould.dff	
2 PL ±0.02 3 PL ±0.005			SCALE:	WEIGHT:
			SHEET 6 OF 7	

REVISION HISTORY			
REV	DESCRIPTION	DATE	APPROVED

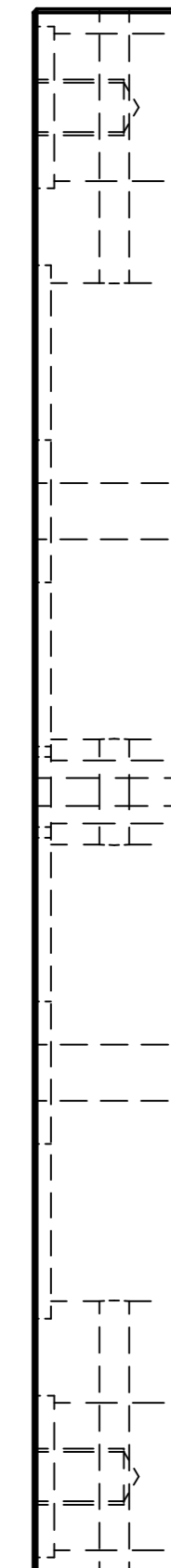
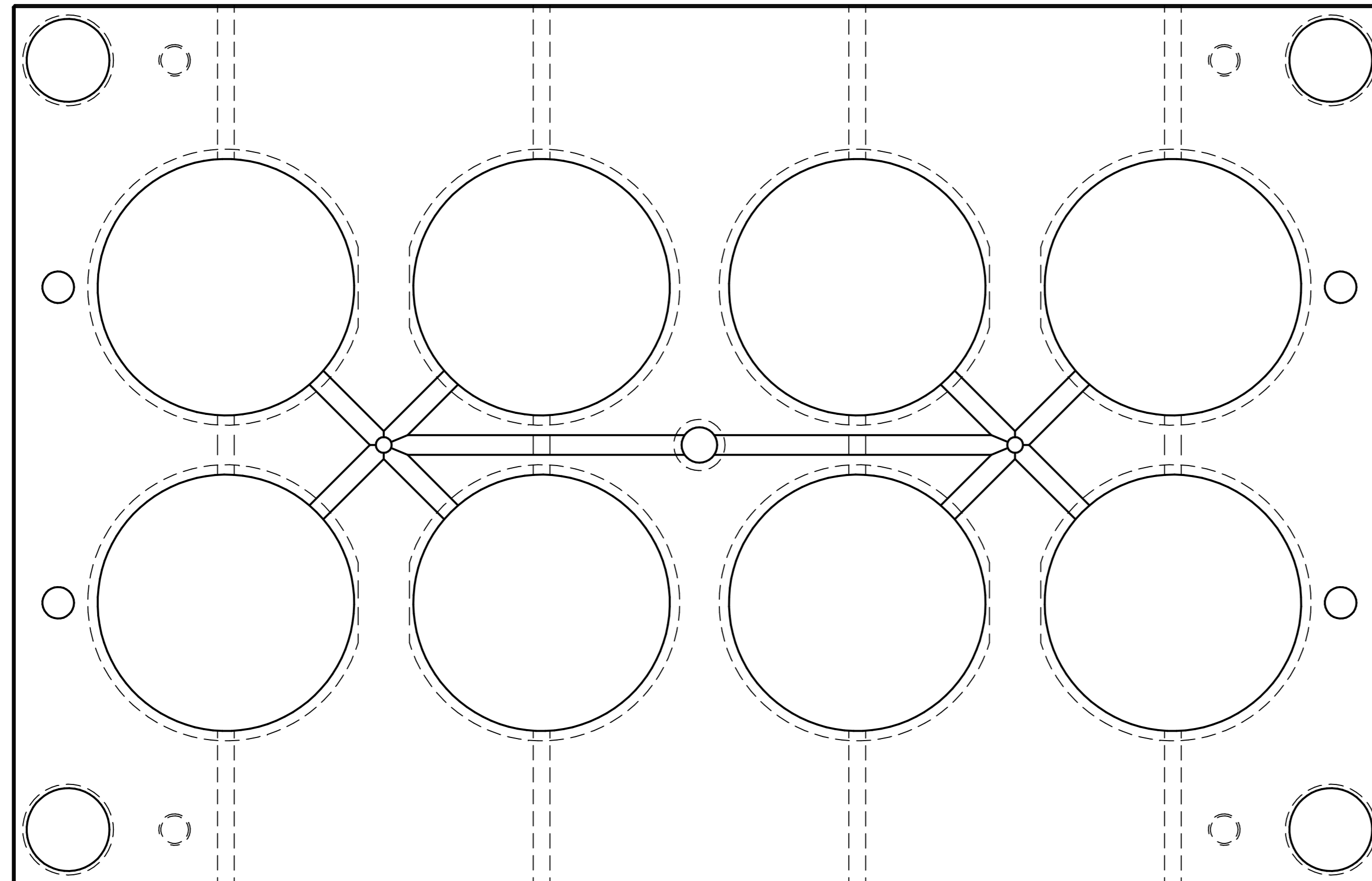

MH and FH DIE PLATES
 BOTH SIDES and WATER
 R7 000 each

	NAME	DATE	PREMAC	
DRAWN	Dan	05/22/18		
APPROVED			TITLE	
MATERIAL				
TREATMENT				
UNLESS OTHERWISE SPECIFIED <small>1st ANGLE</small> DIMENSIONS ARE IN MILLIMETERS ANGLES ±0.1°			SIZE A4	DWG NO
2 PL ±0.02 3 PL ±0.005			FILE NAME: PJP125X32 WC-ND Wheel Centre Mould.dff	REV
SCALE:		WEIGHT:	SHEET 7 OF 7	