

REVISION HISTORY			
REV	DESCRIPTION	DATE	APPROVED

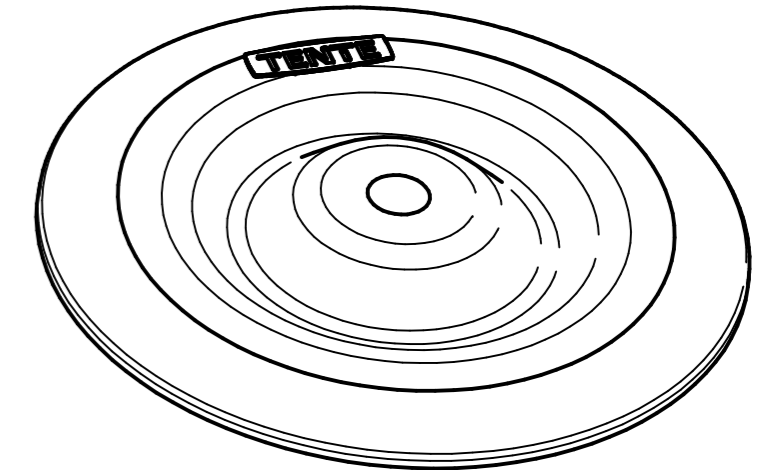

	NAME	DATE	PREMAC		
DRAWN	Dan	05/22/18			
APPROVED			TITLE		
MATERIAL					
TREATMENT			SIZE	DWG NO	REV
UNLESS OTHERWISE SPECIFIED DIMENSIONS ARE IN MILLIMETERS			A4		
1st ANGLE ANGLES ±0.1°			FILE NAME: PJP125X32 WC-ND Thread Guard Mould.dff		
2 PL ±0.02 3 PL ±0.005			SCALE:	WEIGHT:	SHEET 1 OF 7

REVISION HISTORY			
REV	DESCRIPTION	DATE	APPROVED

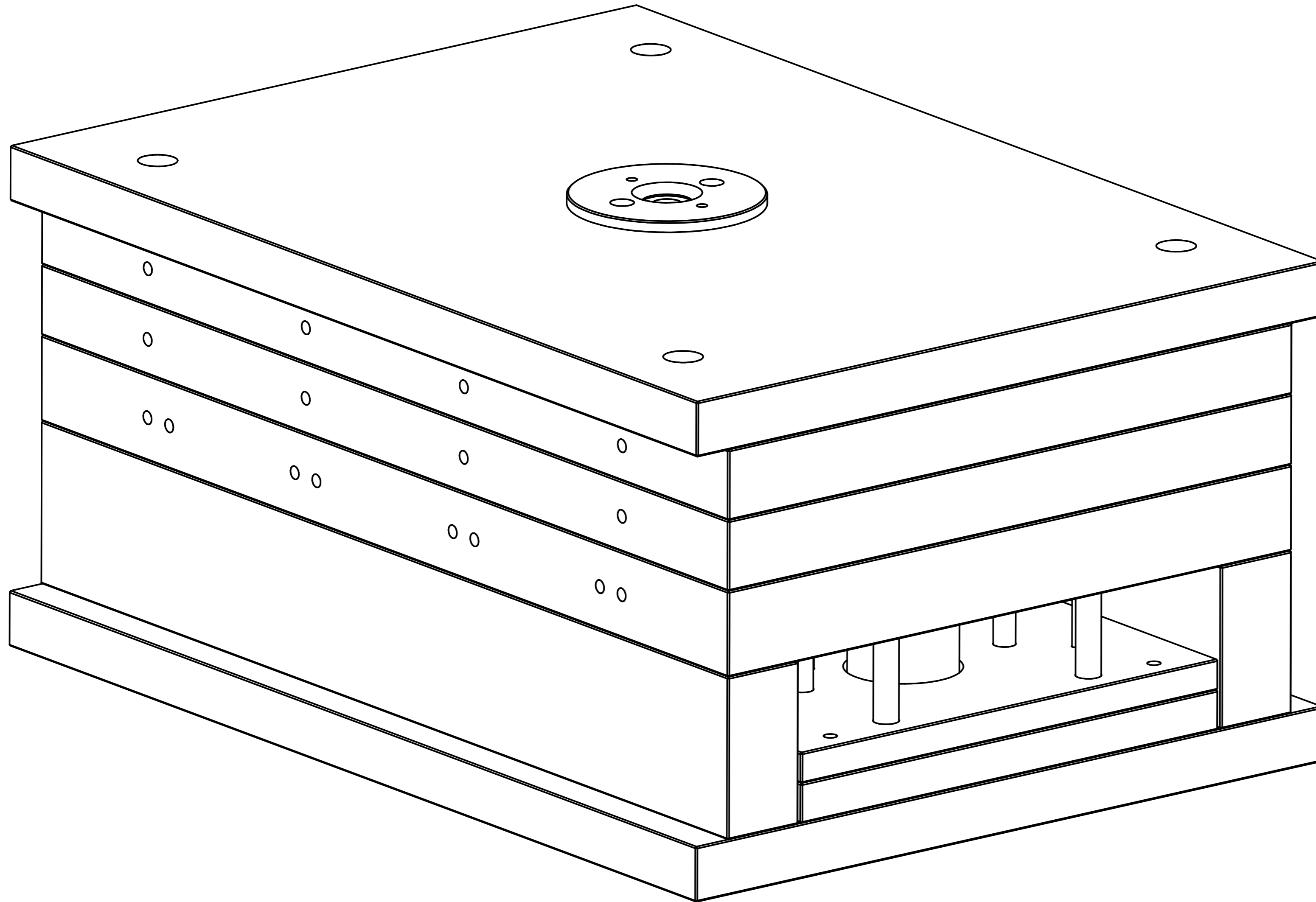
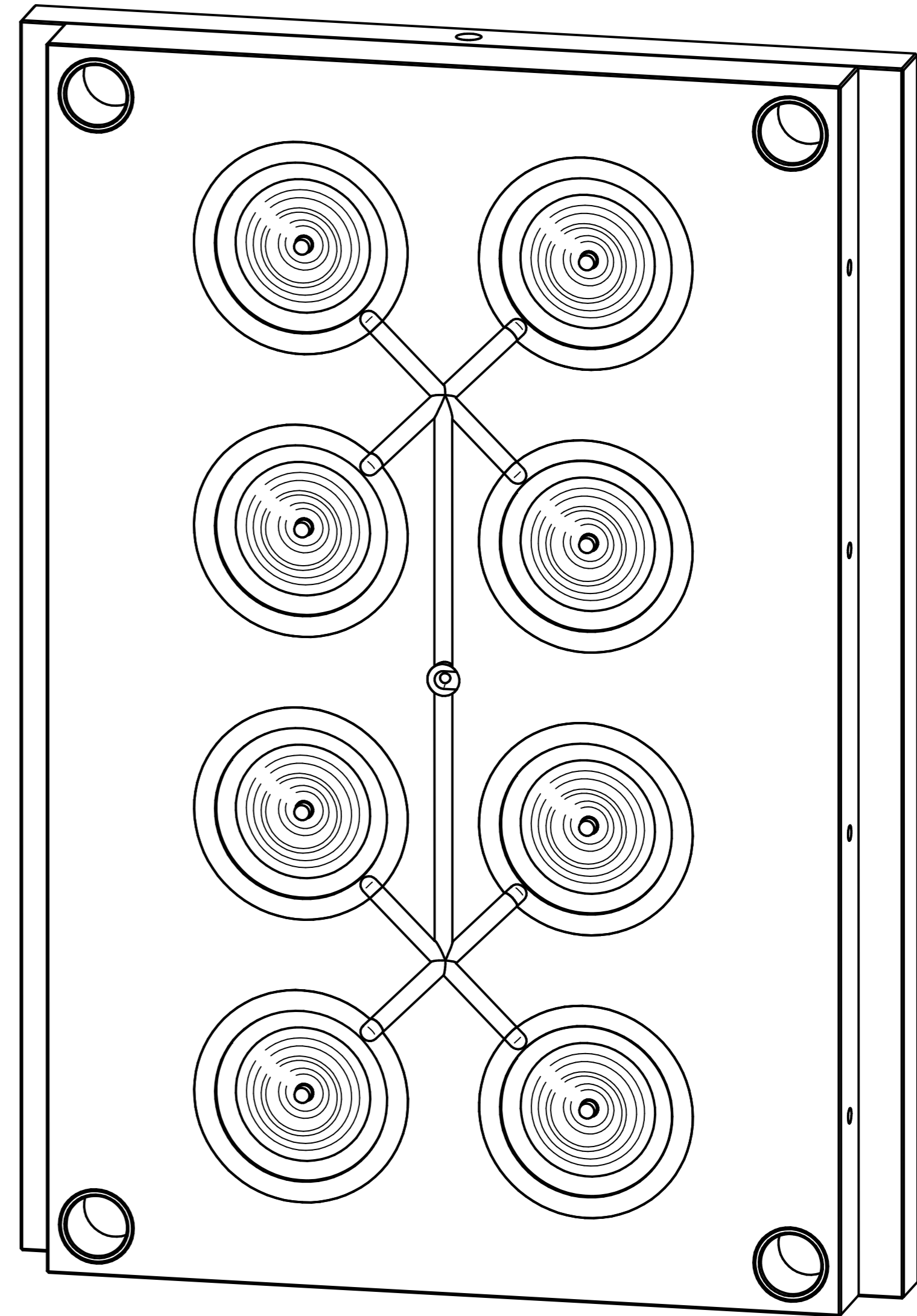
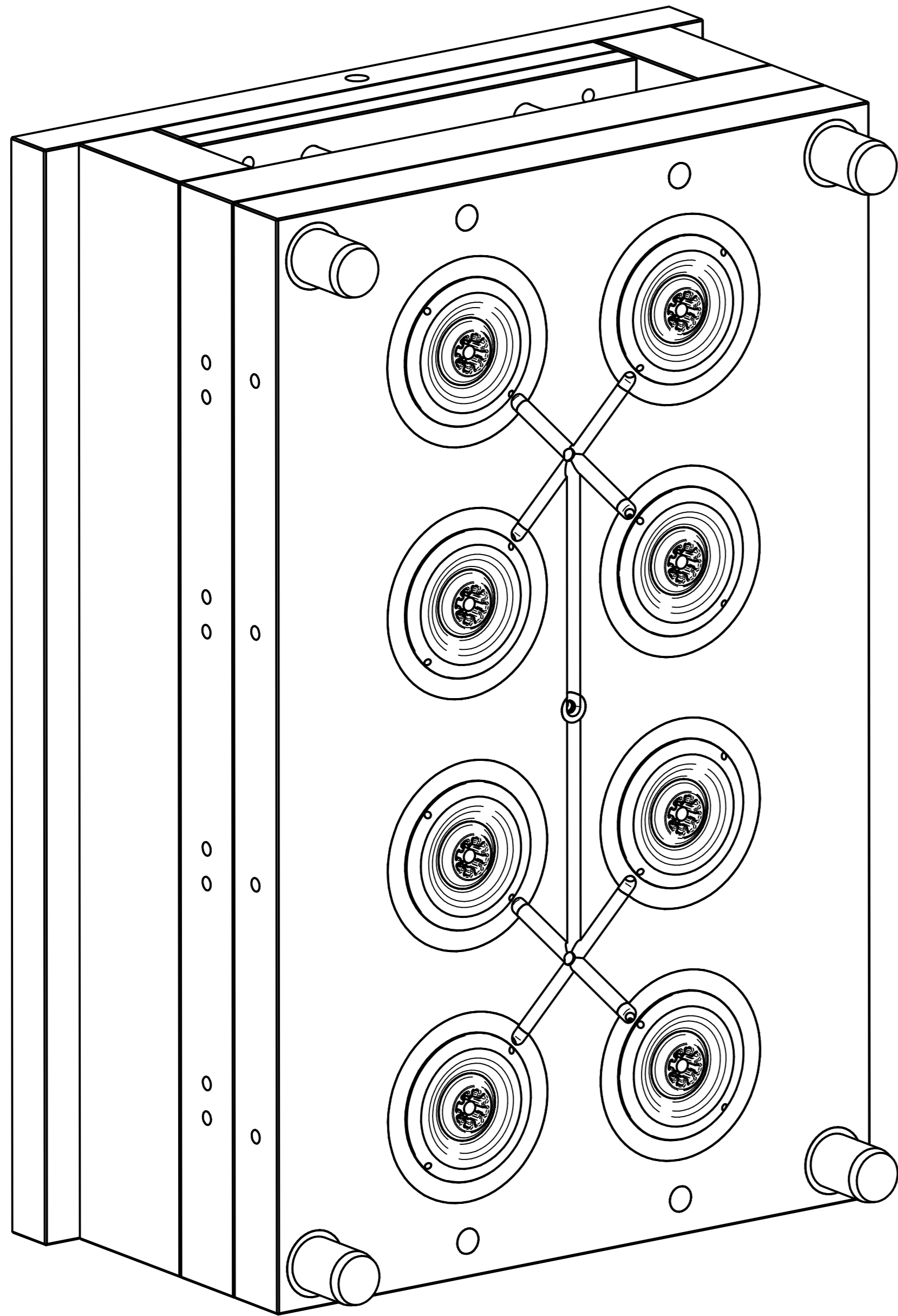

DRAWN	NAME	DATE	PREMAC		
APPROVED	Dan	05/22/18			
MATERIAL					
TREATMENT					
UNLESS OTHERWISE SPECIFIED DIMENSIONS ARE IN MILLIMETERS ANGLES ±0.1°			SIZE A4	DWG NO	REV
1st ANGLE 2 PL ±0.02 3 PL ±0.005			FILE NAME: PJP125X32 WC-ND Thread Guard Mould.dff		
SCALE:			WEIGHT:	SHEET 2 OF 7	

REVISION HISTORY			
REV	DESCRIPTION	DATE	APPROVED

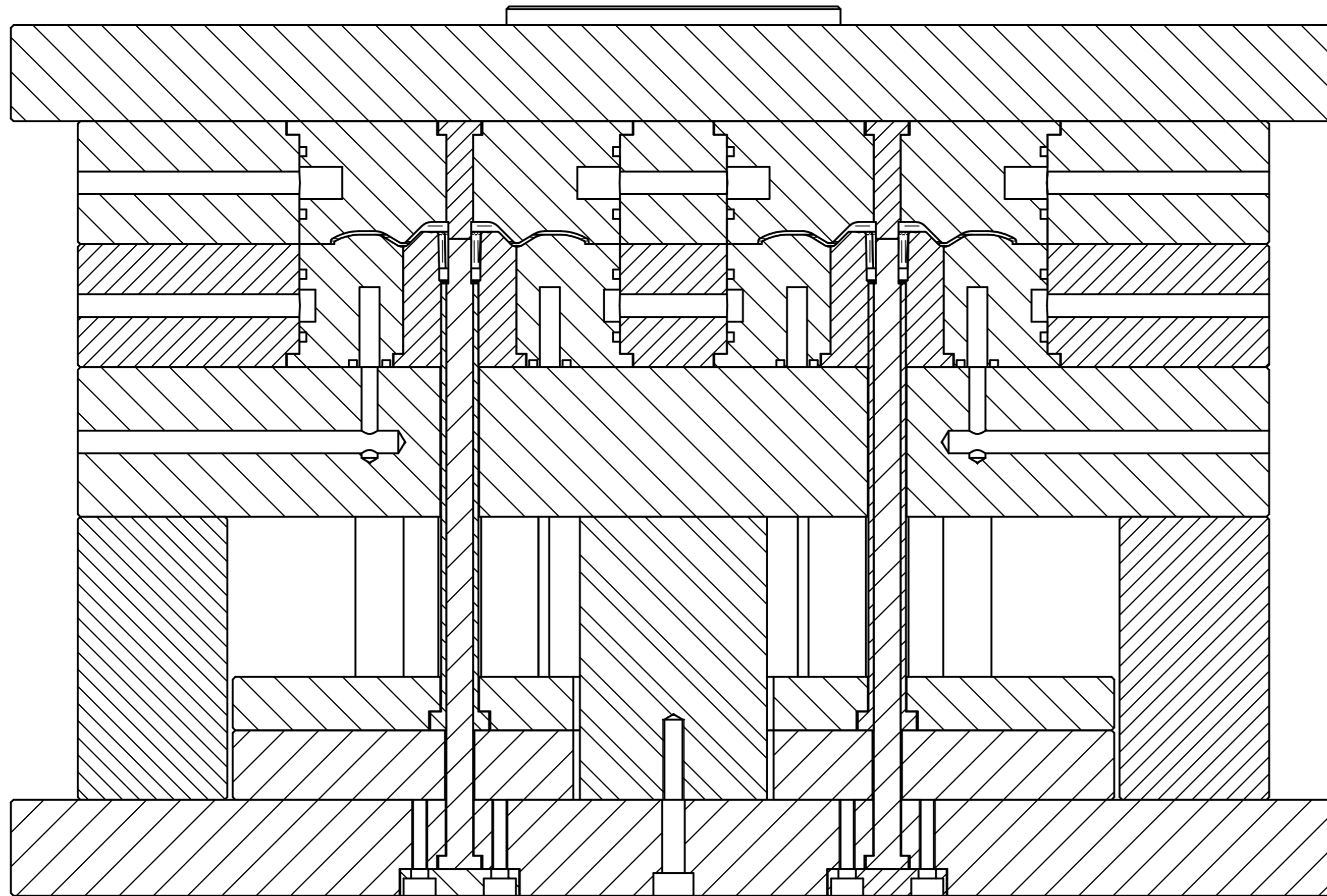

	NAME	DATE	PREMAC	
DRAWN	Dan	05/22/18		
APPROVED				
MATERIAL				
TREATMENT			TITLE	
UNLESS OTHERWISE SPECIFIED DIMENSIONS ARE IN MILLIMETERS			SIZE A4	DWG NO
1 ST ANGLE ANGLES ±0.1°			FILE NAME: PJP125X32 WC-ND Thread Guard Mould.dff	REV
2 PL ±0.02 3 PL ±0.005			SCALE:	WEIGHT:
			SHEET 3 OF 7	

REVISION HISTORY			
REV	DESCRIPTION	DATE	APPROVED

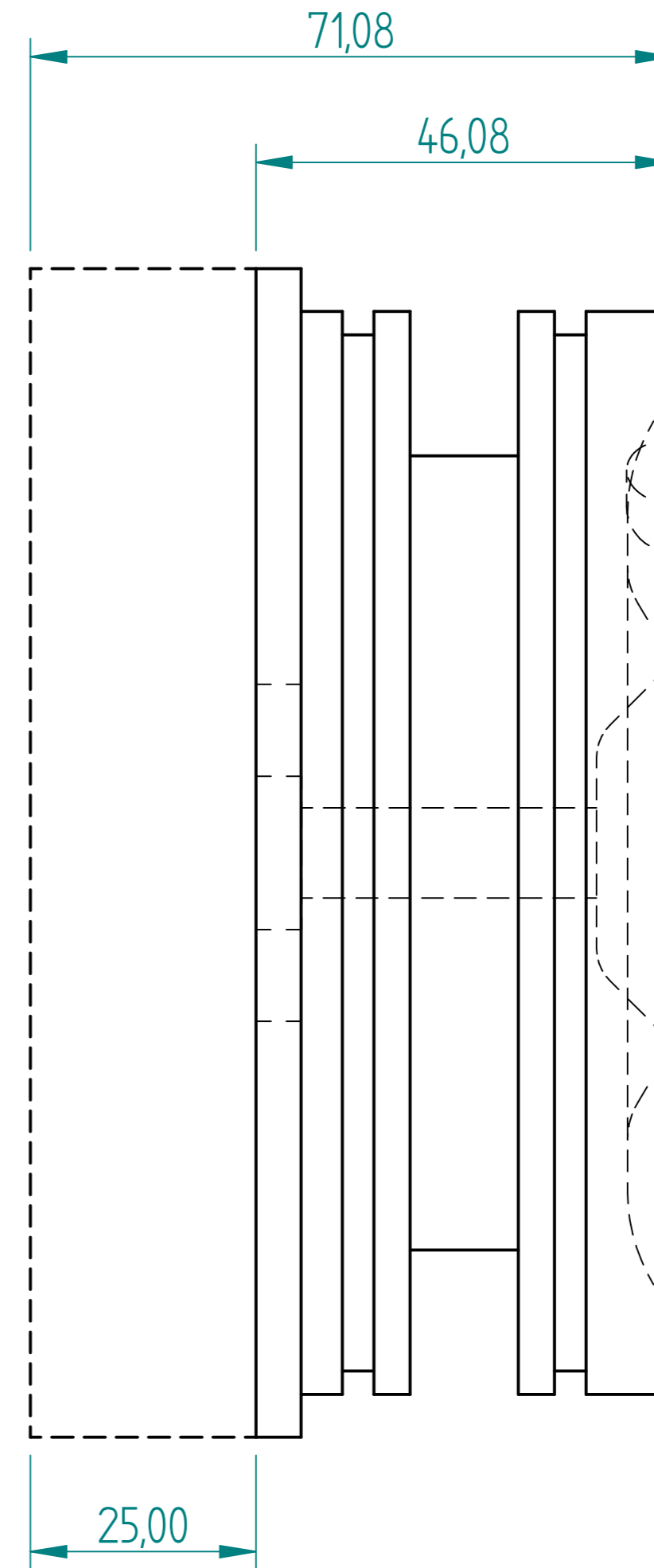
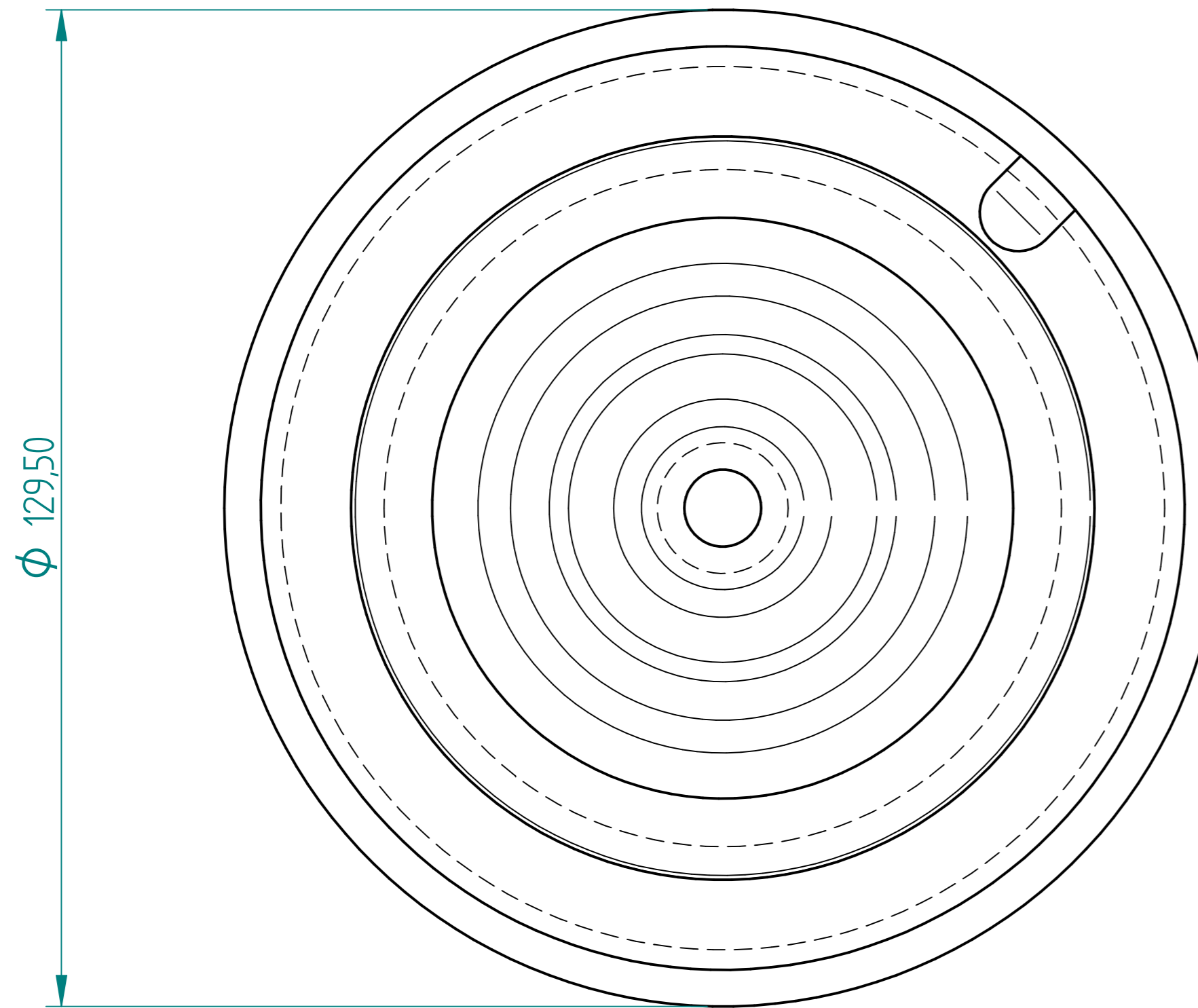

FH TG Outer Insert
 No front profile or hole
 8 OFF
 R800 each

	NAME	DATE	PREMAC	
DRAWN	Dan	05/22/18		
APPROVED				
MATERIAL				
TREATMENT			TITLE	
UNLESS OTHERWISE SPECIFIED DIMENSIONS ARE IN MILLIMETERS			SIZE A4	DWG NO
1 ST ANGLE  2 PL ±0.02 3 PL ±0.005			FILE NAME: PJP125X32 WC-ND Thread Guard Mould.dff	REV
			SCALE:	WEIGHT:
			SHEET 4 OF 7	

REVISION HISTORY			
REV	DESCRIPTION	DATE	APPROVED

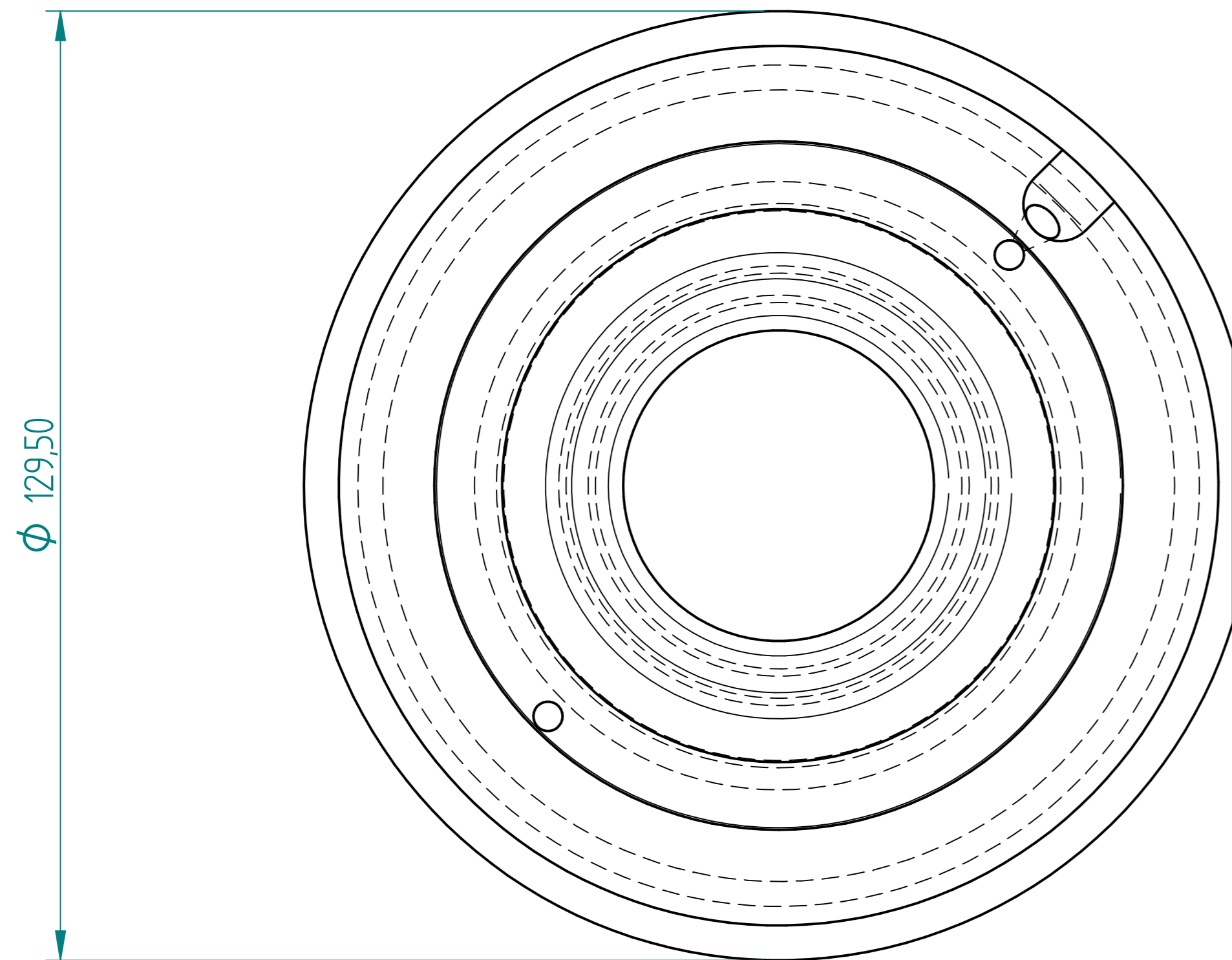

MH TG Outer Insert
8 OFF
R900 each

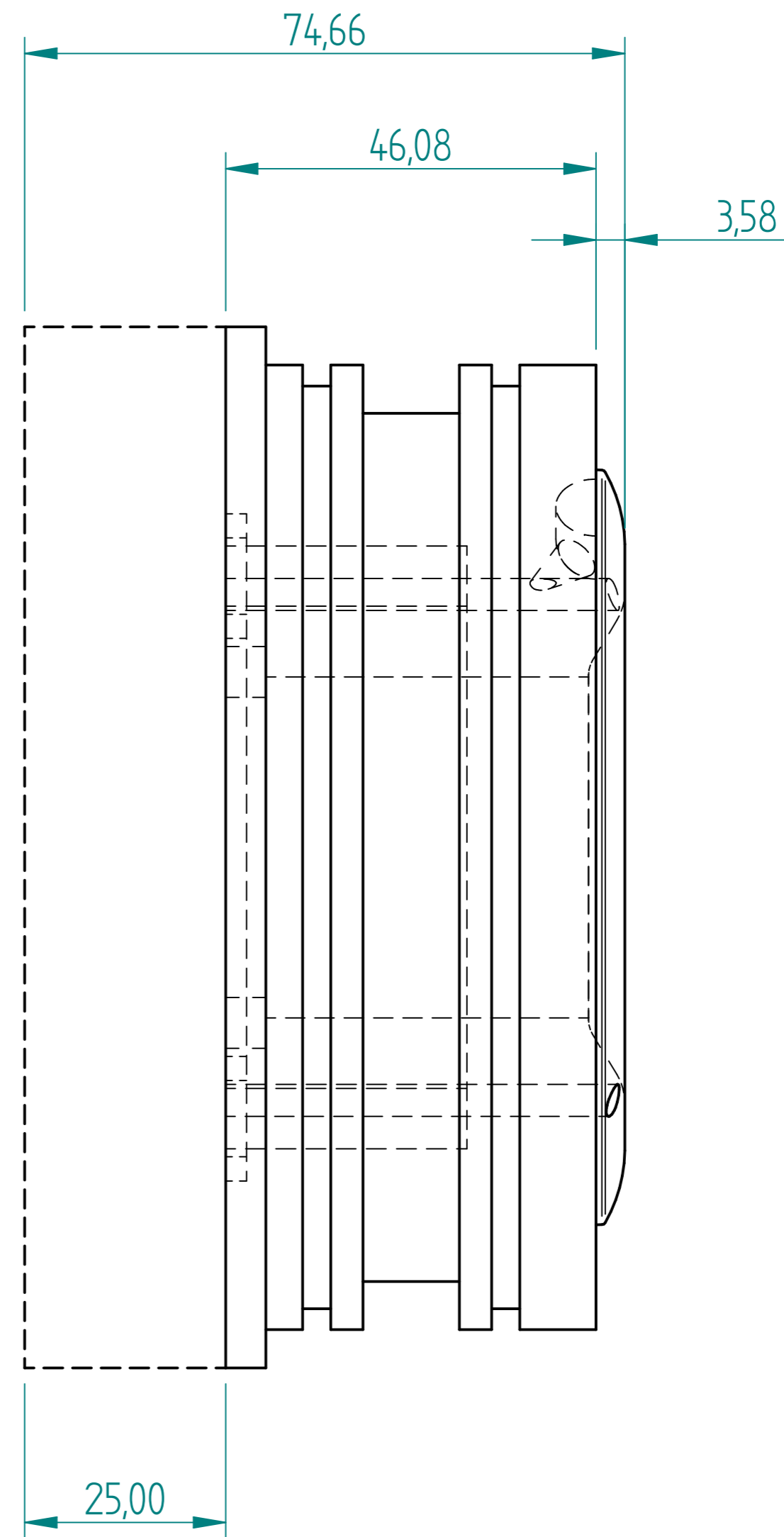

	NAME	DATE	PREMAC	
DRAWN	Dan	05/22/18		
APPROVED				
MATERIAL				
TREATMENT			TITLE	
UNLESS OTHERWISE SPECIFIED DIMENSIONS ARE IN MILLIMETERS			SIZE A4	DWG NO
1st ANGLE ANGLES $\pm 0.1^\circ$			FILE NAME: PJP125X32 WC-ND Thread Guard Mould.dff	REV
2 PL ± 0.02 3 PL ± 0.005			SCALE:	WEIGHT:
			SHEET 5 OF 7	

REVISION HISTORY			
REV	DESCRIPTION	DATE	APPROVED

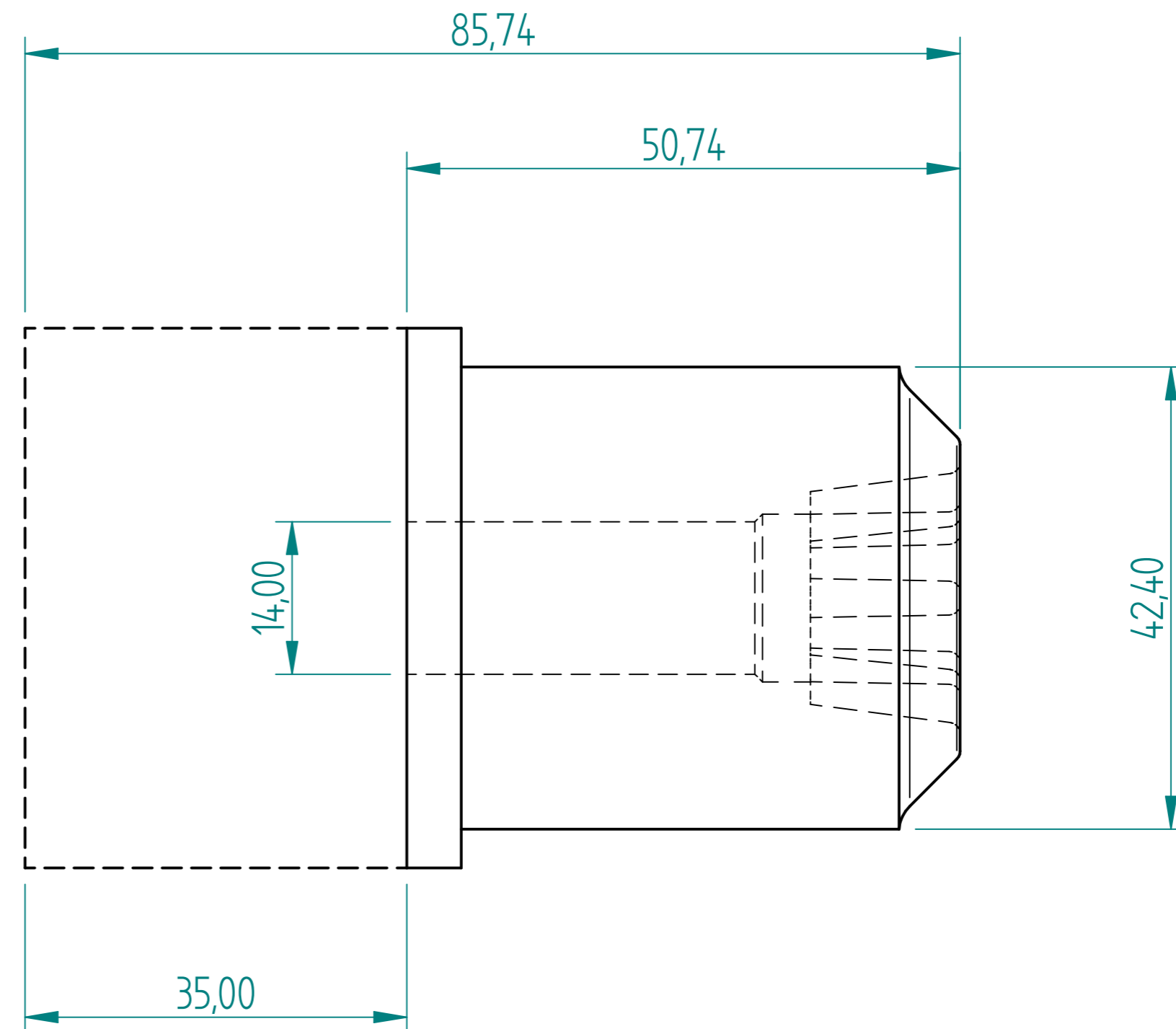
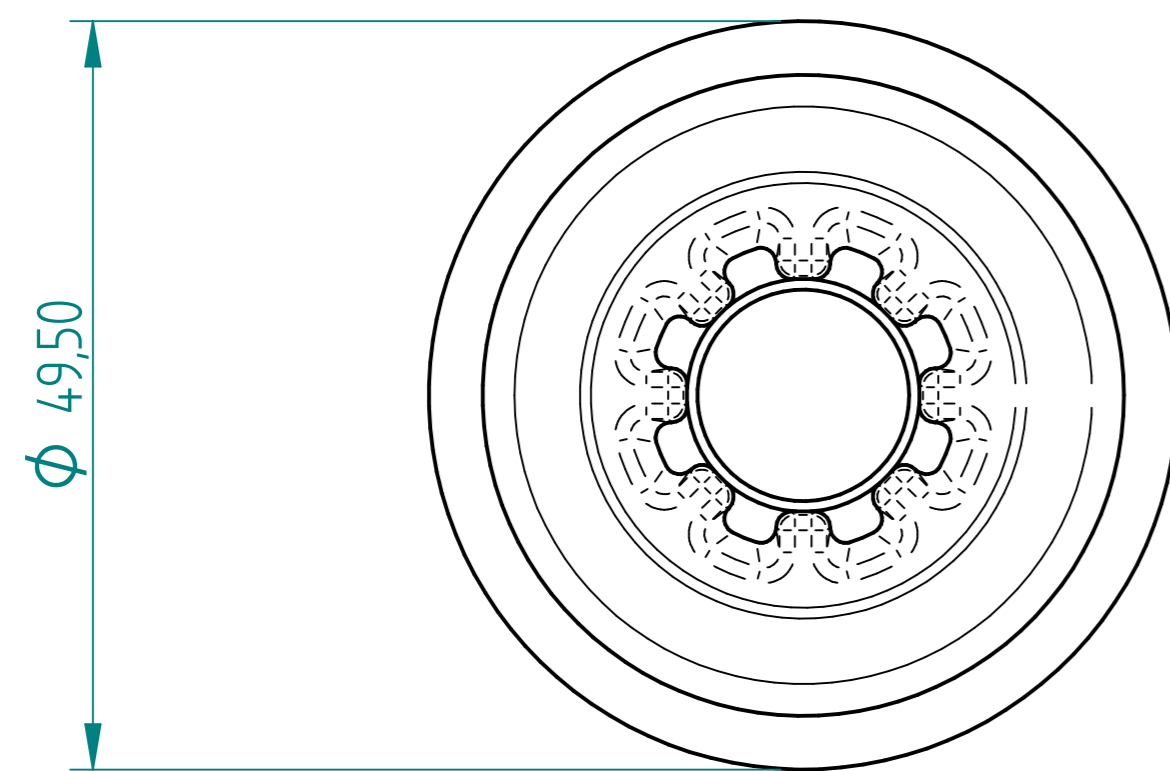

MH TG Inner Insert
 8 OFF
 Pre-Drilled Dia 12
 R350 each

	NAME	DATE	PREMAC		
DRAWN	Dan	05/22/18			
APPROVED			TITLE		
MATERIAL					
TREATMENT			SIZE A4 DWG NO. REV FILE NAME: PJP125X32 WC-ND Thread Guard Mould.dff		
UNLESS OTHERWISE SPECIFIED DIMENSIONS ARE IN MILLIMETERS ANGLES $\pm 0.1^\circ$ <small>1st ANGLE</small>					SCALE:
			2 PL ± 0.02 3 PL ± 0.005		SHEET 6 OF 7

REVISION HISTORY			
REV	DESCRIPTION	DATE	APPROVED

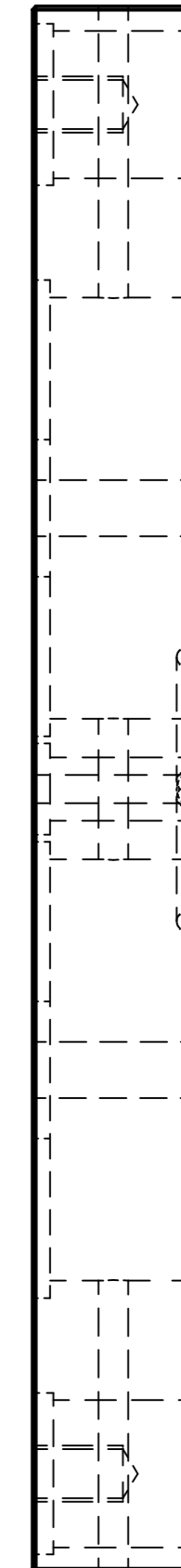
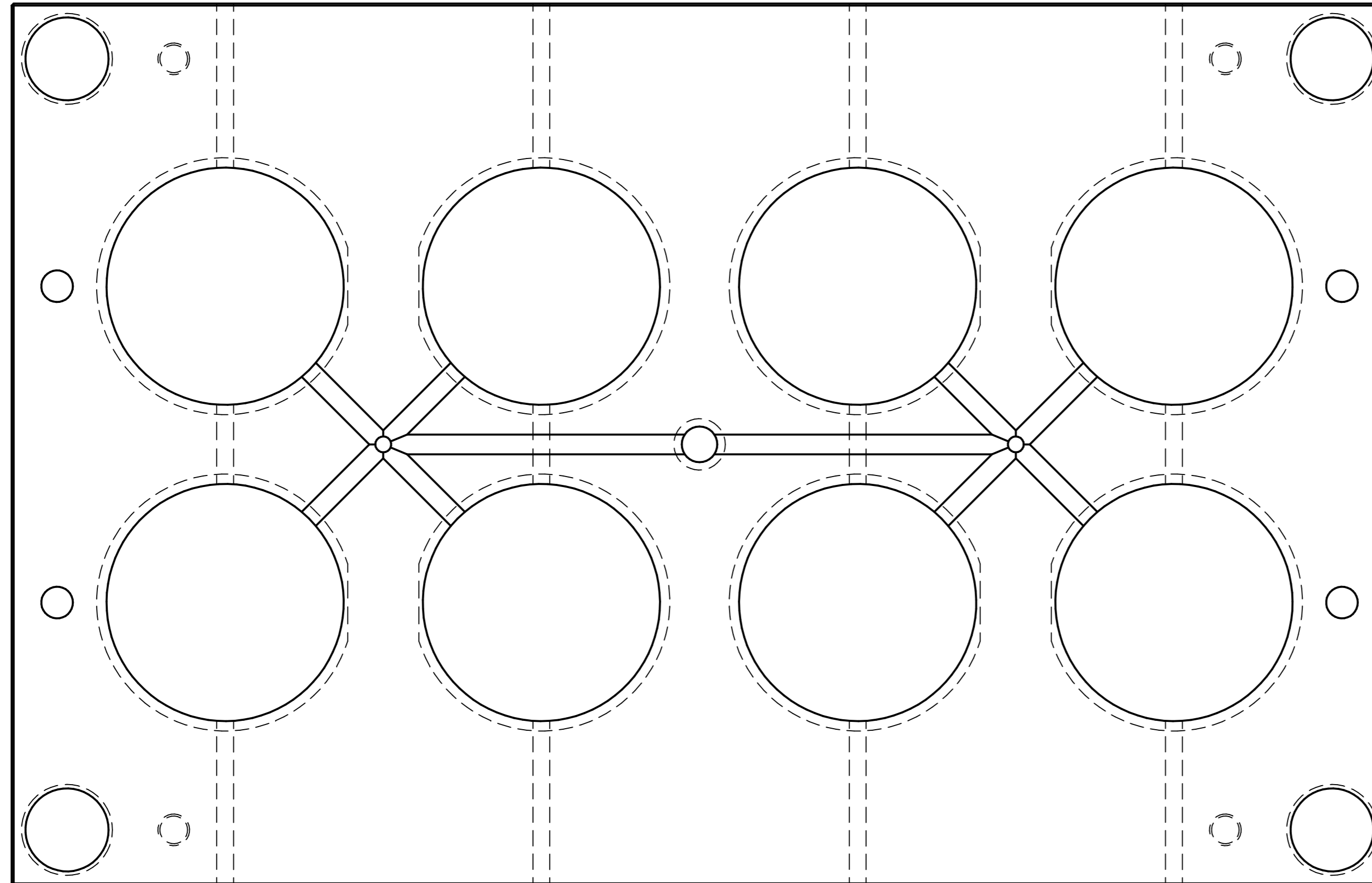

MH and FH DIE PLATES
 BOTH SIDES and WATER
 R7 000 each

	NAME	DATE	PREMAC	
DRAWN	Dan	05/22/18		
APPROVED				
MATERIAL				
TREATMENT			TITLE	
UNLESS OTHERWISE SPECIFIED DIMENSIONS ARE IN MILLIMETERS			SIZE A4	DWG NO
1st ANGLE 2 PL ±0.02 3 PL ±0.005			FILE NAME: PJP125X32 WC-ND Thread Guard Mould.dff	REV
			SCALE:	WEIGHT:
			SHEET 7 OF 7	