

REVISION HISTORY			
REV	DESCRIPTION	DATE	APPROVED

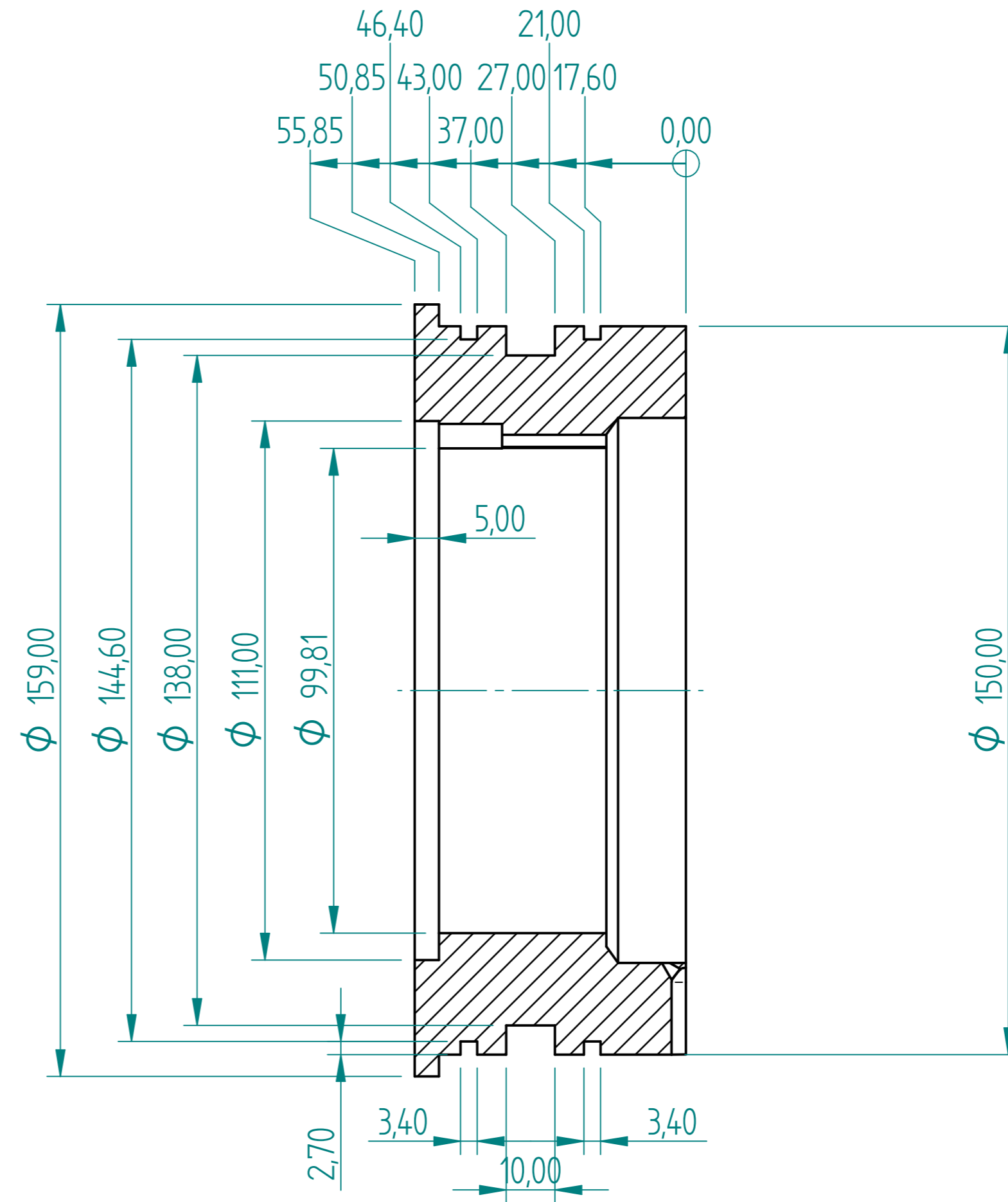
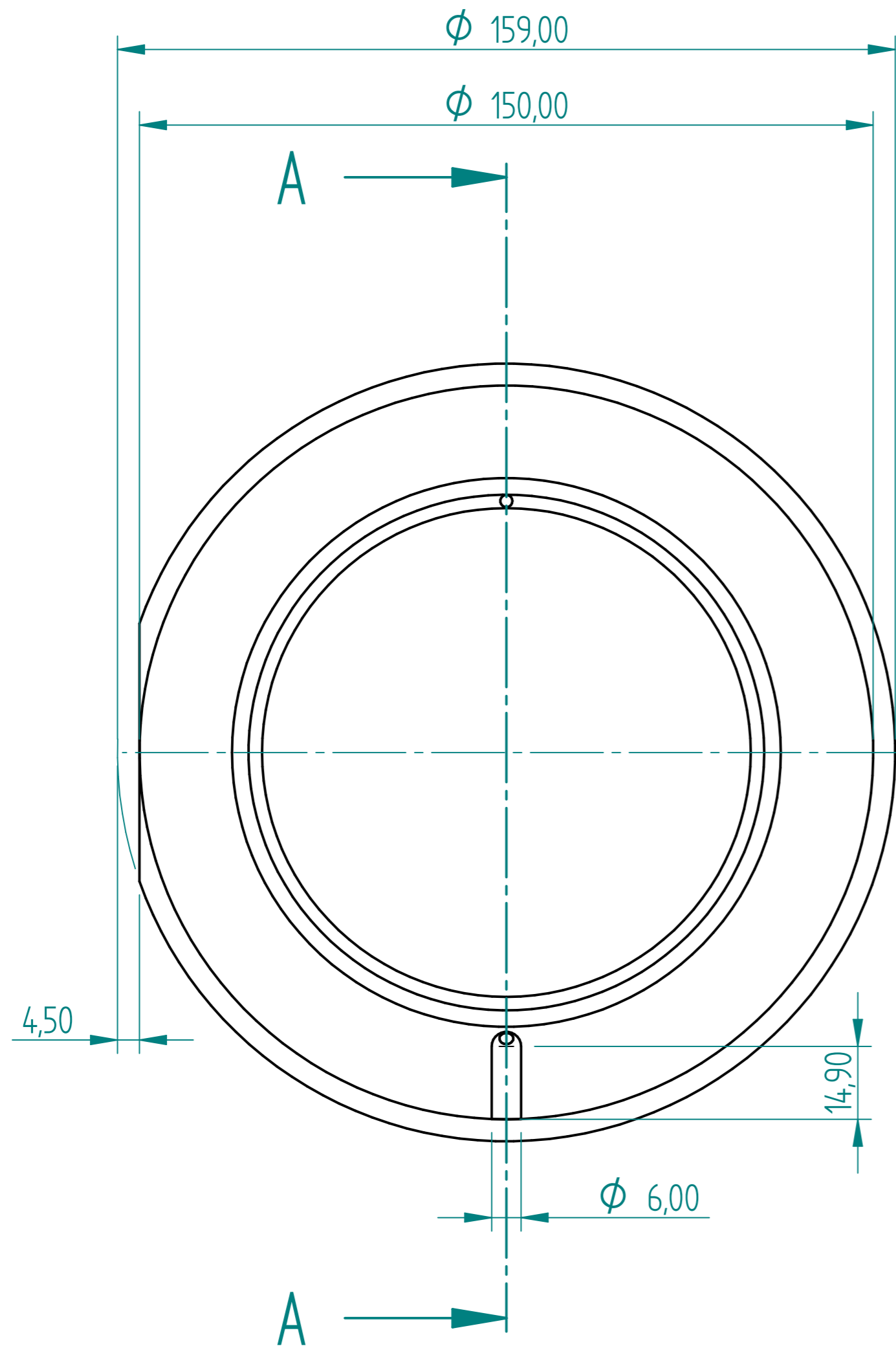

FH Insert A 16 off
+25mm

SECTION A-A

DRAWN	NAME	DATE	PREMAC	
APPROVED	Dan	11/26/19		
MATERIAL			TITLE	
TREATMENT			JP125X32H35H45 WHEEL CENTRE MOULD TURNED PARTS	
UNLESS OTHERWISE SPECIFIED DIMENSIONS ARE IN MILLIMETERS			SIZE	DWG NO
1st ANGLE ANGLES $\pm 0,1^\circ$			A4	
2 PL $\pm 0,02$ 3 PL $\pm 0,005$			FILE NAME: Turned Inserts.dft	REV
SCALE:		WEIGHT:	SHEET 1 OF 4	

REVISION HISTORY			
REV	DESCRIPTION	DATE	APPROVED

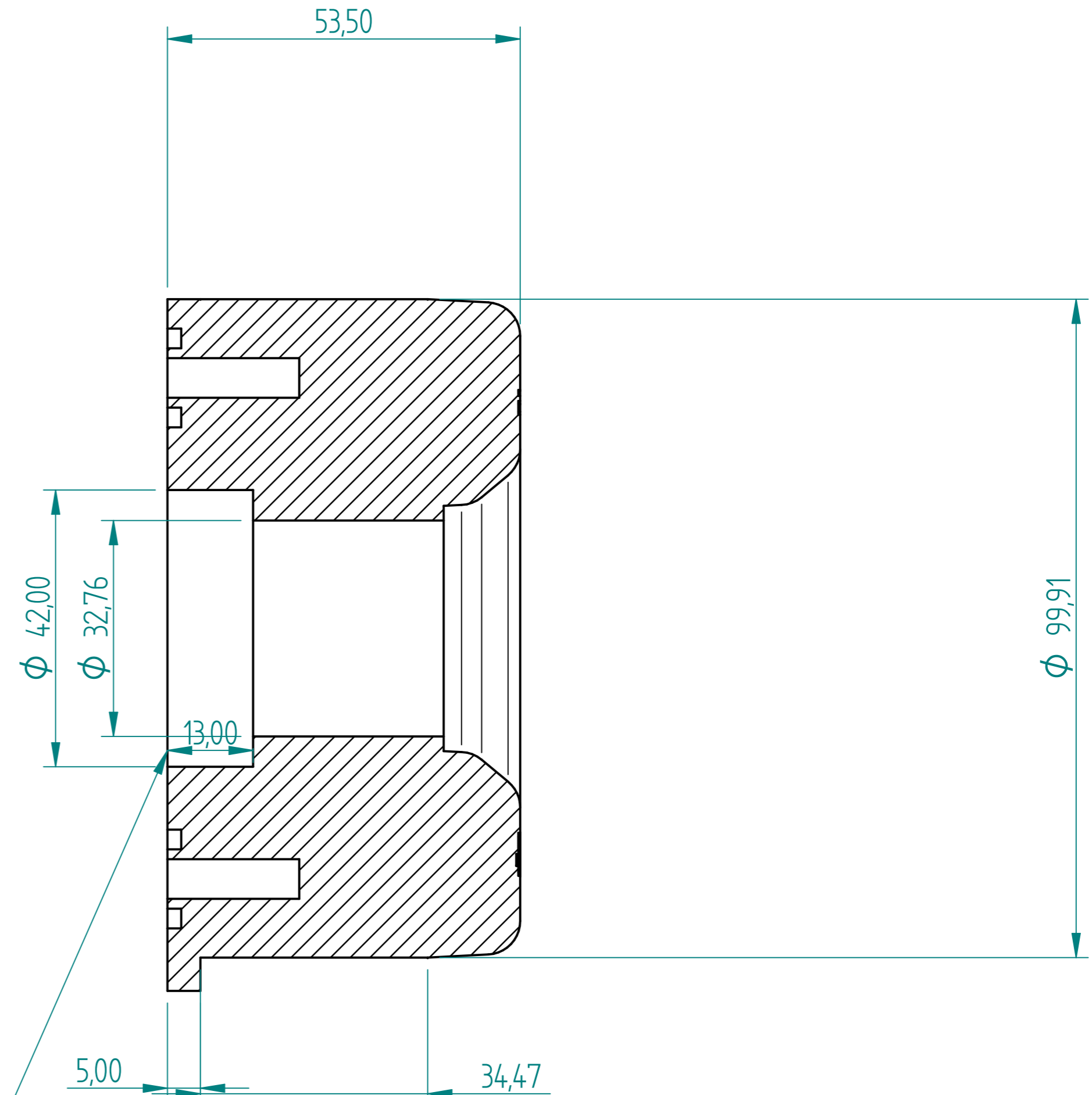
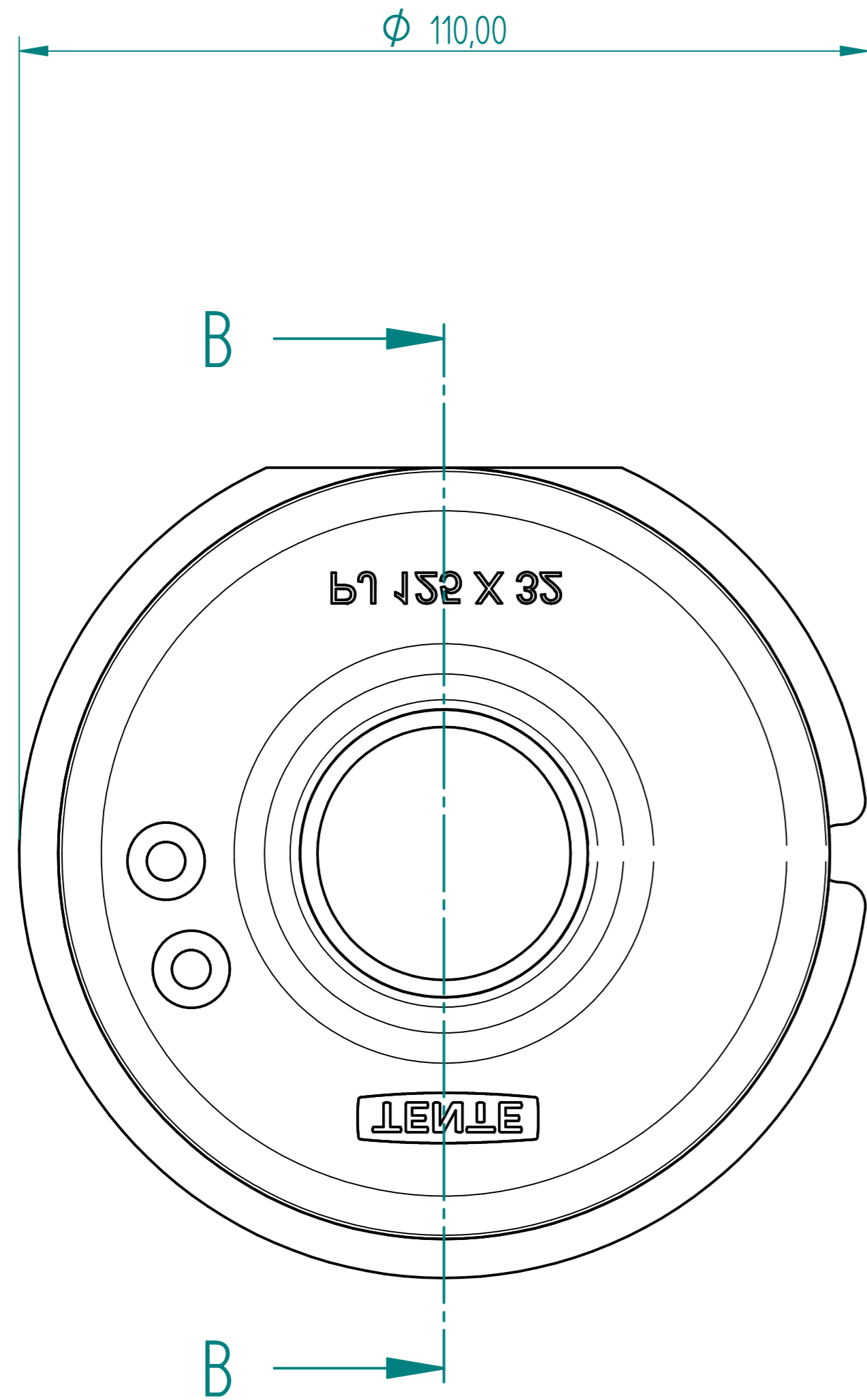

8 OFF 13mm FH
8 OFF 5.03mm MH

SECTION B-B

FH Mid Insert 16 off
+25mm

	NAME	DATE	PREMAC	
DRAWN	Dan	11/26/19		
APPROVED			TITLE	
MATERIAL			PJP125X32H35H45 WHEEL CENTRE MOULD TURNED PARTS	
TREATMENT			SIZE	DWG NO
UNLESS OTHERWISE SPECIFIED DIMENSIONS ARE IN MILLIMETERS			A4	
			FILE NAME: Turned Inserts.dft	REV
1st ANGLE			SCALE:	WEIGHT:
2 PL ±0.02 3 PL ±0.005				SHEET 2 OF 4

REVISION HISTORY			
REV	DESCRIPTION	DATE	APPROVED

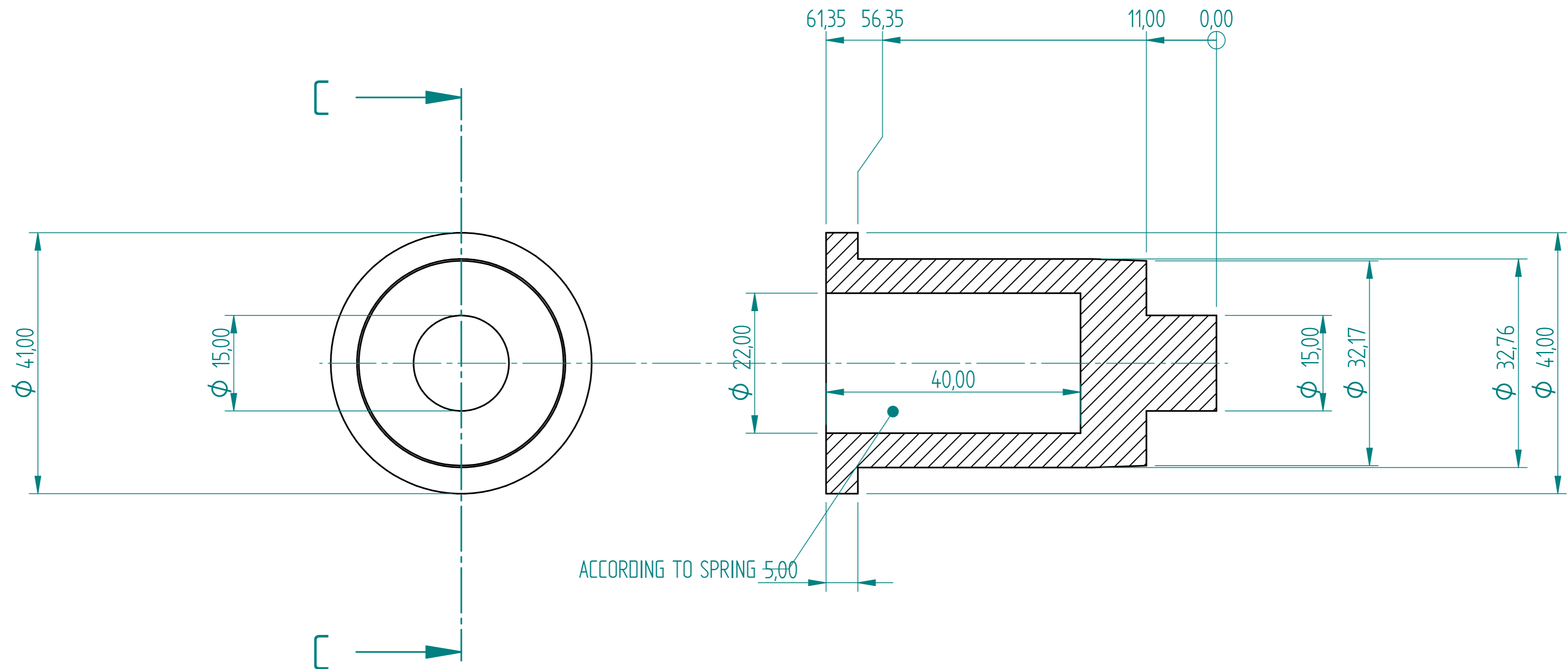

SECTION C-C

FH Inner Insert 8 OF
+35mm

	NAME	DATE	PREMAC	
DRAWN	Dan	11/26/19		
APPROVED			TITLE	
MATERIAL			PJP125X32H35H45 WHEEL CENTRE MOULD TURNED PARTS	
TREATMENT			SIZE	DWG NO
UNLESS OTHERWISE SPECIFIED DIMENSIONS ARE IN MILLIMETERS			A4	
			FILE NAME: Turned Inserts.dft	REV
1st ANGLE			SCALE:	WEIGHT:
2 PL ±0.02 3 PL ±0.005				SHEET 3 OF 4

REVISION HISTORY			
REV	DESCRIPTION	DATE	APPROVED

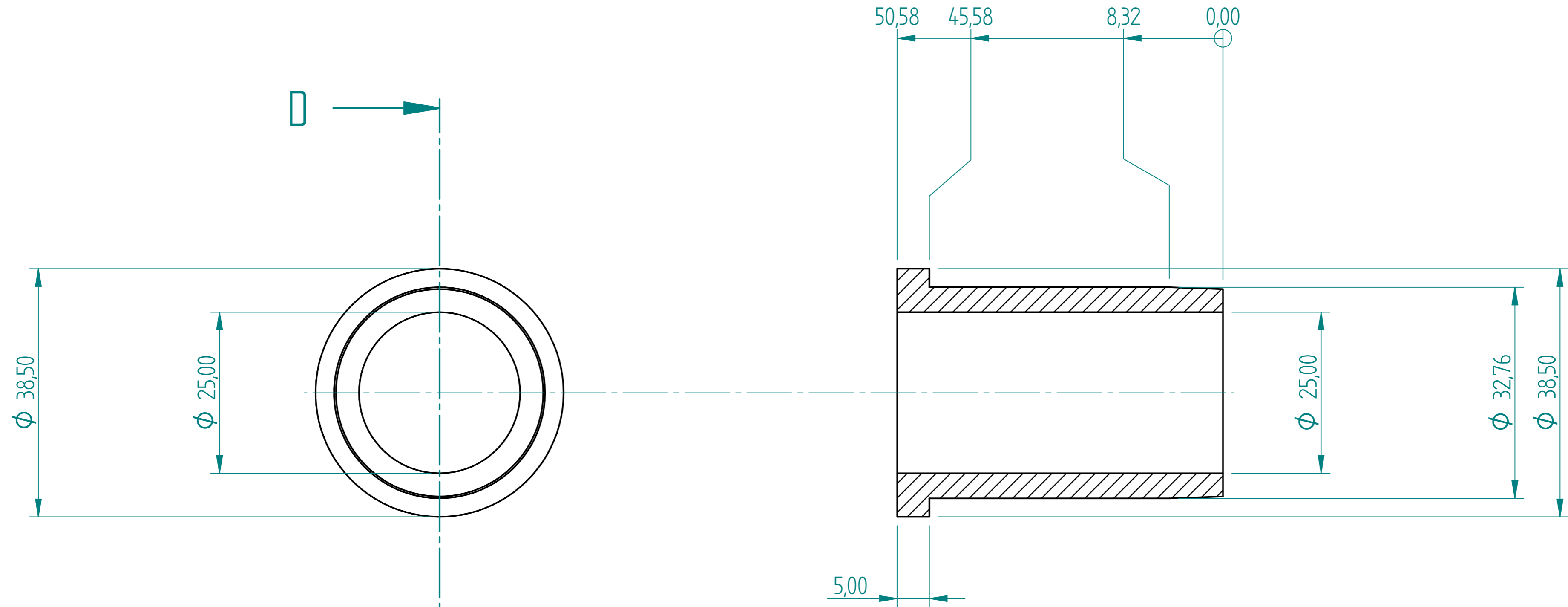

SECTION D-D

MH Inner Insert 8 OF
+35mm

	NAME	DATE	PREMAC	
DRAWN	Dan	11/26/19		
APPROVED				
MATERIAL				
TREATMENT			TITLE	
UNLESS OTHERWISE SPECIFIED DIMENSIONS ARE IN MILLIMETERS			SIZE	DWG NO
1 st ANGLE ANGLES ±0.1°			A4	
2 PL ±0.02 3 PL ±0.005			FILE NAME: Turned Inserts.dft	REV
			SCALE:	WEIGHT:
				SHEET 4 OF 4