

SCALE 1:1

NOTE:

R2 DESIGNATES 2" BRITISH PARALLEL PIPE THREAD, BSPP. DIMENSIONS ARE AS FOLLOWS:

- MAJOR DIAMETER: 59.614
- PITCH DIAMETER: 58.135
- MINOR DIAMETER: 56.656
- THREADS PER INCH: 11.

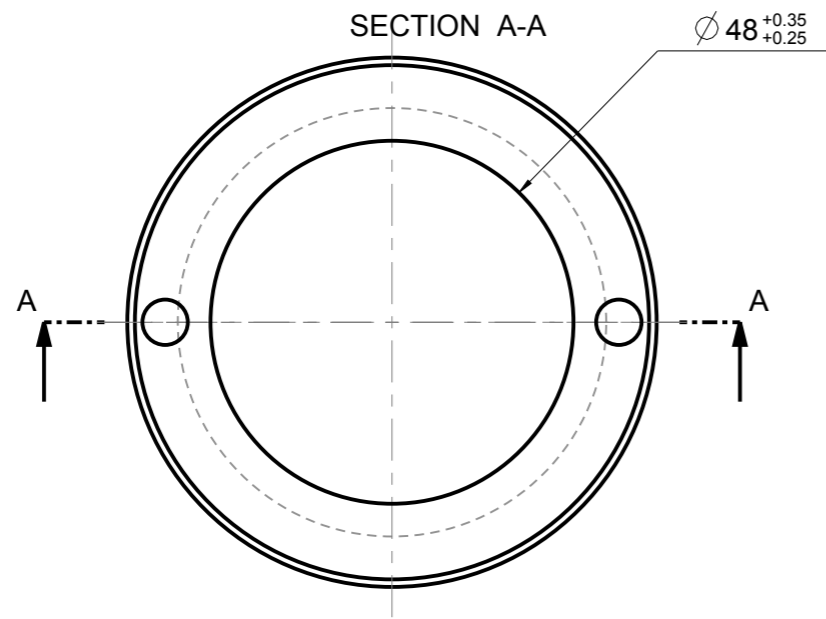

**DYNAMIC FLUID CONTROL**  
 VALID FROM  
 Nov-20-12  
 UNTIL FURTHER NOTICE  
 SIGN: *D. Calle*

© Copyright D.F.C.

<b>A3</b>	<b>Pro/E</b>
PINCH VALVE In Work	
MACHINING SYMBOLS TO ISO STANDARDS	
CASTING TOLERANCES UNLESS OTHERWISE SPECIFIED mm UNITS	MACHINING TOLERANCES UNLESS OTHERWISE SPECIFIED mm UNITS
UP TO 75 ± 1.0	UP TO 120 ± 0.3
OVER 75 UP TO 150 ± 1.5	OVER 120 UP TO 300 ± 0.5
OVER 150 UP TO 250 ± 2.0	OVER 300 UP TO 1000 ± 0.8
OVER 250 UP TO 500 ± 3.0	OVER 1000 ± 1.2
OVER 500 ± 4.0	ANGLES ± 0.1
ANGLES ± 1.0	DRILLED HOLES ± 0.1

1	0	70 DIA ROUND POM BLACK	ZMR07000PPOM	POLYACETAL
ITEM	QTY	DESCRIPTION	PART CODE	MATERIAL
REV. A	DATE: 16-Oct-12 02:14:04 PM	DONE BY:		
		32 Lincoln Road, Benoni South P.O. BOX 5064, Benoni South, 1502, Gauteng, South Africa Tel: +27 11 748 0200 Fax: +27 11 421 2749		
THIS DRAWING AND DESIGN IS THE PROPERTY OF DYNAMIC FLUID CONTROL AND MUST NOT BE COPIED OR DISCLOSED TO ANY THIRD PARTY WITHOUT THE CONSENT OF THE COMPANY IN WRITING AND TO BE RETURNED UPON REQUEST.		SCALE: NTS	NAME	DATE
		DRAWN	Calldo, Dennis	20-Jul-12 10:56:00 AM
		CHECKED	Calldo, Dennis	16-Oct-12 02:14:04 PM
TITLE: G 2 X 48.3 CENTER BUSH			DRAWING No: / MODLE No: <b>BEBB048CMBPPOM</b>	
			SHEET 1 OF 1	