

REVISION HISTORY			
REV	DESCRIPTION	DATE	APPROVED

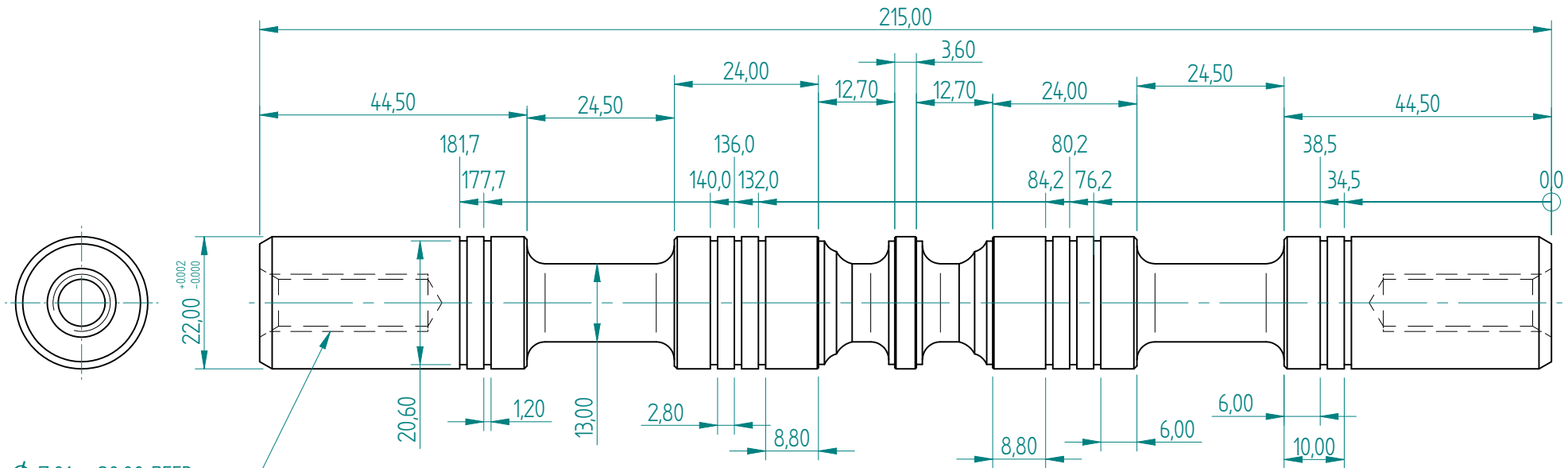

ϕ 7,81 - 28,00 DEEP
 C'SINK ϕ 11,43 X 60,0°
 3/8-16 UNC - 28,00 DEEP

TURN DIA 22.2
 PRE-GRIND DIA 21.9
 HARD CHROME DIA 22.2
 FINAL GRIND DIA 22.0

DRAWN	NAME	DATE	PREMAC	
APPROVED	Dan	06/01/10	PRECISION MACHINE MANUFACTURERS (PTY)LTD.	
MATERIAL			TITLE	
TREATMENT			V150 Std Spool	
UNLESS OTHERWISE SPECIFIED DIMENSIONS ARE IN MILLIMETERS ANGLES $\pm 0,1^\circ$			SIZE A2	DWG NO
2 PL $\pm 0,02$ 3 PL $\pm 0,005$			FILE NAME: V150 Std Spool.dft	REV
			SCALE:	WEIGHT:
			SHEET 1 OF 1	