

Item Number	Document Number	Title	Quantity
1		Adjster Poppet	1
2		Adjuster Housing	1
3		Housing	1
4		Poppet	1
5		Spring	1

REVISION HISTORY			
REV	DESCRIPTION	DATE	APPROVED

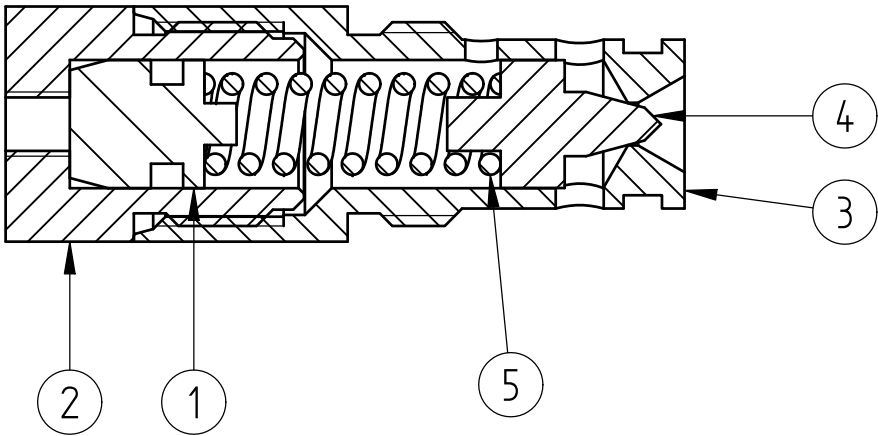
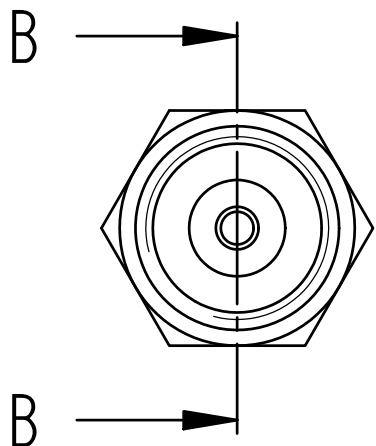

SECTION B-B

DRAWN		NAME	DATE	<b>PREMAC</b> PRECISION MACHINE MANUFACTURERS (PTY)LTD. TITLE <b>V45 POPPET RELIEF</b>	
APPROVED					
MATERIAL					
TREATMENT					
UNLESS OTHERWISE SPECIFIED DIMENSIONS ARE IN MILLIMETERS ANGLES ±0.1° 1 ST ANGLE				SIZE	REV
				A3	
2 PL ±0.02 3 PL ±0.005				FILE NAME: Relief Poppet.dft	
SCALE:		WEIGHT:		SHEET 1 OF 6	

REVISION HISTORY			
REV	DESCRIPTION	DATE	APPROVED

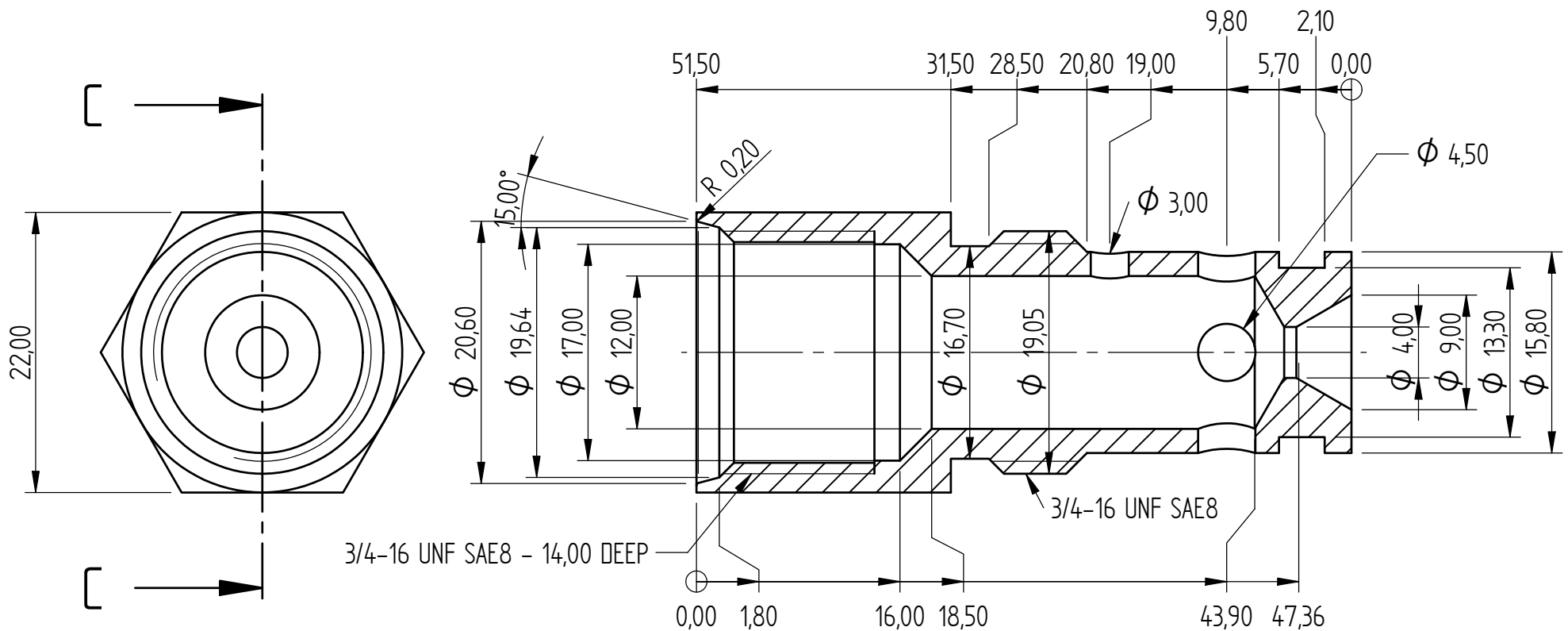

SECTION C-C

Housing

	NAME	DATE	PREMAC	
DRAWN	Dan	06/01/10		
APPROVED			TITLE	
MATERIAL			V45 POPPET RELIEF	
TREATMENT			SIZE	DWG NO
UNLESS OTHERWISE SPECIFIED DIMENSIONS ARE IN MILLIMETERS ANGLES ±0.1°			A3	REV
			FILE NAME: Relief Poppet.dft	
1st ANGLE 2 PL ±0.02 3 PL ±0.005			SCALE:	WEIGHT:
			SHEET 2 OF 6	

REVISION HISTORY

REV	DESCRIPTION	DATE	APPROVED

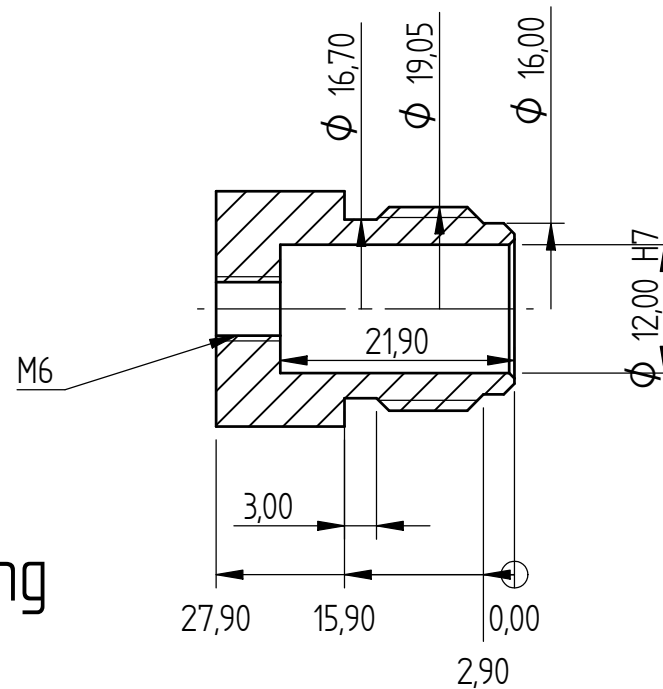
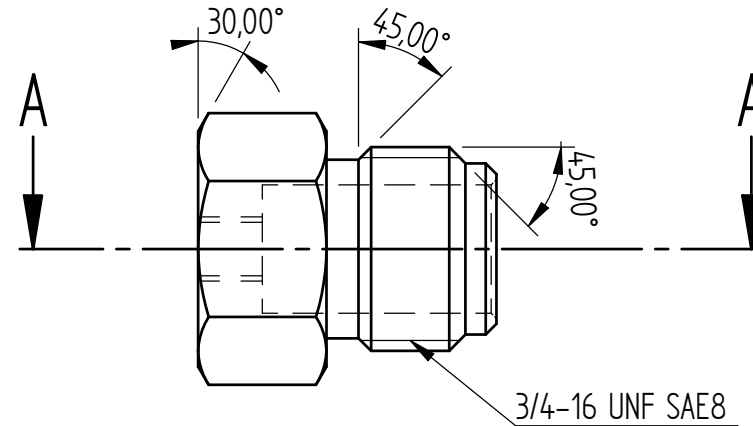
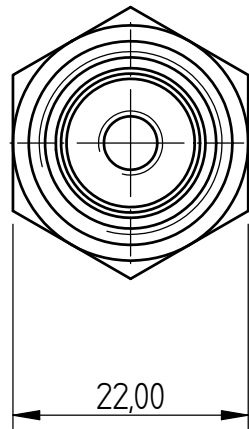

Adjuster Housing

SECTION A-A

	NAME	DATE	PREMAC	
DRAWN	Dan	06/01/10		
APPROVED			TITLE	
MATERIAL			V45 POPPET RELIEF	
TREATMENT			SIZE	DWG NO
UNLESS OTHERWISE SPECIFIED DIMENSIONS ARE IN MILLIMETERS ANGLES ±0.1°			A3	REV
			FILE NAME: Relief Poppet.dft	
1st ANGLE			SCALE:	WEIGHT:
2 PL ±0.02 3 PL ±0.005			SHEET 3 OF 6	

REVISION HISTORY			
REV	DESCRIPTION	DATE	APPROVED

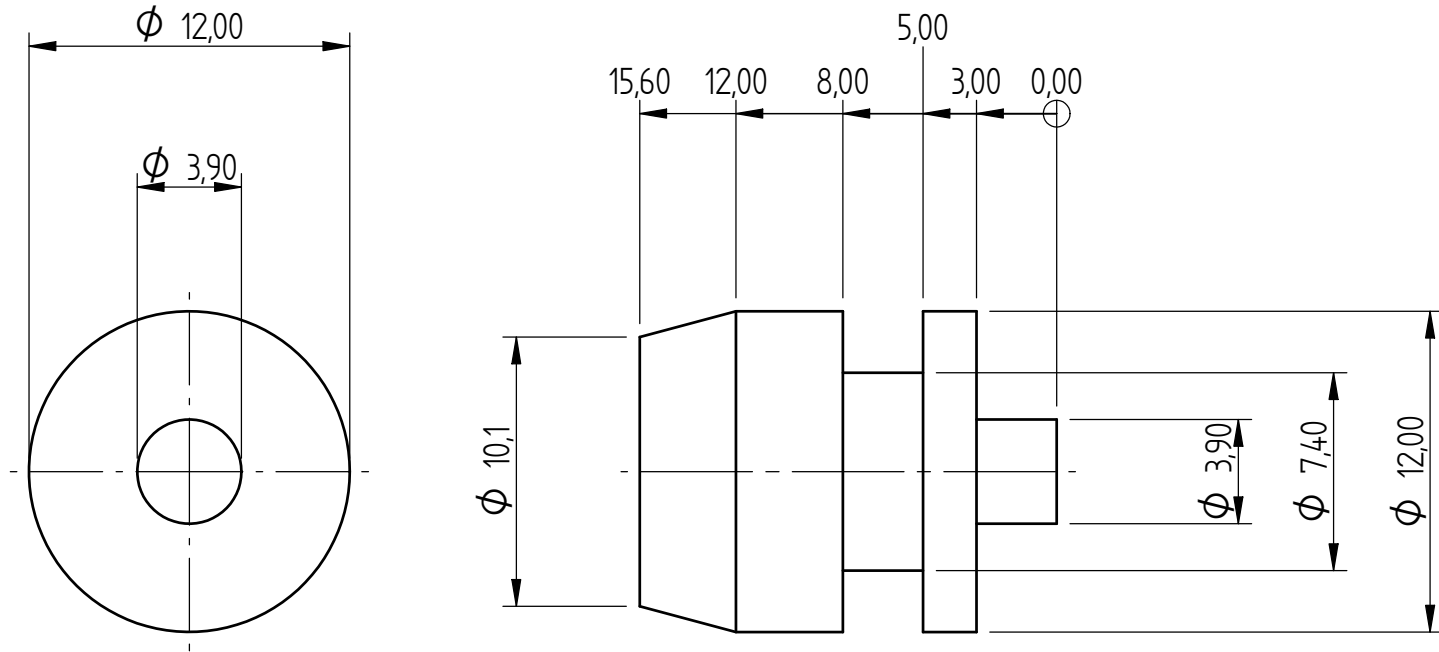

# Adjster Poppet

	NAME	DATE	PREMAC	
DRAWN	Dan	06/01/10		
APPROVED			TITLE	
MATERIAL			V45 POPPET RELIEF	
TREATMENT			SIZE	DWG NO
UNLESS OTHERWISE SPECIFIED DIMENSIONS ARE IN MILLIMETERS ANGLES $\pm 0,1^\circ$			A3	REV
			FILE NAME: Relief Poppet.dft	
$\frac{1}{1}$ OF ANGLE 			SCALE:	WEIGHT:
			SHEET 4 OF 6	

REVISION HISTORY			
REV	DESCRIPTION	DATE	APPROVED

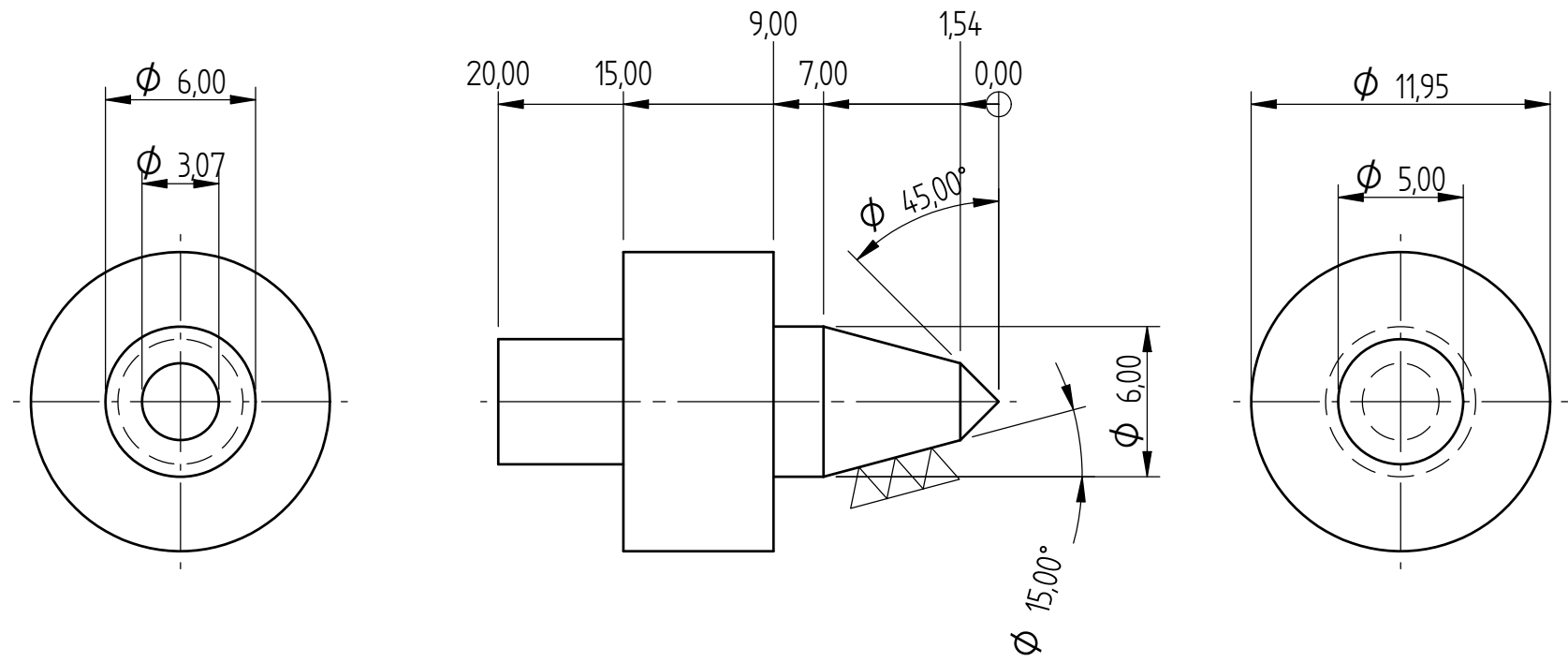

LEAVE 0.5mm FOR GRINDING ON SEATING SURFACE

# Poppet

	NAME	DATE	<b>PREMAC</b>		
DRAWN	Dan	06/01/10			PRECISION MACHINE MANUFACTURERS (PTY)LTD.
APPROVED			TITLE		
MATERIAL			V45 POPPET RELIEF		
TREATMENT					
UNLESS OTHERWISE SPECIFIED DIMENSIONS ARE IN MILLIMETERS ANGLES $\pm 0.1^\circ$			SIZE	DWG NO	REV
			A3		
<sup>1</sup> OF ANGLE 			FILE NAME: Relief Poppet.dft		
			SCALE:	WEIGHT:	SHEET 5 OF 6
2 PL $\pm 0.02$ 3 PL $\pm 0.005$					

REVISION HISTORY			
REV	DESCRIPTION	DATE	APPROVED

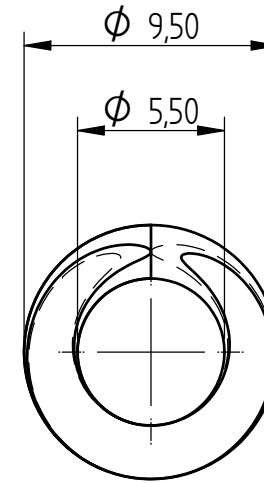
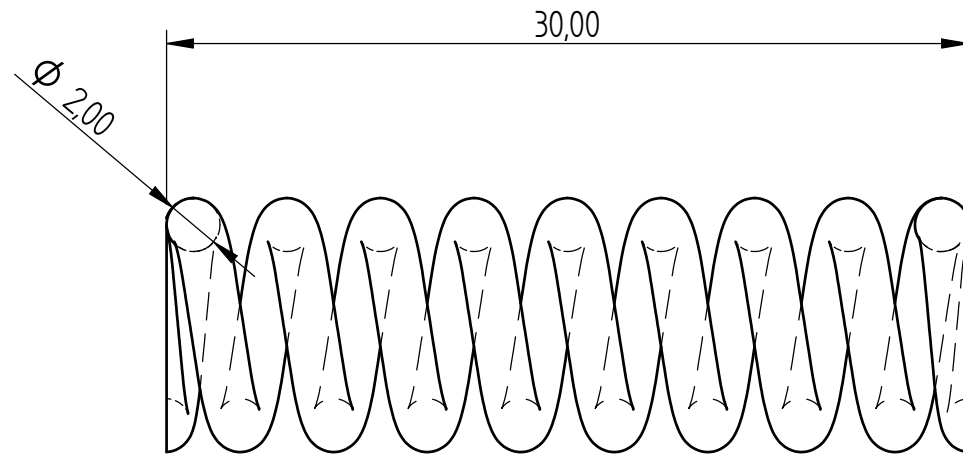

## V45 RELIEF SPRING

10 WORKING COILS & 2 END COILS GROUND FLAT

	NAME	DATE	PREMAC	
DRAWN	Dan	06/01/10		
APPROVED			TITLE	
MATERIAL			V45 POPPET RELIEF	
TREATMENT			SIZE	DWG NO
UNLESS OTHERWISE SPECIFIED DIMENSIONS ARE IN MILLIMETERS ANGLES $\pm 0.1^\circ$			A3	REV
			FILE NAME: Relief Poppet.dft	
$\frac{1}{16}$ OF ANGLE 			SCALE:	WEIGHT:
2 PL $\pm 0.02$ 3 PL $\pm 0.005$			SHEET 6 OF 6	