

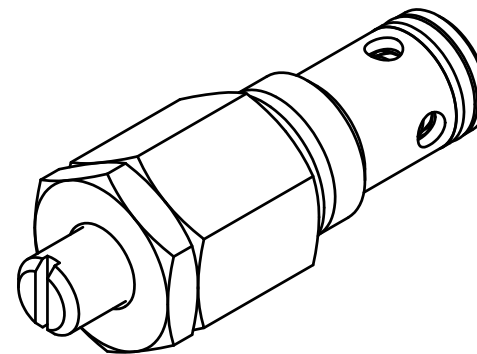

REVISION HISTORY			
REV	DESCRIPTION	DATE	APPROVED

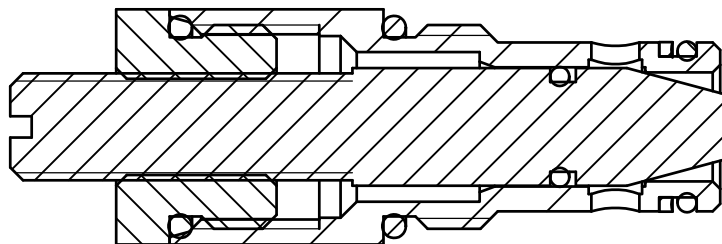
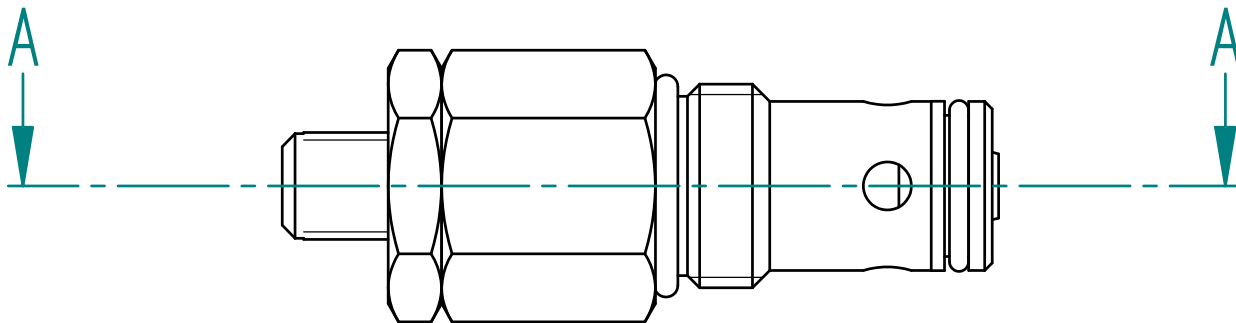

SECTION A-A

	NAME	DATE	PREMAC PRECISION MACHINE MANUFACTURERS (PTY)LTD.	
DRAWN	D.L.G.	06/01/10		
APPROVED			TITLE Accumulator Release Cartridge	
MATERIAL				SIZE A3
TREATMENT				DWG NO
UNLESS OTHERWISE SPECIFIED DIMENSIONS ARE IN MILLIMETERS ANGLES ±0.1°			REV	
			FILE NAME: Release Cartridge.dft	
1st ANGLE 			SCALE:	WEIGHT:
2 PL ±0.02 3 PL ±0.005			SHEET 1 OF 3	

REVISION HISTORY			
REV	DESCRIPTION	DATE	APPROVED

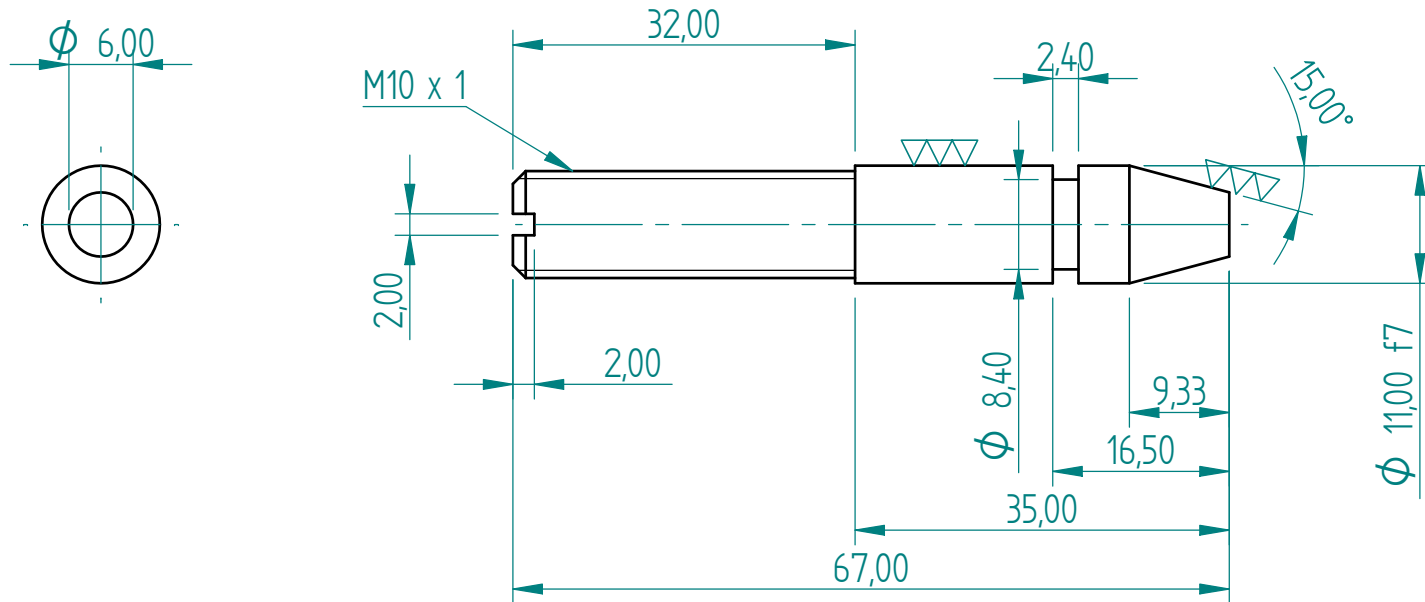

ACCUMULATOR RELEASE PISTON

	NAME	DATE	PREMAC		
DRAWN	D.L.G.	06/01/10			
APPROVED			PRECISION MACHINE MANUFACTURERS (PTY)LTD.		
MATERIAL			TITLE		
TREATMENT			Accumulator Release Cartridge		
UNLESS OTHERWISE SPECIFIED DIMENSIONS ARE IN MILLIMETERS ANGLES $\pm 0.1^\circ$			SIZE	DWG NO	REV
			A3		
$\frac{1}{16}$ OF ANGLE 			FILE NAME: Release Cartridge.dft		
			SCALE:	WEIGHT:	SHEET 2 OF 3

REVISION HISTORY

REV	DESCRIPTION	DATE	APPROVED

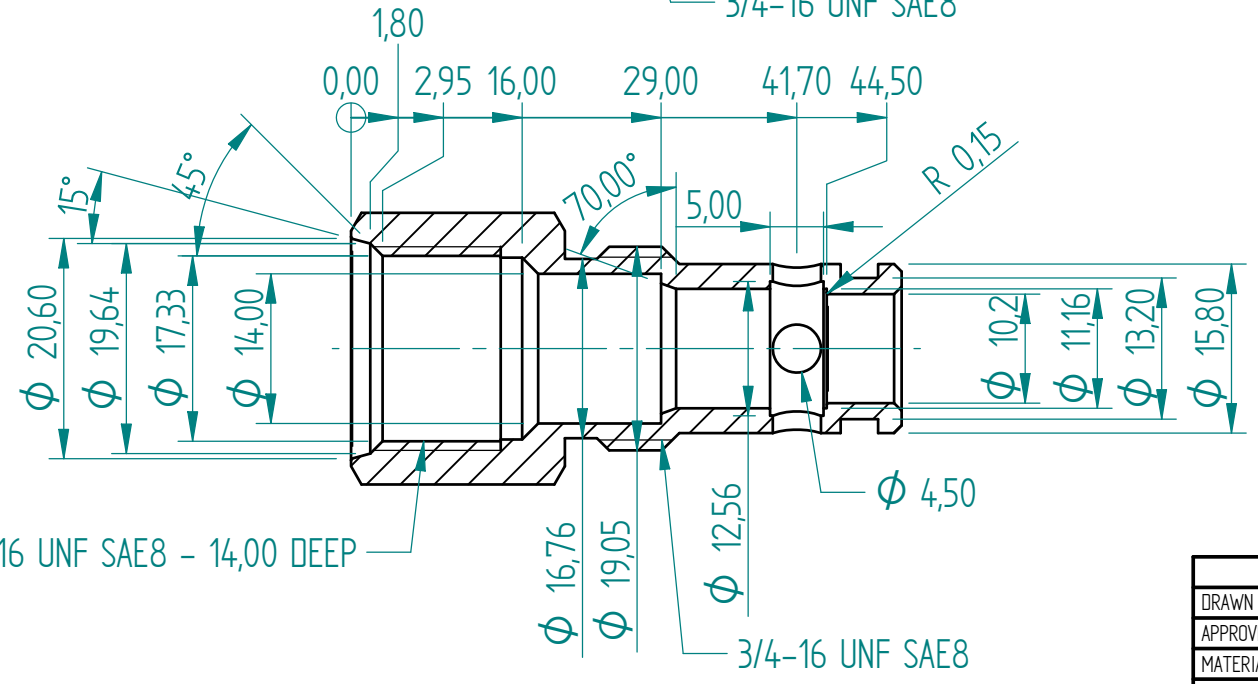
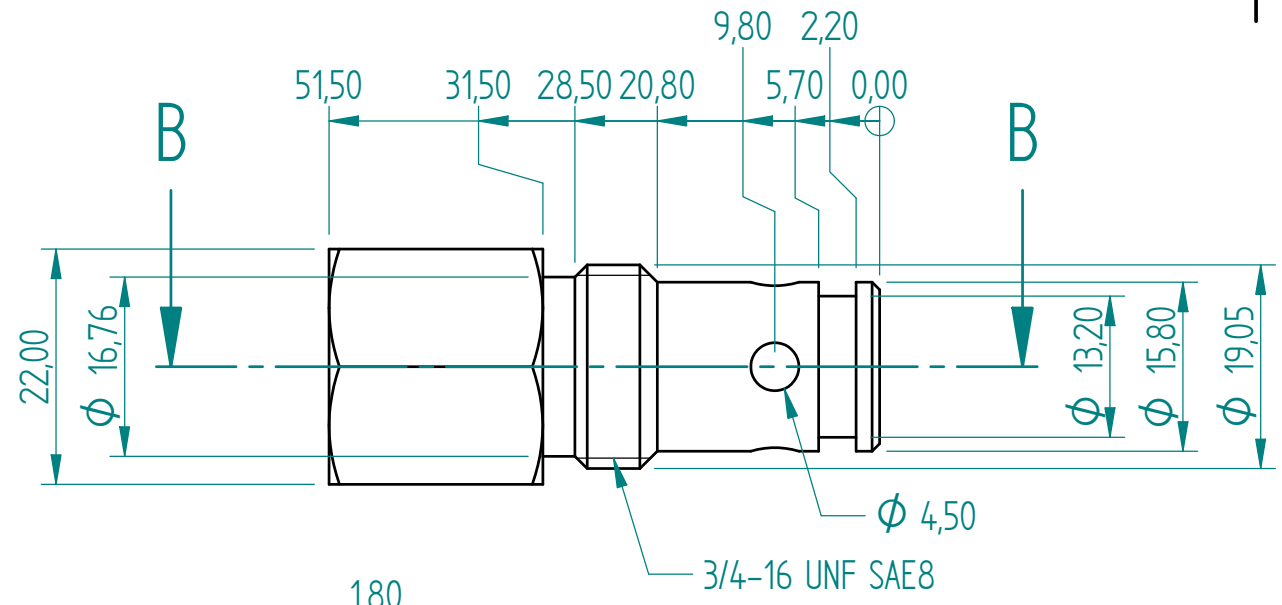

SECTION B-B

	NAME	DATE	PREMAC	
DRAWN	D.L.G.	06/01/10		
APPROVED			TITLE	
MATERIAL			Accumulator Release Cartridge	
TREATMENT			SIZE	DWG NO
UNLESS OTHERWISE SPECIFIED DIMENSIONS ARE IN MILLIMETERS ANGLES $\pm 0.1^\circ$			A3	REV
			FILE NAME: Release Cartridge.dft	
1st ANGLE 			SCALE:	WEIGHT:
2 PL ± 0.02 3 PL ± 0.005			SHEET 3 OF 3	